

Ultra Hawk

Assisted Tube Rolling System



Tube & Pipe Cleaners ◦ Tube Testers ◦ Tube Plugs ◦ Tube Removal ◦ Tube Installation



Operating and Maintenance Instructions

TABLE OF CONTENTS

Introduction	4
Safety Guidelines	5
Receiving & Installation	7
General Information.....	8
Operation Instructions.....	10
Tooling Installation.....	19
Parts List & Diagrams.....	23
Arm & Base.....	23
Control Panel	29
Powerhead.....	36
EPS460 Assembly	40
EPS230 Assembly	42
EPS460 Assembly - Extended Reach Package	45
EPS230 Assembly - Extended Reach Package	47
Maintenance Instructions.....	51
Troubleshooting.....	55
Technical Information	56
Warranty	57

INTRODUCTION

Thank you for purchasing this Elliott product. More than 100 years of experience have been employed in the design and manufacture of this control, representing the highest standard of quality, value and durability. Elliott tools have proven themselves in thousands of hours of trouble-free field operation.

If this is your first Elliott purchase, welcome to our company; our products are our ambassadors. If this is a repeat purchase, you can rest assured that the same value you have received in the past will continue with all of your purchases, now and in the future.

The Ultra Hawk has been designed for the following types of equipment:

Heat Exchangers

Condensers

Chillers

If you have any questions regarding this product, manual or operating instructions, please call Elliott at +1 800 332 0447 toll free (USA only) or +1 937 253 6133, or fax us at +1 937 253 9189 for immediate service.

SAFETY GUIDELINES

Read and save all instructions. Before use, be sure everyone using this machine reads and understands this manual, as well as any labels packaged with or attached to the machine.

WARNING

When using electric tools, certain safety precautions are required to reduce the risk of electrical shock and personal injury.

WARNING

To reduce the risk of injury, always unplug your machine before performing any maintenance. Never disassemble the machine or try to do any wiring on the electrical system. Contact Elliott for all repairs.

- Know Your Elliott Tool. Read this manual carefully to learn your tool's application and limitations as well as the potential hazards specific to this tool.
- Ground Your Elliott Tool. Always use properly grounded electrical outlets, and if using an extension cord, make sure that it is of the proper size for the electrical load and it is equipped with a ground wire and ground plug. Avoid Dangerous Environments. Do not use power tools in damp or wet locations
- Keep Work Area Clean and Well Lit. Cluttered, dark work areas invite accidents.
- Dress Properly. Do not wear loose clothing or jewelry. Wear a protective hair covering to contain long hair. It is recommended that the operator wear safety glasses with side shields or a full face shield eye protection. Gloves and water repellent, nonskid footwear are also recommended. Keep hands and gloves away from moving parts.
- Use Safety Equipment. Everyone in the work area should wear safety goggles or glasses with side shields complying with current safety standards. Wear hearing protection during extended use, respirator for a confined space and a dust mask for dusty operations. Hard hats, face shields, safety shoes, respirators, etc. should be used when specified or necessary. Keep a fire extinguisher nearby.
- Keep Bystanders Away. Bystanders should be kept at a safe distance from the work area to avoid distracting the operator.
- Use The Right Tools. Do not force a tool or attachment to do a job or operate at a speed it was not designed for.
- Use Proper Accessories. Use Elliott accessories only. Be sure accessories are properly installed and maintained.

SAFETY GUIDELINES

- Check for Damaged Parts. Inspect guards and other parts before use. Check for misalignment, binding of moving parts, improper mounting, broken parts or any other conditions that may affect operation. If abnormal noise or vibration occurs, turn the tool off immediately and have the problem corrected before further use. Do not use a damaged tool. Tag damaged tools “Do Not Use” until repaired. A damaged part should be properly repaired or replaced by an Elliott service facility. For all repairs, insist on only identical replacement parts.
- Keep Hands Away from All Moving Parts.
- Do Not Overreach. Maintain Control. Keep proper footing and balance at all times.
- Stay Alert. Watch what you are doing, and use common sense. DO NOT use a tool when you are tired, distracted or under the influence of drugs, alcohol or any medication causing decreased control.
- Unplug Tool. Unplug tool when it is not in use, before changing accessories or performing recommended maintenance.
- Maintain Tool Carefully. Keep tools sharp and clean for best and safest performance. Follow instructions for lubrication, maintenance and changing accessories. For more information see “Maintenance” section. Periodically inspect the tool cord and extension cords for damage. Have damaged parts repaired or replaced by an Elliott service facility.
- Store Idle Tools. When not in use, store your tool in a dry, heated, secured place. For more information see “Maintenance” section.
- Maintain Labels and Nameplates. These carry important information and will assist you in ordering spare and replacement parts. If unreadable or missing, contact an Elliott service facility for a replacement.

RECEIVING & INSTALLATION

Receiving & Uncrating

1. Using a drill/impact w/ T25 bit, remove the crate from around the Ultra Hawk.
2. STOP! – Inspect the machine to ensure the following are included in the crate and/or the machine has not been damaged during shipment. Report all damages or lost items to Elliott Tool Technologies.
 - a.) Power cable
 - b.) Tool package (if ordered with the machine)
 - c.) Any special or added accessories i.e. transformer, adapters or extra consumables.
3. Once uncrated – ensure to contact customers rigging crew to lift and move the Ultra Hawk into the position where utilities and work will be done.
4. Connect air supply connection – $\frac{3}{4}$ " @ 90 PSI, not to drop less than $\frac{1}{2}$ " @ 90 PSI
5. Connect power cable to control panel and then to customer power supply.
6. Ensure the working area around the Ultra Hawk is clean and free of trip hazards. Be sure to place the Ultra Hawk where the floor is level and smooth.
7. Lock the Ultra Hawk down by stepping and locking the floor lock to prevent movement during operation.
8. FLUID CHECK! – take the time to ensure that the fluids are filled and ready for the next step for operation.
9. Switch the main power to 'ON'
 - a.) Also flip switch on side of control box to 'ON' for the screen to turn on and load the UI.
10. Homing the machine after it is powered on. This should be done by an authorized Elliott technician.
11. STOP! – the next step will check the E stops to ensure they it works correctly.
 - a.) While the unit is running, check the E stops to ensure that the system is working as it should in case of an emergency.
 - b.) The E stops should cut power to the linear and rotational drive motors. The PLC and screen will remain on and powered up.

GENERAL INFORMATION

The Ultra Hawk contains two (2) pneumatic controls on the control panel – a Pressure Regulator and an ‘UP/DOWN’ switch.

Pressure Regulator

The Ultra Hawk uses a rodless cable air cylinder to counter balance the weight of the arm and motor mounted to the arm, which travel vertically on the column via a linear bearing system. The arm will be balanced and remain vertically static when the force of the air supply equals the weight of the arm. The arm can then manually be moved and it will remain at this vertical position.

WARNING

WARNING: When adjusting, turn slowly to avoid sudden rise or fall of the arm.

UP/DOWN Switch (Extended Reach Package Only)

Another air cylinder is mounted on the arm itself and is used to raise or lower the outer telescoping arm in order to gain more vertical reach. When the switch is in the ‘DOWN’ position, the cylinder will be relieved of air and the arm will lower into its rested horizontal position. When turned to the ‘UP’ position, the cylinder will fill with air (same air pressure as controlled by the main regulator where the air supply is connected) and extend, causing the outer telescoping arm to rise.

WARNING

WARNING: Stay clear of the arm when the switch is engaged in either direction. The arm rises and falls automatically with extreme force.

GENERAL INFORMATION

The Ultra Hawk contains several components intended for the safety of the operator.

Safety Shut-Off Control Valve

Located at the top of the column on the backside of the cable cylinder. This is a pilot-controlled valve that opens when an air supply of at least 45 psi is supplied to the pilot. When this pressure drops below this the valve shuts and air cannot enter nor escape from the cable cylinder.

Relief Valve

Located at the top of the column on the side of the cable cylinder. This valve relieves the pressure inside the cable cylinder, which is necessary since the cable cylinder is equipped with the safety shut-off control valve which could hold air pressure inside the cylinder. It is important to use this relief valve prior to maintenance of any of the pneumatic components, especially the cable cylinder, or storing the machine for extended periods of time.

Arm Locking Mechanism

Located on the arm rest. This is a spring plunger that prevents the arm from rising out of the arm rest in the event the pressure regulator dial on the control is inadvertently turned. This should be engaged at all times when the arm is in the arm rest.

Check Valve

Located at the underside of the control panel. In the event that the air supply is suddenly removed the check valve will allow the system to maintain its current pressure.

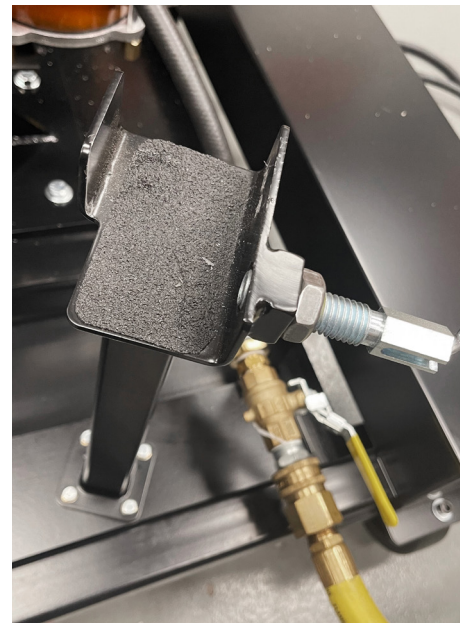
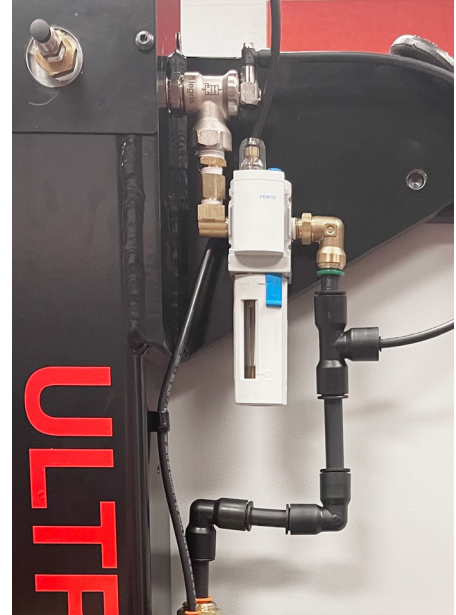

! WARNING

WARNING: If the arm is manually moved or the controls on the control panel are adjusted prior to the air supply being re-connected the system will lose its pressure and the arm may fall rapidly.

Flow Control Valves (Extended Arm Packaged Only)

Located on the ports of the tie rod air cylinder. These valves control the rate of rise or fall of the telescoping arm by controlling the air flow during exhaust. The rate of rise is controlled by the flow control valve located on the outer-most end of the cylinder closest to the piston rod (with the muffler attached). The rate of fall is controlled by the flow control valve located on the inner-most end of the cylinder (with the air line attached).

OPERATION INSTRUCTIONS

Engage the floor lock located on the base at all times when the machine is not being transported.

Prior to each use of the machine, please review and complete the “Before Each Use” maintenance steps located in the Maintenance Section.

Prior to connecting the main air supply, ensure the following:

1. The arm locking mechanism on the machine’s push handle is engaged.
2. The regulator on the front control panel is rotated fully in the counter-clockwise direction to its ‘OFF’ position.
3. The ‘UP/DOWN’ switch is in the ‘DOWN’ position. **(Extended Reach Package Only)**
4. The valve at the main air supply inlet is off (the handle is turned to the horizontal position 90° to the line).

Supply air to the system by opening the valve at the main air supply inlet. To do this, rotate the handle to its open position, parallel to the line and away from the air inlet.

Disengage the arm locking mechanism by retracting the ‘L’ handle and turning, locking it open.

To raise the arm out of the arm rest, SLOWLY turn the pressure regulator dial on the control panel clockwise until the arm starts to rise. Once the arm is just above and is clear of the arm rest stop turning the dial to hold the arm’s position. If the arm continues to rise SLOWLY turn the dial slightly in the counter-clockwise direction until the arm stops and maintains its position. The arm can now be manually moved into its desired vertical position.

To lower the arm via the dial on the control panel, turn the dial SLOWLY in the counter-clockwise direction until the arm starts to lower.

NOTE: If the dial is turned too quickly while lowering the arm, the arm may stop and maintain its position. This is because the safety shut-off valve has engaged before all of the air could bleed from the cable cylinder and back through the pressure regulator on the control panel. To re-engage it and continue to lower the arm, turn the dial slowly in the clockwise direction to slightly raise the arm then repeat the process to lower.

OPERATION INSTRUCTIONS

After each time you use the Ultra Hawk it is important to lower the arm into the arm rest and relieve the air from the system, especially prior to storing and transporting. To set the arm and relieve the air from the system:

1. Turn the 'UP/DOWN' switch on the control panel to the 'DOWN' position to lower the outer telescoping arm to its rested horizontal position. **(Extended Reach Package Only)**
2. Lower the arm MANUALLY into the arm rest.
3. Engage the locking mechanism on the arm rest.
4. Slowly rotate the regulator dial on the control panel in the counter-clockwise direction to its 'OFF' position.
5. Disengage the safety lockout at the main air supply inlet by sliding the red slide lock mechanism down.
6. Disconnect the air supply.
7. If it is to be stored for long periods of time, relieve the air pressure from the cable cylinder by pressing in the relief valve located at the top of the column for approximately 1 second (this is just enough to relieve most of the pressure but not all of it. If all of the pressure is relieved the cable could come off of the pulley at the top of the cable cylinder). If repairs are to be performed, see the 'Repair' section.

Extended Reach Package

If additional vertical reach is required, the outer arm has the ability to extend upward. To do so, turn the 'UP/DOWN' switch on the control panel to the 'UP' position. To lower the arm, turn the switch to the 'DOWN' position. It may take several seconds for the arm to react after the switch is turned, as the air needs to bleed from the lines from the cylinder back to the switch.

The rate of rise is controlled by the flow control valve located on the outer-most end of the cylinder closest to the piston rod (with the muffler attached). The rate of fall is controlled by the flow control valve located on the inner-most end of the cylinder (with the air line attached).

OPERATION INSTRUCTIONS

Power Head

There are 2 buttons on the rear vertical grip of the power head. Pressing the green switch turns the motor on. Pressing it a second time will advance the expander into the tube to roll to a desired torque setting. Once the target torque is reached, the motor will automatically stop and reverse to the home position. By pressing the green button again, the process is repeated.

Located under the green button is a yellow button. This will override the advancement to stop the cycle and move the powerhead in reverse. This can be used to interrupt the cycle. If you push the yellow button on the operator handle, the Ultra Hawk will stop the rolling procedure and reverse back to its 'Tool Home' position. NOTE: You will not need to clear a HMI alert unless the tool has reached max travel or if it has not reached the programmed torque amount.

A E-stop button is also located at the operator handle location. If this is pushed this will stop the process of rolling or advancing. Once it is decompressed, the operator will need to clear an alert at the HMI and tell the tool to return to the 'Tool Home' position.

 **WARNING**

If the Operator E-Stop is pressed, and you are confirming that the expander and power head are being sent to the 'Tool Home' position, KEEP HANDS CLEAR OF THE POWER HEAD.

NOTE: During this E-Stop engagement, operating and control is prohibited at the operator's position. The HMI and PLC will remain powered on and running.

Control Panel

Along the side of the control panel is an emergency stop button. When pressing this E-Stop the machine will stop any and all functions of the rolling process. The motor will not work in forward or reverse, the control panel screen will stay powered on. To restart the system, disengage the E-stop, clear the HMI alarm, and resume rolling by pressing the green button on the operator handle.



OPERATION INSTRUCTIONS

HMI / User Interface

Starting A New Job

1. To start a job from the 'Home Screen', you will need to start by selecting the 'Mode'. When pressed it will ask you "do you want to change the installed tool", select 'Yes'

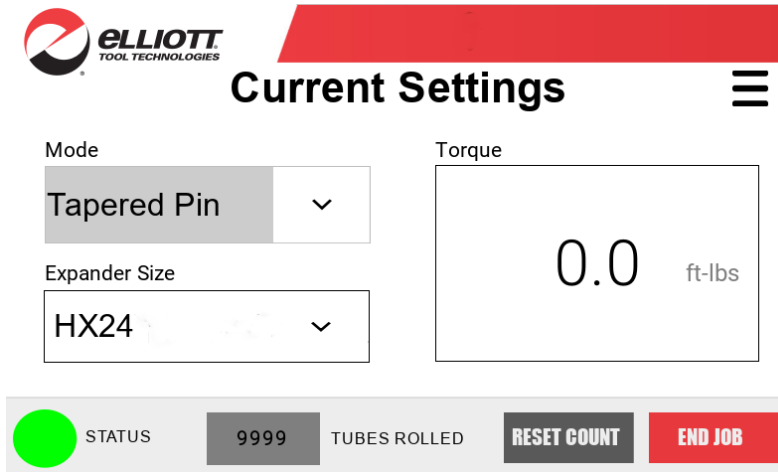

2. After pressing 'Yes' the HMI will launch you into series of questions about the tool and mode in which you will use for this job. Follow the instructions on the screen and use caution and keep hands away from moving parts.
3. After the tool and mode is selected. You will proceed to roll a tube to find the desired wall reduction needed for the application. Once this is torque setting is final. Press the reset count. Then press the 'Jobs' button.
4. At the 'Jobs' Screen you will type a job number into box. After that is selected, press 'Save Current Settings'. If you have selected a Job # that is already taken it will prompt you if you want to overwrite a custom job in this slot. Select 'Yes' or 'No'

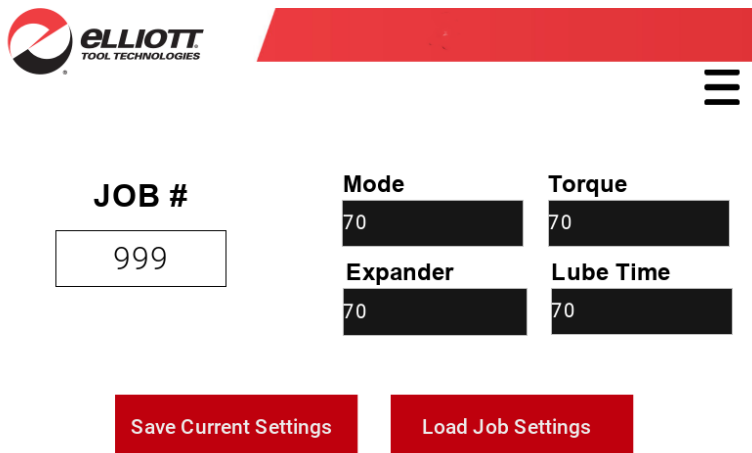

OPERATION INSTRUCTIONS



5. After you select the job and save it, you can use that job in the future. You can now press the 'Elliott Tool Technologies' Logo to take you to the home screen. This will still have the job setting you were working on.

Loading A Job

1. To start a job that you already have saved, press the 'Jobs' button.
2. Find the job by typing in the 'Job #' search box. As you type the job number the vales will auto fill to the right.
3. Once the correct job is found. Press 'Load Job Settings', they will now be displayed on the Home Screen.
4. Press the Elliott Tool Technologies logo to be taken back to the home screen with those settings now loaded.

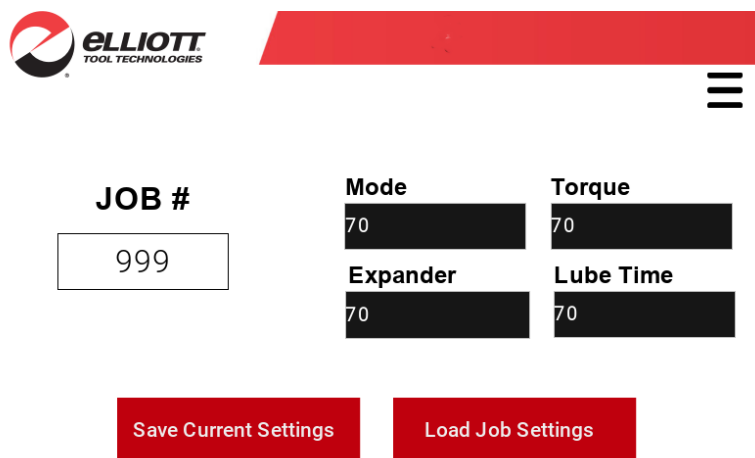

5. BE SURE TO INSTALL THE CORRECT EXPANDER AND CHECK THE MODE AND EXPANDER SIZE PRIOR TO STARTING THE JOB.

OPERATION INSTRUCTIONS

Exporting A Job

1. When finished with a job, press 'End Job'
2. A prompt will ask you "Do you want to end the current job and open the data export page?" Select yes.
3. From this page you can name the file name and job ID
4. Be sure to have your USB plugged into the side of the control panel. It will take a few seconds for the system to read the USB.

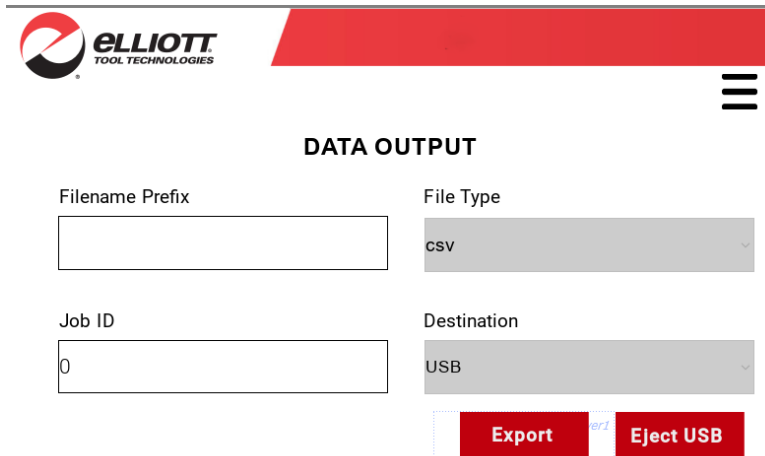

The image shows a web interface for 'DATA OUTPUT'. At the top left is the Elliott Tool Technologies logo. To its right is a red horizontal bar. On the far right of this bar is a hamburger menu icon (three horizontal lines). Below the bar, the text 'DATA OUTPUT' is centered. There are four input fields arranged in a 2x2 grid: 'Filename Prefix' (empty text box), 'File Type' (dropdown menu showing 'csv'), 'Job ID' (text box containing '0'), and 'Destination' (dropdown menu showing 'USB'). At the bottom, there are two red buttons: 'Export' and 'Eject USB'.

OPERATION INSTRUCTIONS

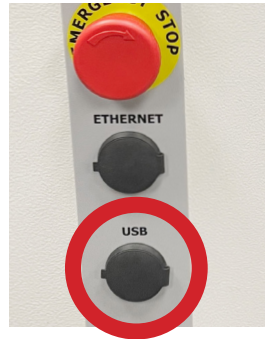

5. Once the USB has been recognized, the Export button will brighten.
6. When you press 'Export', the HMI will give you a prompt when it has successfully exported the data. Hit 'OK', and select 'Eject USB' on the screen.

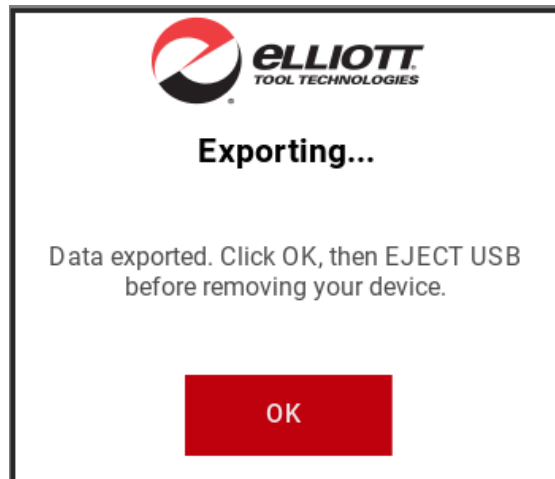

OPERATION INSTRUCTIONS

Auto-Lubrication

There are two pressure regulators on the lube tank which independently control the flow of the lube and air. This particular system will only use pressurized lube.

The lube system has two switches which need to be turned on in order to function properly. The first is the electrical switch located on the side of the electrical panel. The second is the air control valve located on the side of the Ultra Hawk air control panel.

WARNING

TURN OFF LUBE AIR SUPPLY PRIOR TO FILLING RESERVOIR OR SERVICING SYSTEM.

NOTE: The lube tank uses pressurized air (To Not Exceed 30 PSI) to force out lubricant to the expander. The tank filler cap should only be removed when the tank is de-pressurized. To do this, turn the air control valve on the side of the Ultra Hawk control panel to 'OFF'. You will hear air pass through the valve – this is normal. If there is still a small amount of pressurized air trapped in the tank once the valve is turned off, there is a relief hole in the thread of the filler cap. Once the cap is removed approx half-way, the trapped air will vent through this hole prior to its removal. The lubricator can accommodate a wide variety of lubricants including those with viscosities up to the equivalent of 10W oil. Elliott recommends the P8395 or P8784 series water or petroleum based lubricants for use with the system.

Once the motor starts in the forward/expanding direction the lube on-delay will start. This on-delay is a pre-set time of .2 sec programmed into the HMI in the electrical panel. The lubricant will then start flowing. The time delay relay controls the length of time that the lube flows. The timer will restart once the motor is again started in the forward/expanding direction. This can be adjusted based on individual needs. This is done on the HMI to the preferred setting.

Upon initial start-up or after an expander/mandrel change the system may need primed. Press and hold the "LUBE PRIME" button. Flow adjustments are inside the HMI of the Ultra Hawk. This will give you adjustments from .2 - .5 seconds



OPERATION INSTRUCTIONS

Auto-Lube Time can be adjusted under the “Settings” menu.

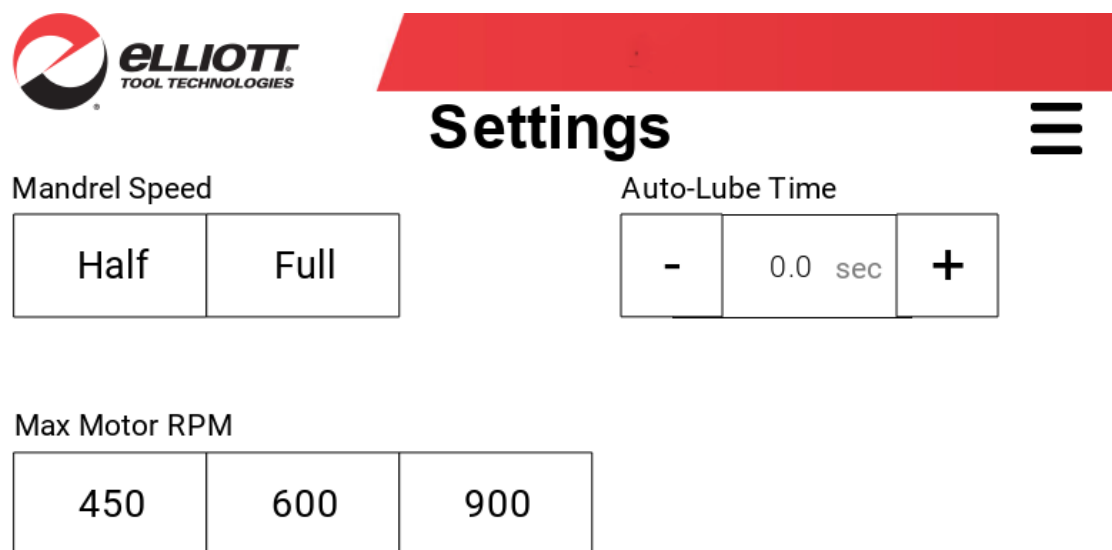
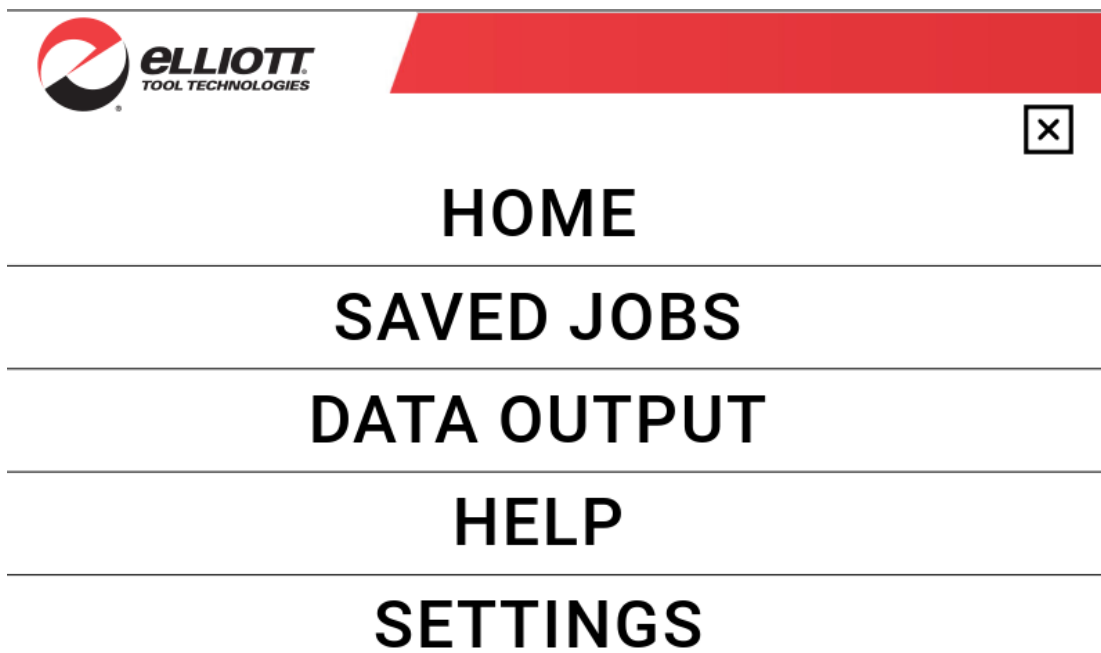

TOOLING INSTALLATION

Start-Up

1. Pick the tool that you want to conduct the first expansion with.
2. On the control panel screen, the HMI will walk you through a series of prompts to ensure that the tool you need to use is properly selected and installed in the machine prior to a new job/vessel being started.
3. After the above step is completed, the powerhead will be moved into its home position for the tool size and the expander will be installed into the machine.
4. Loading the expander into the power head.
 - a.) The front of the power head has a black retention expander holder. Rotate lever to the unlock position. Insert Expander into the tooling interface ensuring that the cage adapter slot is aligned with the drive pin. Once fully inserted, rotate lever to the locked position.
 - b.) Draw mandrel back toward the hex chuck, slide sleeve backwards and insert the mandrel into place. Check to be sure it's secure.
 - c.) Ensure the proper orientation of the lube adapter. The rubber O-ring should be placed on the mandrel where it's closest to the mandrel hex. The wrong orientation can result in the expander not being able to be loaded into the quick change chuck.
5. Once tool is installed into the power head, the lube system needs to be primed so it's ready for operation. Using the Auto Lube Prime function, press and hold the lube prime button until lubricant comes out from the tool. Release after you see lubricant flowing. Be sure to clean any spilled lubricant off the floor and the power head.

TOOLING INSTALLATION

Changing Tools & Jobs

1. If the expander is showing signs of wear, you should switch it out before it reaches the point of failure. This process is a normal tool change, so **there is no need to select anything on the control panel.**
 - a.) In the event you need to change the size or style of the tool in use after setting up a job, simply select the expander or mode options on the control screen to initiate the tool change protocol. The HMI will walk you through the set-up process to ensure the powerhead is in the proper mode and start position.

CAUTION

DO NOT change tool size or rolling mode mid job without telling the control screen and following the steps. This can result in tooling failure and under or over rolled tubes.



**Send Tool Home,
then Remove Tool**

Send Tool Home

Cancel

TOOLING INSTALLATION



ELLIOTT
TOOL TECHNOLOGIES

Choose Mode

MODE

TAPERED PIN

OK

Cancel



ELLIOTT
TOOL TECHNOLOGIES

Choose Tool

HX24*0

OK

Cancel

Back to Modes

TOOLING INSTALLATION



Install Tool

HX24*

Move To New Home

Cancel

Back to Tools

2. Once you have finished a job, push “End Job” on the lower right-hand corner of the control screen. This will stop tracking your expansion count and will take you to the data output screen. From here you can export the data logged from your last job to a USB if plugged into the side of the panel.
3. Once a new tool has been installed on the powerhead, prime the auto-lube system.

PARTS LISTS & DIAGRAMS

Arm & Base

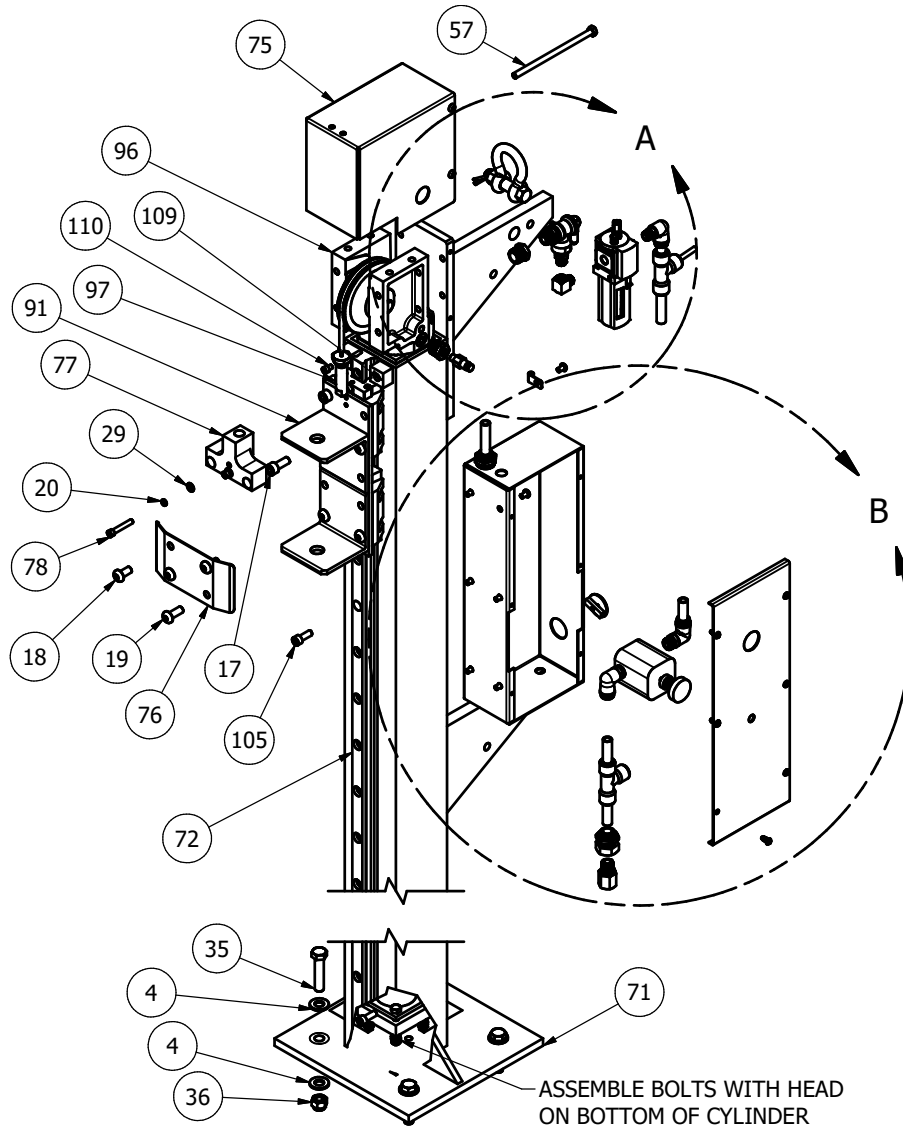

PARTS LISTS & DIAGRAMS

Arm & Base

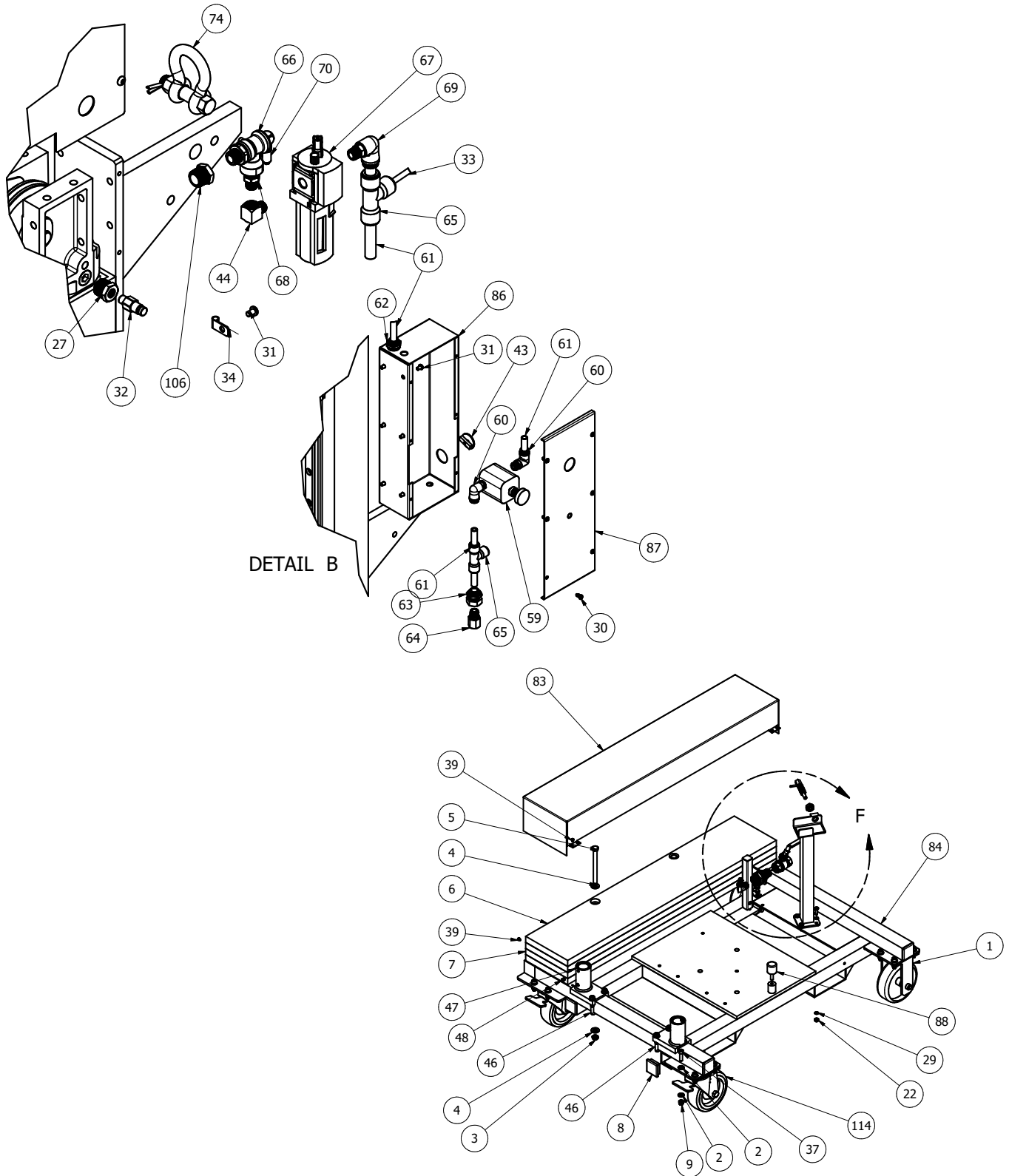

PARTS LISTS & DIAGRAMS

Arm & Base

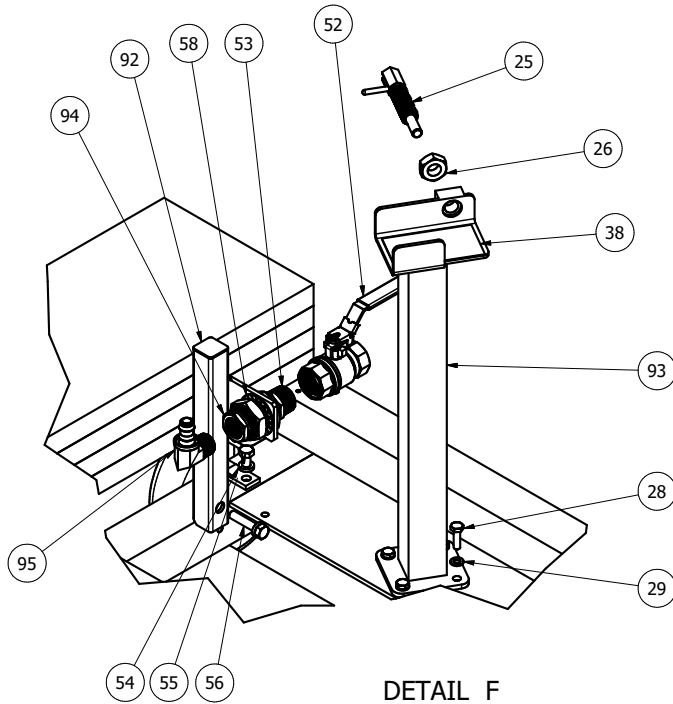

DETAIL F

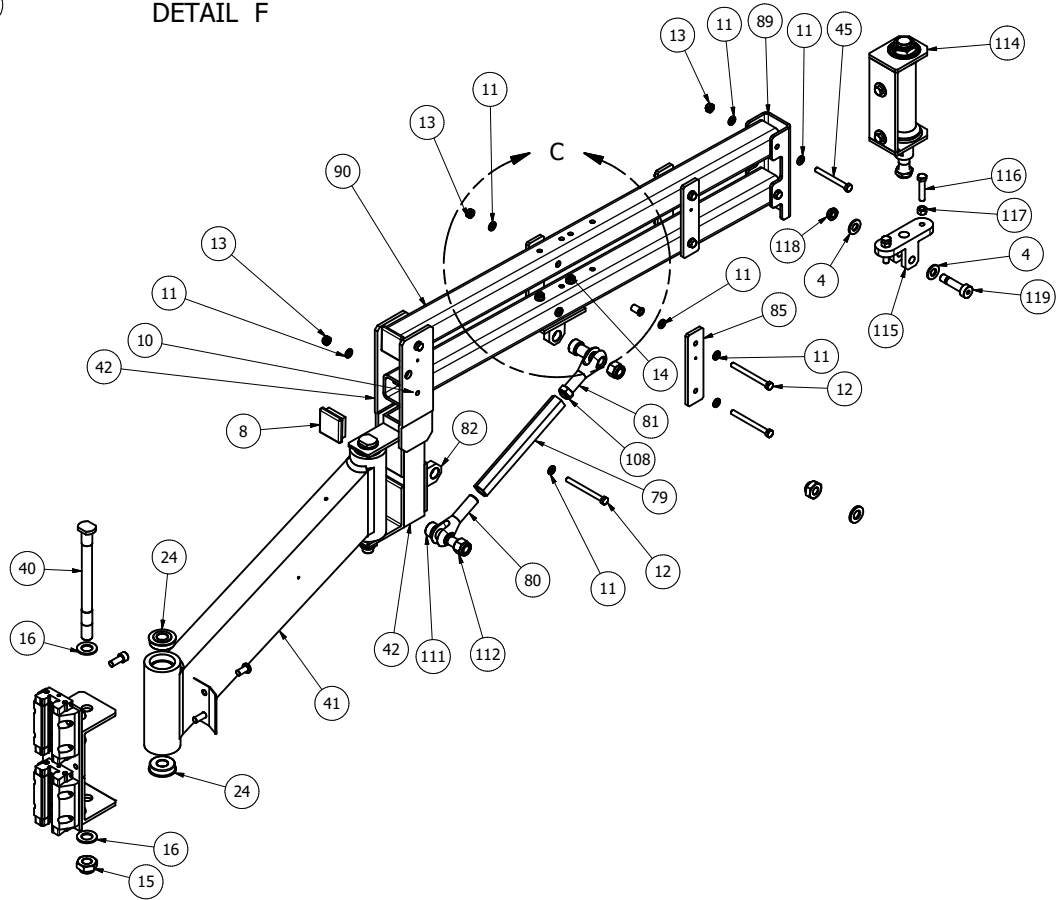

PARTS LISTS & DIAGRAMS

Arm & Base

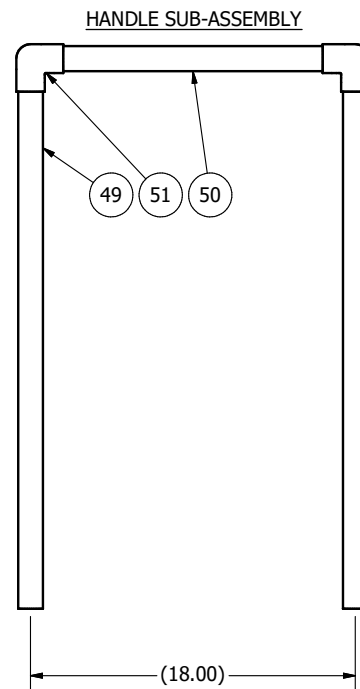
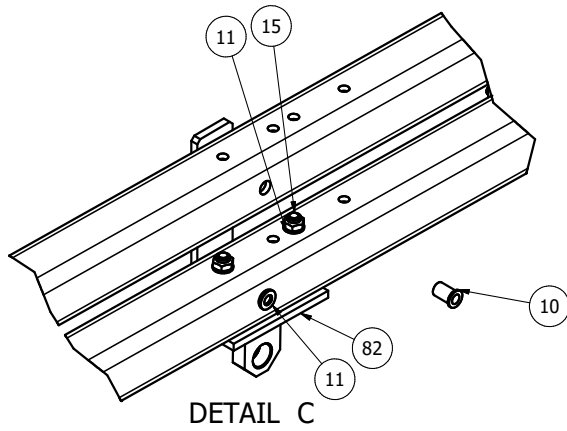

PARTS LISTS & DIAGRAMS

Arm & Base

PARTS LIST				PARTS LIST			
ITEM	QTY	PART NUMBER	DESCRIPTION	ITEM	QTY	PART NUMBER	DESCRIPTION
1	2	ETR1002	RIGID CASTER	35	4	130EK	HEX HEAD CAP SCREW, 1/2-13 X 2-1/4
2	32	132C	WASHER, 3/8, SAE	36	4	546X	ELASTIC LOCKNUT, 1/2-13
3	2	546N	ELASTIC LOCKNUT, 1/2-13	37	16	P8302-94	SOCKET HEAD CAP SCREW, 3/8-16 X 1-1/4
4	14	132G	WASHER, 1/2 USS	38	3.5"	41-6243T721	ANTISLIP TAPE
5	2	130EV	HEX HEAD CAP SCREW, 1/2-13 X 5-1/2	39	8	P8597-7	BUTTON HEAD CAP SCREW, #10-32 X 1/4
6	1	ETR1005	TOP WEIGHT PLATE	40	2	ETR3013P	PIN
7	3	ETR1006	WEIGHT PLATE	41	1	ETR3004P	INNER ARM
8	8	ETR1008	PLUG	42	1	ETR3005P	ARM LINK
9	16	546V	ELASTIC LOCKNUT, 3/8-16	43	2	41-71995K82	HOLE PLUG
10	16	41-6338K454	BRONZE SLEEVE BEARING	44	1	41-50785K43	PIPE FITTING, HIGH PRESSURE, 1/4 FEMALE TO MALE, 90°
11	32	132B	WASHER, 5/16	45	2	130BN	HEX HEAD CAP SCREW, 5/16-18 X 3
12	6	130BQ	HEX HEAD CAP SCREW, 5/16-18 X 3-1/2	46	2	ETR1018	SQUARE U-BOLT
13	16	546C	ELASTIC LOCKNUT, 5/16-18	47	2	ETR1019	FLANGE
14	2	130BM	HEX HEAD CAP SCREW, 5/16-18 X 2-3/4	48	4	128FQK	CUP POINT SET SCREW, 3/8-16 X 3/8
15	2	546B	ELASTIC LOCKNUT, 3/4-10	49	2	ETR1020	HANDLE POST
16	4	132K	WASHER, 3/4	50	1	ETR1021	HANDLE GRIP
17	2	P8302-131	SOCKET HEAD CAP SCREW, M10 X 25	51	2	ETR1022	ELBOW FITTING
18	2	P8597-63	BUTTON HEAD CAP SCREW, M10 X 20	52	1	41-4628K84	BALL VALVE
19	6	P8597-64	BUTTON HEAD CAP SCREW, M10 X 25	53	1	41-5485K25	HEX NIPPLE, 3/4
20	2	133N	LOCK WASHER, 1/4	54	2	133A	LOCK WASHER, 5/16
21	4	41-90309A537	SPACER (NOT SHOWN)	55	1	163BE	HEX HEAD CAP SCREW, 5/16-24 X 5/8
22	4	546D	ELASTIC LOCKNUT, 1/4-20	56	1	163BK	HEX HEAD CAP SCREW, 5/16-24 X 1-1/2
23	2	130BD	HEX HEAD CAP SCREW, 5/16-18 X 7/8 (NOT SHOWN)	57	4	130BY	HEX HEAD CAP SCREW, 5/16-18 X 6
24	4	41-6384K369	BEARING	58	1	41-50785K735	BULKHEAD FITTING, 3/4
25	1	41-3403A18	SPRING PLUNGER	59	1	PTR211	REGULATOR
26	1	170G	HEX JAM NUT, 5/8-11	60	2	41-51025K146	PUSH TO CONNECT ELBOW FITTING, 3/8 X 1/2 TUBE
27	1	41-4429K421	ADAPTER, 1/2 X 1/8 NPT	61	50"	41-5156K89	1/2" TUBING
28	4	130AD	HEX HEAD CAP SCREW, 1/4-20 X 7/8	62	1	41-5111K15	THROUGH-WALL COUPLING, 1/2" TUBE
29	10	132A	WASHER, 1/4	63	1	41-5111K207	THROUGH-WALL COUPLING, 1/2" TUBE
30	6	577-4	THREAD-CUTTING SCREW, #10-32	64	1	41-9171K831	STRAIGHT ADAPTER, 3/8 NPT
31	11	P8597-15	BUTTON HEAD CAP SCREW, 1/4-20 X 3/8	65	2	41-5779K673	PUSH-TO-CONNECT TEE FITTING, 1/2" X 1/4" TUBE
32	1	ETR5009	RELIEF VALVE	66	1	41-62395K63	SAFETY SHUT-OFF CONTROL VALVE
33	72"	41-5156K87	1/4" TUBING	67	1	PTR210	LUBRICATOR
34	1	41-8863T12	1/4" CABLE CLIP	68	1	41-5485K32	STRAIGHT REDUCER, 3/8 X 1/4 NPT MALE

PARTS LISTS & DIAGRAMS

Arm & Base

PARTS LIST				PARTS LIST			
ITEM	QTY	PART NUMBER	DESCRIPTION	ITEM	QTY	PART NUMBER	DESCRIPTION
69	1	41-51025K145	PUSH-TO-CONNECT ELBOW ADAPTER, 1/2" TUBE X 1/4 NPT	101	4	ETR7006	HAND CRUSH LABEL (NOT SHOWN)
70	1	41-5779K659	PUSH-TO-CONNECT ELBOW, 1/4 TUBE X 10-32	102	1	P8161S	CAPLUG (NOT SHOWN)
71	1	EPS2001P-H	COLUMN	103	1	EPS7003	SERIAL NUMBER LABEL (NOT SHOWN)
72	1	EPS2005	RAIL	104	4	41-3088A384	SHIM (NOT SHOWN)
73	1	EPS7002	PRODUCT LABEL (NOT SHOWN)	105	20	P8302-217	SOCKET HEAD CAP SCREW, 1/2 X 3/8
74	1	EPS2008A	HOIST RING	106	1	41-4429K413	REDUCER BUSHING, 1/2 X 3/8
75	1	EPS2003P	CYLINDER COVER	107	1	ETR7002	PRODUCT LABEL (NOT SHOWN)
76	1	EPS3015P	SWING PLATE	108	1	170HH	HEX JAM NUT, 3/4-16
77	1	EPS3001	HANGER	109	2	41-9306K821	UNTHREADED BUMPER
78	2	P8302-77	SOCKET HEAD CAP SCREW, 1/4-20 X 1-1/2	110	2	P8302-187	SOCKET HEAD CAP SCREW, 1/4-20 X 5/16
79	1	EPS3017	CONNECTING ROD	111	2	539A	SHOULDER SCREW, 3/4 X 1-1/4
80	1	EPS3016L	CLEVIS ROD END	112	2	546CC	ELASTIC LOCKNUT, 5/8-11
81	1	EPS3016R	CLEVIS ROD END	113	2	PX310	SWIVEL CASTER
82	2	EPS3009P	PIVOT BRACKET	114	1	PTR156	SWIVEL MOUNT
83	1	EPS1007P	WEIGHT COVER	115	1	PX154P	LEVELING MOUNT
84	1	EPS1001P	BASE	116	2	163CL	HEX HEAD CAP SCREW, 3/8-24 X 1-3/4
85	4	EPS3012P	SUPPORT BRACKET	117	2	171Q	HEX NUT, 3/8-24
86	1	EPS2009P	CONTROL BOX	118	1	546XY	ELASTIC LOCKNUT, 1/2-13
87	1	EPS2010P	CONTROL BOX COVER	119	1	5390	SHOULDER SCREW, 1/2-13 X 1-1/2
88	1	EPS1009	BUMPER				
89	1	EPS3020P	MOTOR MOUNT BRACKET				
90	2	ETR3019P	OUTER ARM				
91	1	EPS3002	ARM HANGER ASSEMBLY				
92	1	EPS1130	AIR SUPPLY BRACKET				
93	1	EPS1013P	ARM REST				
94	1	41-149IN206	3/4" NPT X 1/2" NPT REDUCER				
95	1	41-91465K66	PUSH ON HOSE BARB, 1/2 NPT X 1/2 HOSE				
96	1	EPS2002P	CABLE CYLINDER				
97	2	EPS2006	CARRIAGE				
98	1	ETTLBL07500A	ELLIOTT LOGO LABEL (NOT SHOWN)				
99	1	ETR7004	ADJUST REGULATOR LABEL (NOT SHOWN)				
100	1	ETR7005	TRANSPORTING CAUTION LABEL (NOT SHOWN)				

PARTS LISTS & DIAGRAMS

Control Panel

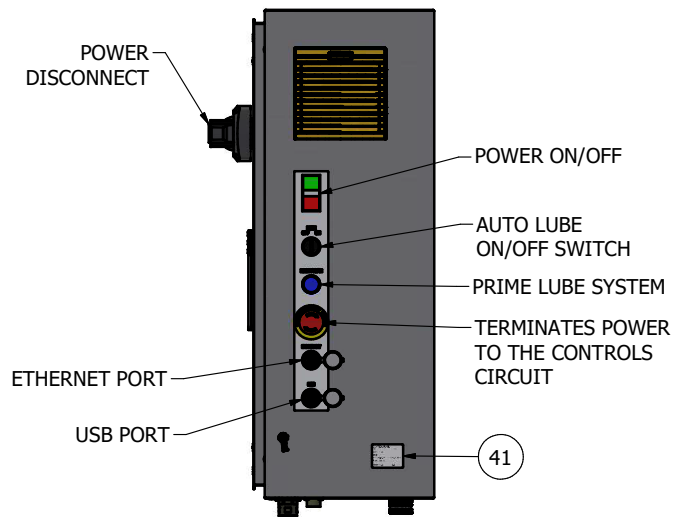
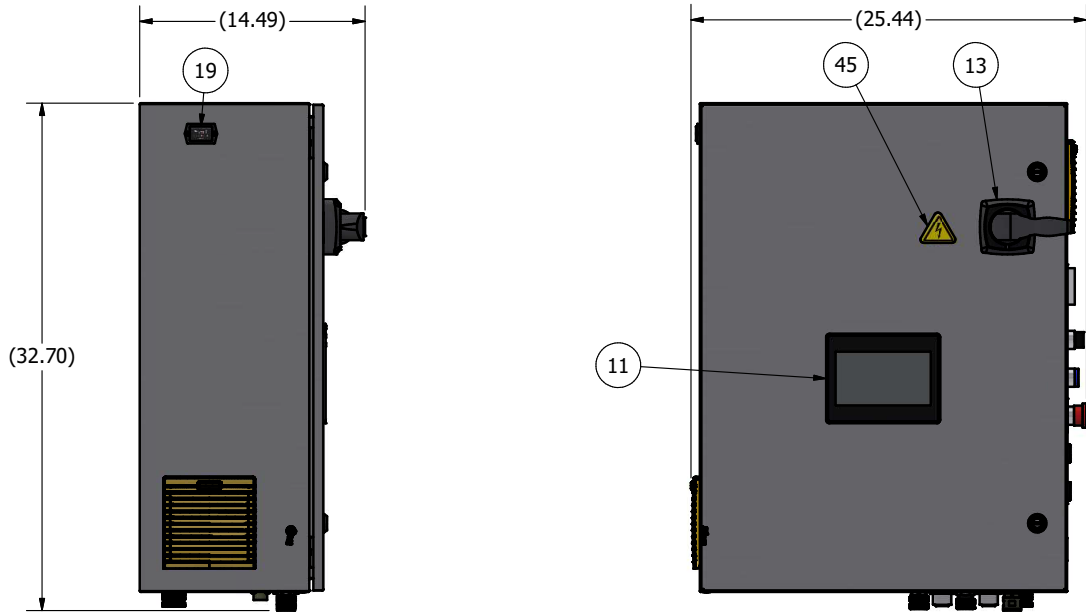

PARTS LISTS & DIAGRAMS

Control Panel

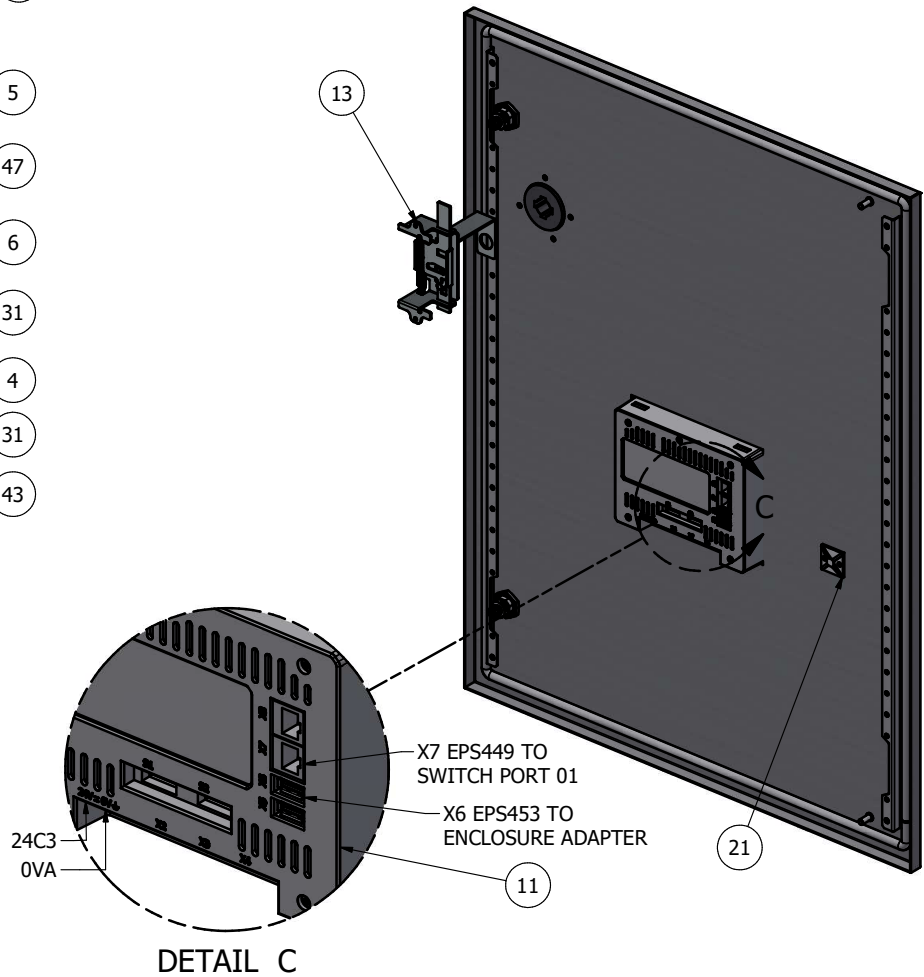
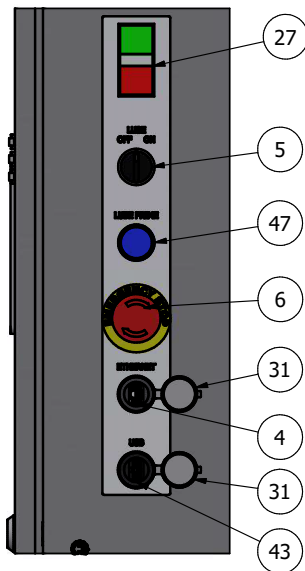
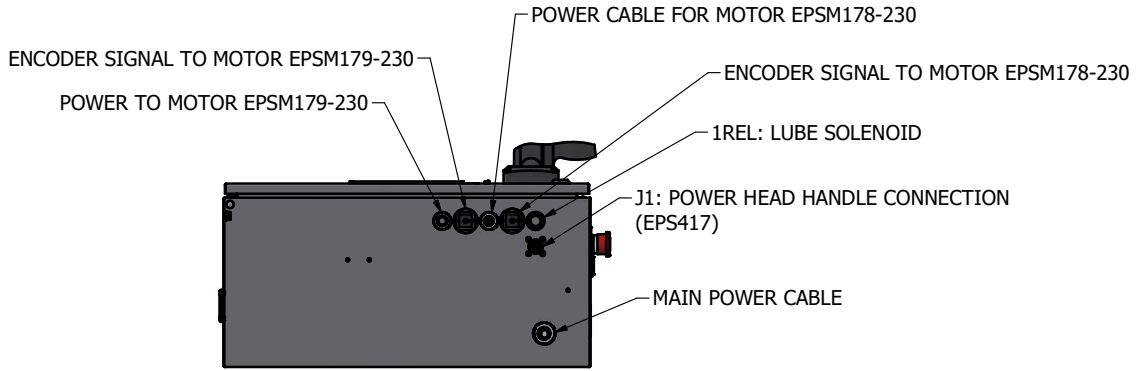

PARTS LISTS & DIAGRAMS

Control Panel

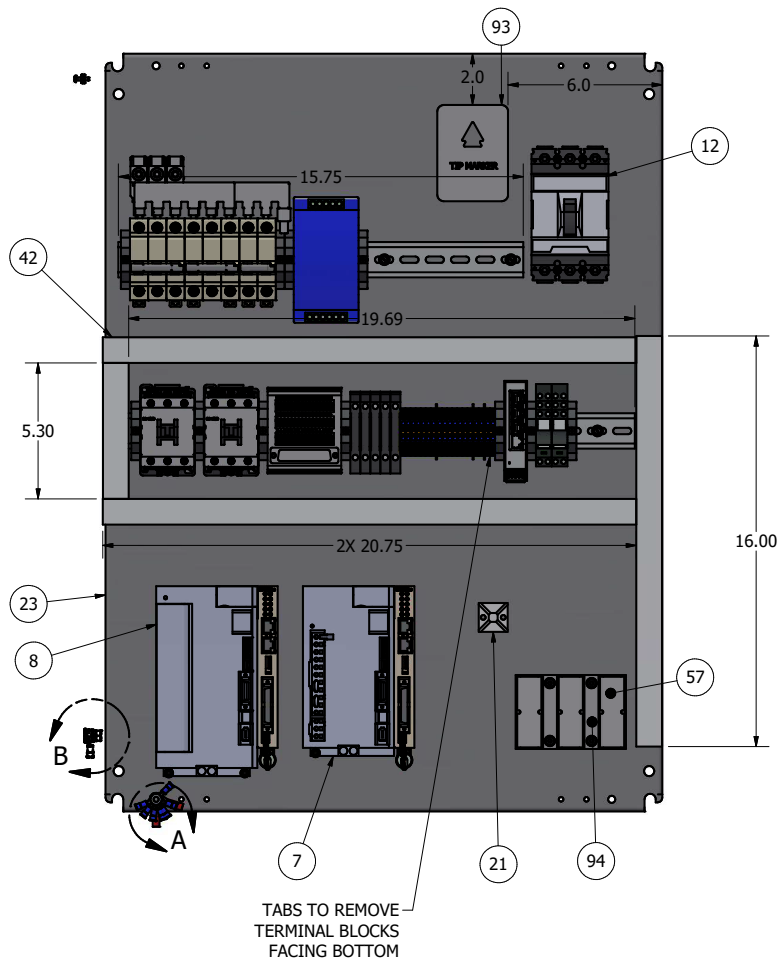
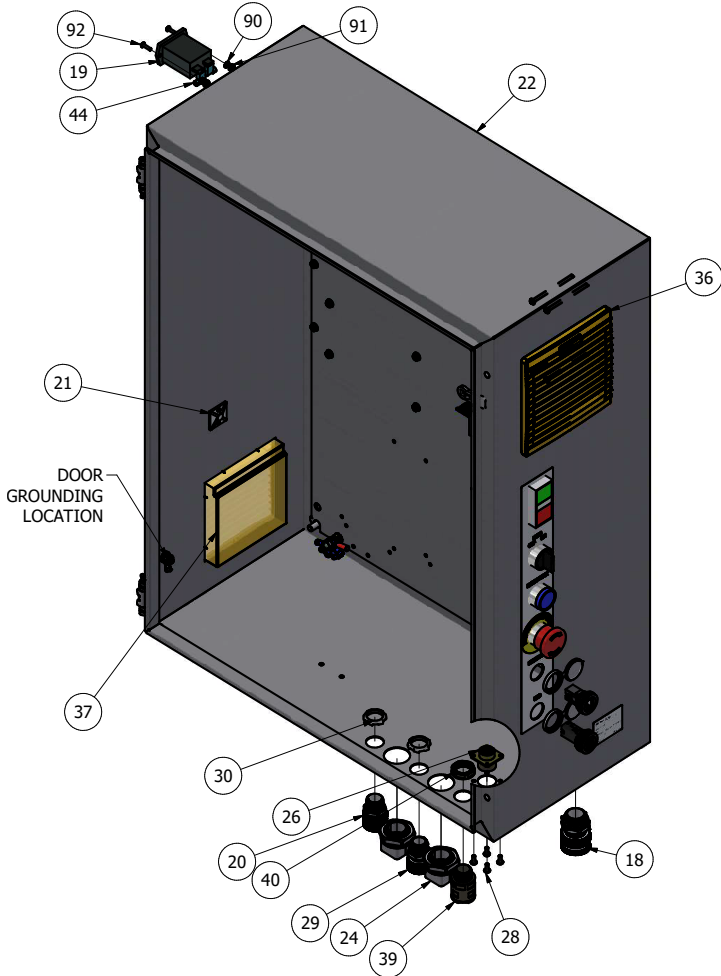

PARTS LISTS & DIAGRAMS

Control Panel

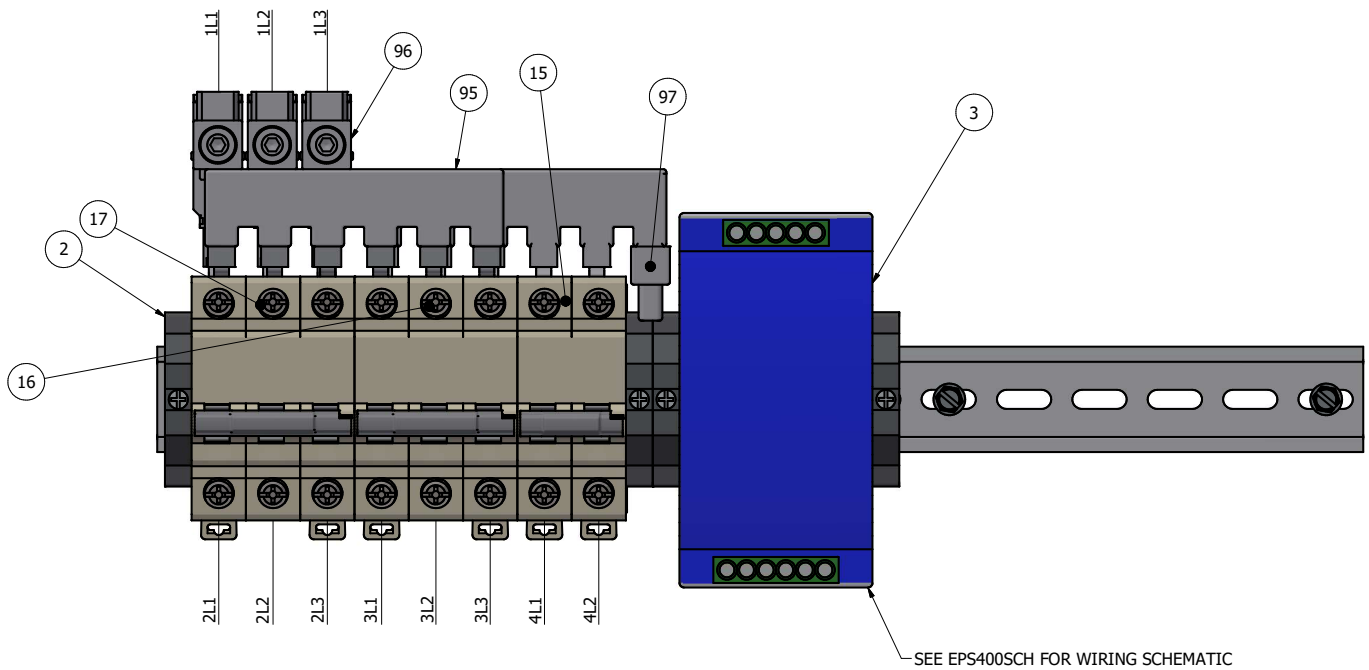
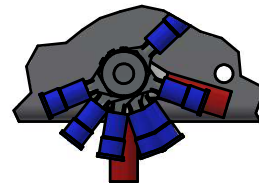
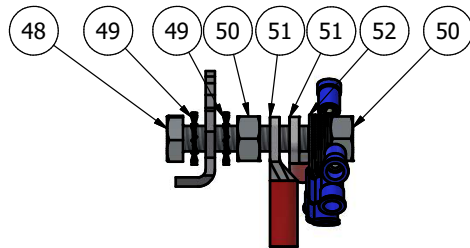

PARTS LISTS & DIAGRAMS

Control Panel

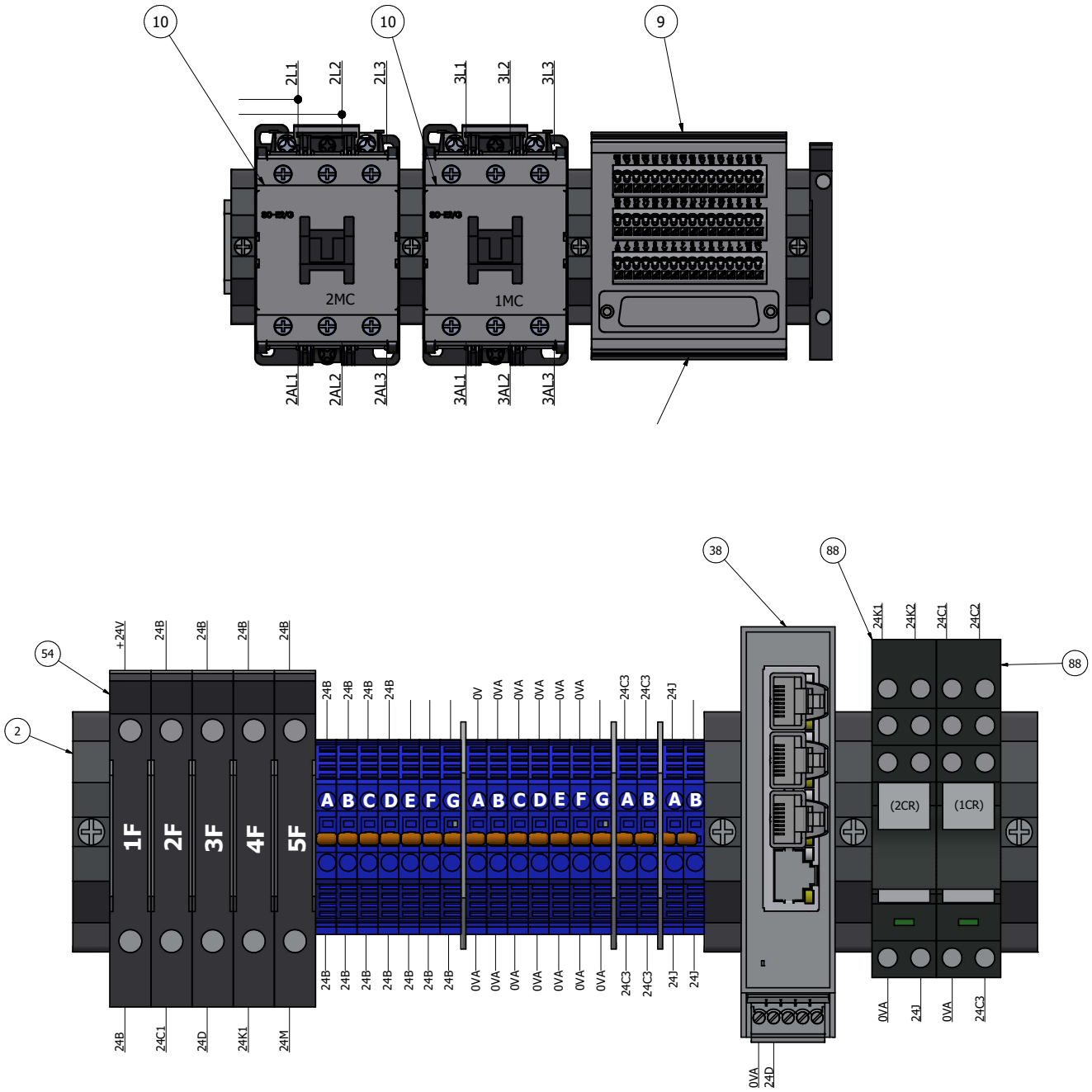

PARTS LISTS & DIAGRAMS

Control Panel

PARTS LIST				PARTS LIST			
ITEM	QTY	PART NUMBER	DESCRIPTION	ITEM	QTY	PART NUMBER	DESCRIPTION
67	25	06331-7	BLACK ELECTRIC WIRE, 12 AWG	34	1	EPS445	DIN RAIL, 40CM
68	72	04131-7	BLACK ELECTRIC WIRE, 8 AWG	35	3	EPS434	POWER DISTRIBUTION BLOCK COVER
69	78	M5801-01-2188	RED ELECTRIC WIRE, 16 AWG	36	1	EPS450	COOLING FAN
70	25	07131-6	RED ELECTRIC WIRE, 14 AWG	37	1	EPS451	FILTERED VENT
71	25	06331-6	RED ELECTRIC WIRE, 12 AWG	38	1	EPS452	ETHERNET SWITCH
72	72	04131-6	RED ELECTRIC WIRE, 8 AWG	39	1	ETR6520	CONDUIT CONNECTOR, 1/2
73	25	07131-5	WHITE ELECTRIC WIRE, 14 AWG	40	1	ETR6522	PLASTIC CONDUIT LOCKNUT, 1/2
74	25	06331-5	WHITE ELECTRIC WIRE, 12 AWG	41	1	EPS499	NAMEPLATE
75	72	04131-5	WHITE ELECTRIC WIRE, 8 AWG	42	2	WD10X30W1M	WIRE DUCT
76	287	42-54092663	WHITE ELECTRIC WIRE, 18 AWG	43	1	EPS446	USB ADAPTER
77	35	42-54092705	GREEN ELECTRIC WIRE, 18 AWG	44	2	M5801-01-1138	RIGHT ANGLE FEMALE CONNECTOR
78	12	PX534	CABLE, 8/4	45	1	M5801-07-08	HIGH VOLTAGE LABEL
79	94	597-18	FERRULE, 18AWG	46	1	EPS447	LEGEND PLATE
80	13	597-16	FERRULE, 16AWG	47	1	PX408	PUSHBUTTON
81	12	597-14	FERRULE, 14AWG	48	1	130AFFT	HEX HEAD CAP SCREW, 1/4-20 X 1-1/4
82	12	597-12	FERRULE, 12AWG	49	2	595-3	EXTERNAL TOOTH LOCK WASHER, 1/4
83	12	597-8	FERRULE, 8AWG	50	2	171A	HEX NUT, 1/4-20
84	1	598-6G	FUSE, 6A	51	2	PX532	COMPRESSION LUG, 8AWG
85	4	598-1G	FUSE, 1A	52	7	PX533	RING TERMINAL
86	1	PTR425	HEAT SHRINK TUBING, .19 ID	53	3	ETR6421	SPACER
87	1	EPS453	USB CABLE, 6'	54	5	ETR6508	FUSE HOLDER
88	2	PX524	RELAY W/ SOCKET	55	1	PTR407	JUMPER, 24 POLE
89	22	41-90096A827	THREAD-CUTTING SCREW, #10-32	56	1	EPS412	TERMINAL BLOCK CABLE
90	2	595-2	EXTERNAL TOOTH LOCK WASHER, #6	57	4	542A	LOW HEAD CAP SCREW, 1/4-20 X 1/2
91	2	171T	HEX NUT, #6-32	58	1	EPS448	ETHERNET CABLE, 1'
92	2	P8597-55	BUTTON HEAD CAP SCREW, #6-32 X 1/2	59	3	EPS449	ETHERNET CABLE, 3'
93	1	ET19455T5	TIPPING MARKER	60	1	EPS415	MOTOR ENCODER CABLE
94	1	EPS456	POWER DISTRIBUTION BLOCK	61	1	EPS416	MOTOR POWER CABLE
95	2	EPS457	COMB BUSBAR	62	1	EPS425	MOTOR ENCODER CABLE
96	3	EPS458	BOX TYPE WIRING LUG	63	1	EPS426	MOTOR POWER CABLE
97	1	EPS459	WIRING LUG SAFETY COVER	64	761	PTR421	BLUE ELECTRIC WIRE, 18 AWG
				65	78	M5801-01-2186	BLACK ELECTRIC WIRE, 16 AWG
				66	25	07131-7	BLACK ELECTRIC WIRE, 14 AWG

PARTS LISTS & DIAGRAMS

Control Panel

ITEM	QTY	PART NUMBER	DESCRIPTION
1	1	PX522	DIN RAIL, 50CM
2	12	ETR6510	END BRACKET
3	1	PX512	24VDC POWER SUPPLY, 240W
4	1	EPS443	ETHERNET ADAPTER
5	1	PX406	SELECTOR SWITCH
6	1	PX410	E-STOP PUSHBUTTON
7	1	EPS410	SERVO DRIVE, 1.5 KW, 230V
8	1	EPS420	SERVO DRIVE, 3.0 KW, 230V
9	1	EPS411	TERMINAL BLOCK MODULE
10	2	EPS438	DRIVE CONTACTOR, 24V
11	1	EPS403	HMI TOUCHSCREEN, 7"
12	1	EPS430	MOLDED CASE CIRCUIT BREAKER, 30A
13	1	EPS431	ROTARY HANDLE
14	1	EPS431A	ROTARY HANDLE SHAFT
15	1	EPS437	SUPPLEMENTARY PROTECTOR, 4A
16	1	EPS436	SUPPLEMENTARY PROTECTOR, 8A
17	1	EPS435	SUPPLEMENTARY PROTECTOR, 15A
18	1	EPS514	CORD GRIP
19	1	PTR408	HOUR METER, 24VDC
20	1	EPS455	CORD GRIP, ALUMINUM
21	3	PTR410	CABLE TIE MOUNT
22	1	EPS401	ENCLOSURE
23	1	EPS402	SUBPANEL
24	2	EPS441	WRAPAROUND CORD GRIP
25	2	EPS442	CORD GRIP INSERT
26	1	EPS417	FLANGE MOUNT RECEPTACLE, SOCKET
27	1	EPS405	POWER ON/OFF PUSH BUTTONS
28	4	P8597-18	BUTTON HEAD CAP SCREW, #8-32 X 3/8
29	1	ETR6407	CORD GRIP
30	2	M5631D14	LOCK NUT, 1/2
31	2	EPS444	ADAPTER CAP
32	9	P8302-142	SOCKET HEAD CAP SCREW, M5 X 10
33	18	PTR420	TERMINAL BLOCK

PARTS LISTS & DIAGRAMS

Powerhead

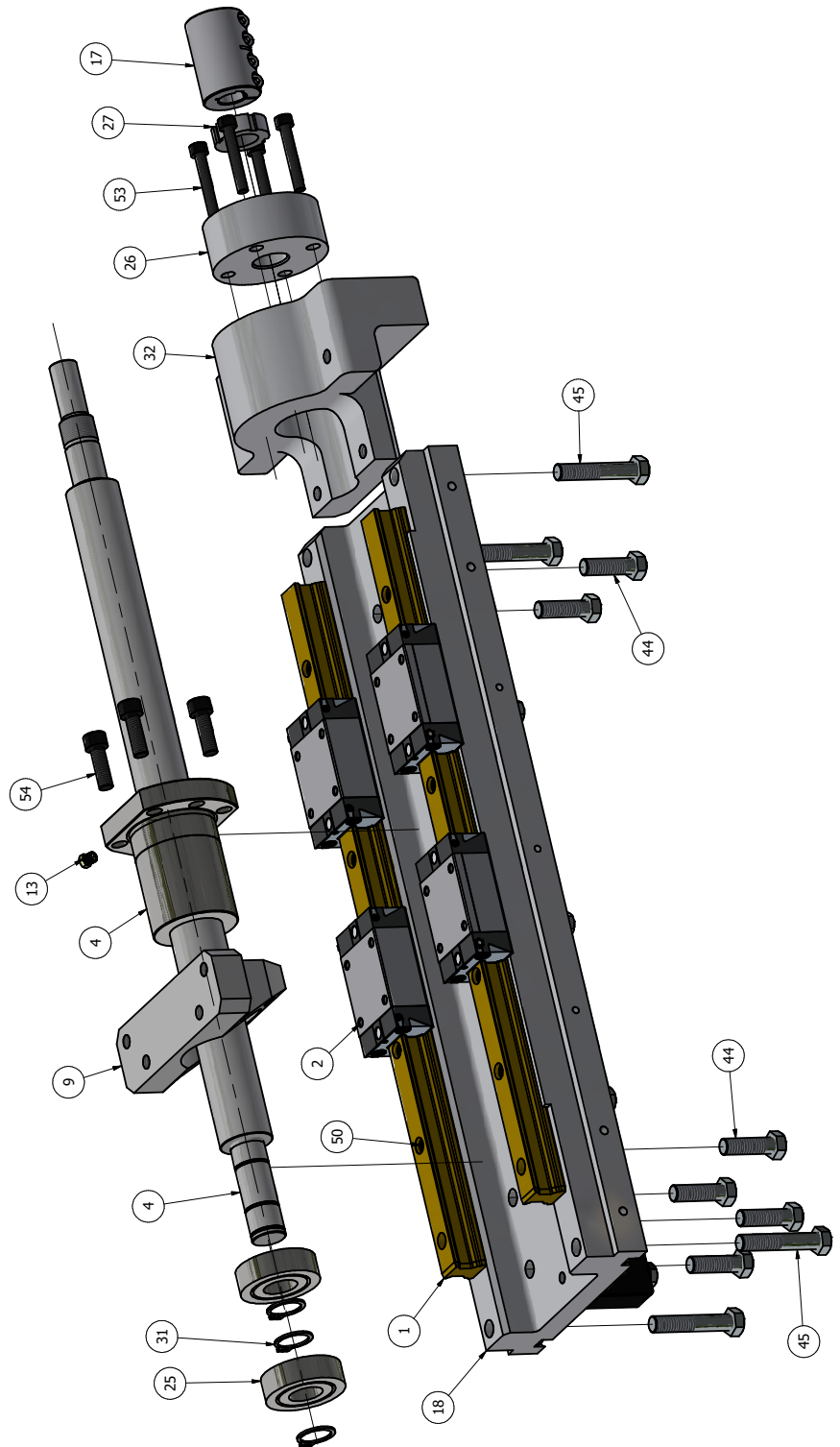

PARTS LISTS & DIAGRAMS

Powerhead

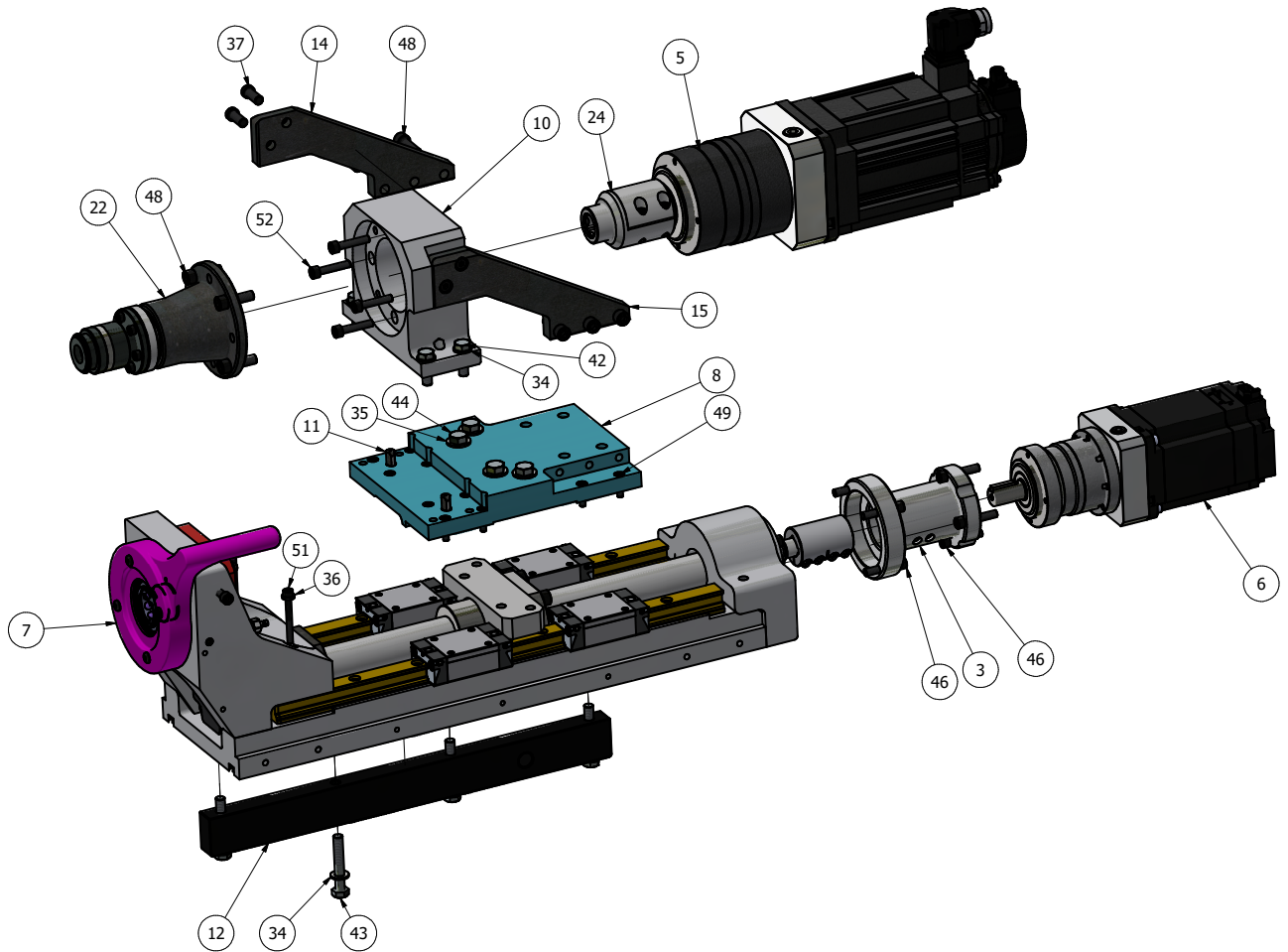

PARTS LISTS & DIAGRAMS

Powerhead

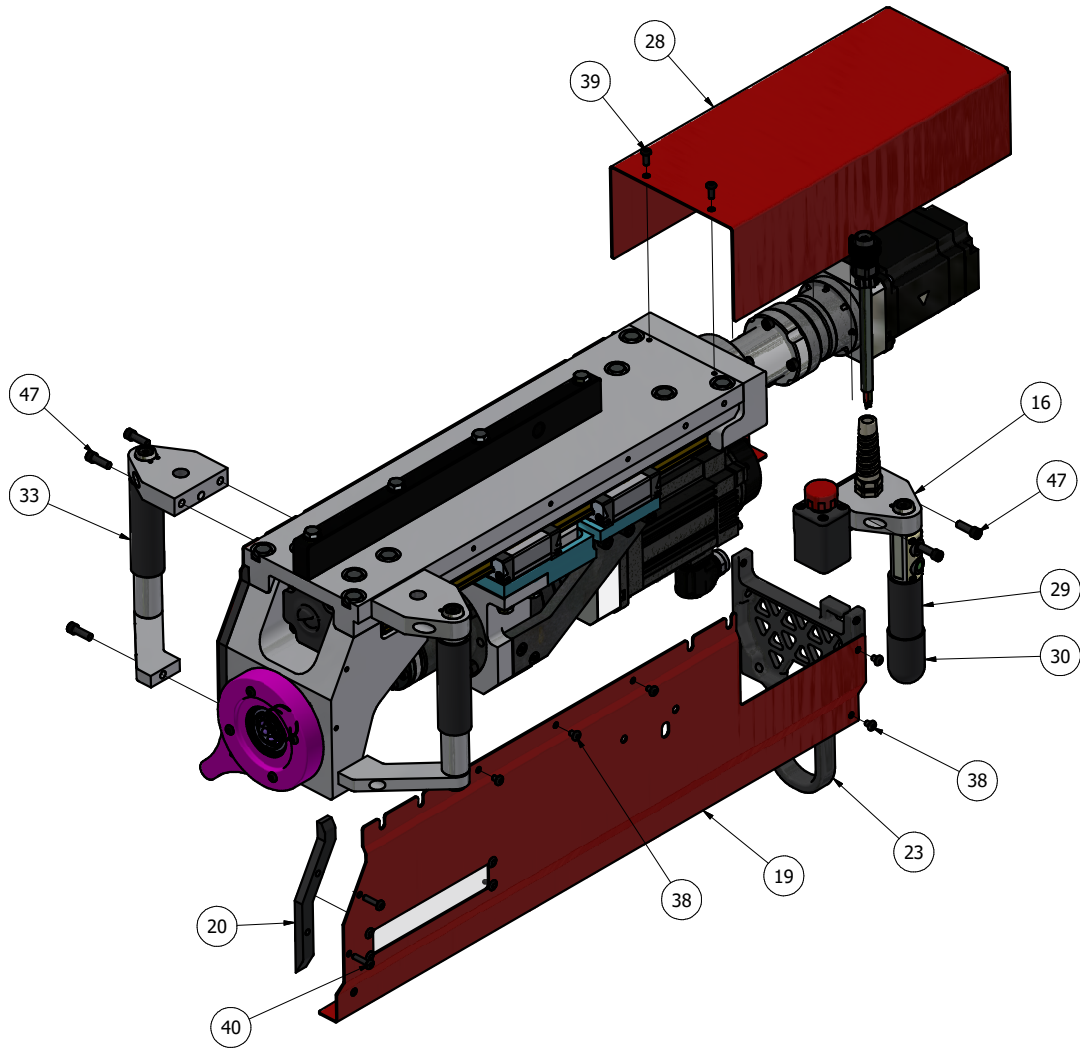

PARTS LISTS & DIAGRAMS

Powerhead

PARTS LIST				PARTS LIST			
ITEM	QTY	PART NUMBER	DESCRIPTION	ITEM	QTY	PART NUMBER	DESCRIPTION
1	2	EPS141	RAIL	30	1	EPS155	HANDLE CAP
2	4	EPS142	RUNNER BLOCK	31	3	P8375-80	RETAINING RING, EXTERNAL
3	1	EPS119	MOTOR COUPLING	32	1	EPS117	REAR BALL SCREW SUPPORT
4	1	EPS140	BALL SCREW	33	1	EPS152	HANDLE ASSEMBLIES
5	1	EPSM179-230	S7A SERVO GEAR MOTOR, 2.5 KW, 230V	34	8	132B	WASHER, 5/16
6	1	EPSM178-230	S7A SERVO GEAR MOTOR, 1.0 KW, 230V	35	14	132C	WASHER, 3/8, SAE
7	1	EPS120	FRONT MOUNT ASSEMBLY	36	2	132Y	WASHER, M5
8	1	EPS130	RUNNER PLATE	37	4	542W	LOW HEAD CAP SCREW, 5/16-18 X 3/4
9	1	EPS186	THRUST FLANGE	38	12	P8597-7	BUTTON HEAD CAP SCREW, #10-32 X 1/4
10	1	EPS115	SPINDLE MOTOR MOUNT	39	2	P8597-1	BUTTON HEAD CAP SCREW, #10-32 X 1/2
11	2	41-8472A22	LOCATING PIN	40	4	P8597-23	BUTTON HEAD CAP SCREW, #10-32 X 3/4
12	1	EPS136	LEVELING BAR	41	2	P8597-53	BUTTON HEAD CAP SCREW, 1/4-20 X 1/4
13	1	41-2421K31	ZERK FITTING, FLUSH MOUNT M6	42	4	130BE	HEX HEAD CAP SCREW, 5/16-18 X 1
14	1	EPS108R	RIGHT GUSSET	43	4	130BJ	HEX HEAD CAP SCREW, 5/16-18 X 2
15	1	EPS108L	LEFT GUSSET	44	10	130CF	HEX HEAD CAP SCREW, 3/8-16 X 1-1/4
16	1	EPS162	CONTROL HANDLE ASSEMBLY	45	4	130CJ	HEX HEAD CAP SCREW, 3/8-16 X 2
17	1	EPS171	MOTOR DRIVE CONNECTOR	46	8	P8302-48	SOCKET HEAD CAP SCREW, 1/4-20 X 1-1/4
18	1	EPS110	LINEAR RAIL BASE	47	8	P8302-26	SOCKET HEAD CAP SCREW, 1/4-20 X 3/4
19	1	EPS160	SIDE PANELS	48	10	P8302-66	SOCKET HEAD CAP SCREW, 5/16-18 X 1
20	1	EPS161R	PANEL SPACER, RIGHT	49	16	P8302-177	SOCKET HEAD CAP SCREW, M5 X 15
21	1	EPS161L	PANEL SPACER, LEFT	50	12	P8302-178	SOCKET HEAD CAP SCREW, M5 X 20
22	1	EPS198	SPINDLE NOSE ASSEMBLY	51	2	P8302-219	SOCKET HEAD CAP SCREW, M5 X 45
23	1	EPS163	REAR GUARD SUPPORT	52	4	P8302-174	SOCKET HEAD CAP SCREW, M6 X 30
24	1	EPS170	MOTOR DRIVE CONNECTOR	53	4	P8302-215	SOCKET HEAD CAP SCREW, M6 X 40
25	2	EPS144	RADIAL BALL BEARING	54	4	P8302-217	SOCKET HEAD CAP SCREW, M8 X 25
26	1	EPS145	ANGULAR CONTACT BEARING, FLANGED				
27	1	EPS146	SLOTTED NUT				
28	1	EPS112	REAR GUARD				
29	1	EPS154	HANDLE GRIP				

PARTS LISTS & DIAGRAMS

EPS460 Assembly

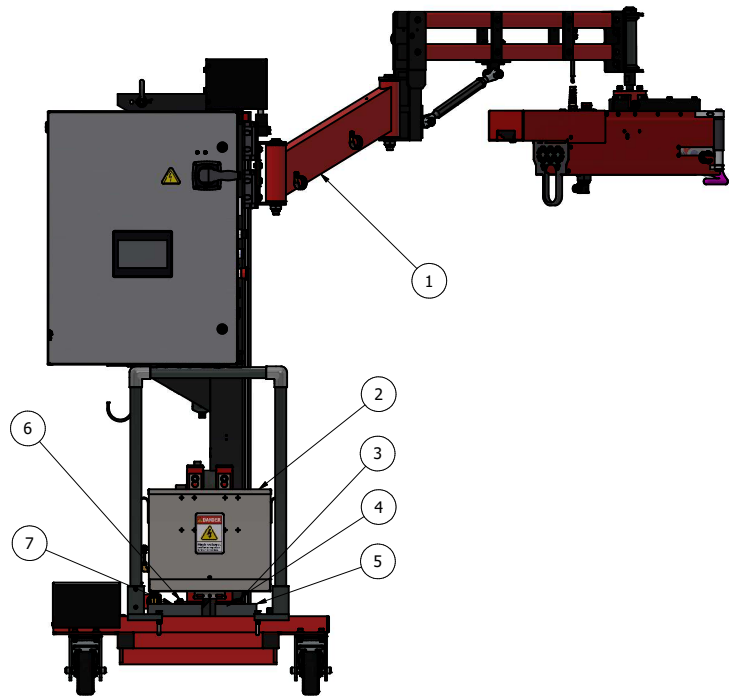
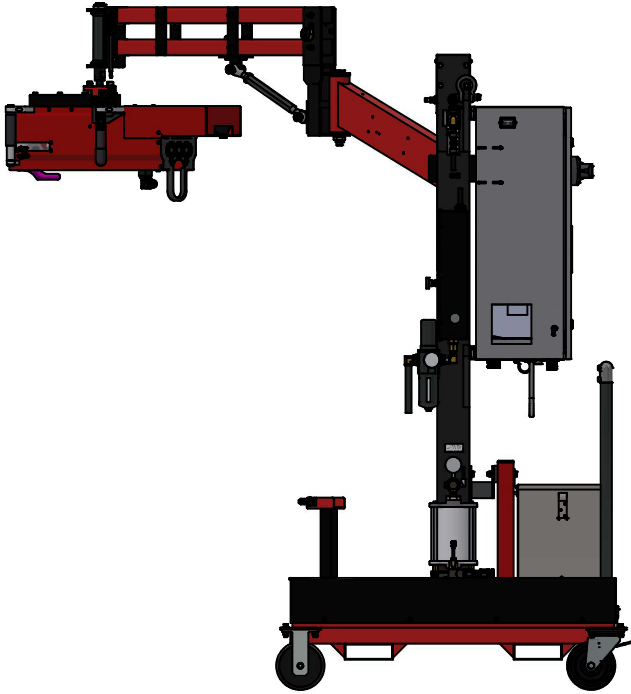

PARTS LISTS & DIAGRAMS

EPS460 Assembly

PARTS LIST			
ITEM	QTY	PART NUMBER	DESCRIPTION
1	1	EPS230	ULTRA HAWK 230V
2	1	EPS2150	TRANSFORMER W/STAND, 460 VAC TO 208Y
3	1	163CJ	HEX HEAD CAP SCREW, 3/8-24 X 1-1/4
4	5	132C	WASHER, 3/8, SAE
5	1	EPS2156	TRANSFORMER LOWER SPACER B
6	1	163CU	HEX HEAD CAP SCREW, 3/8-24 X 3-3/4
7	1	EPS2155	TRANSFORMER LOWER SPACER A
8	4	EPS2174	UNTHREADED BUMPER
9	3	163CS	HEX HEAD CAP SCREW, 3/8-24 X 3-1/4

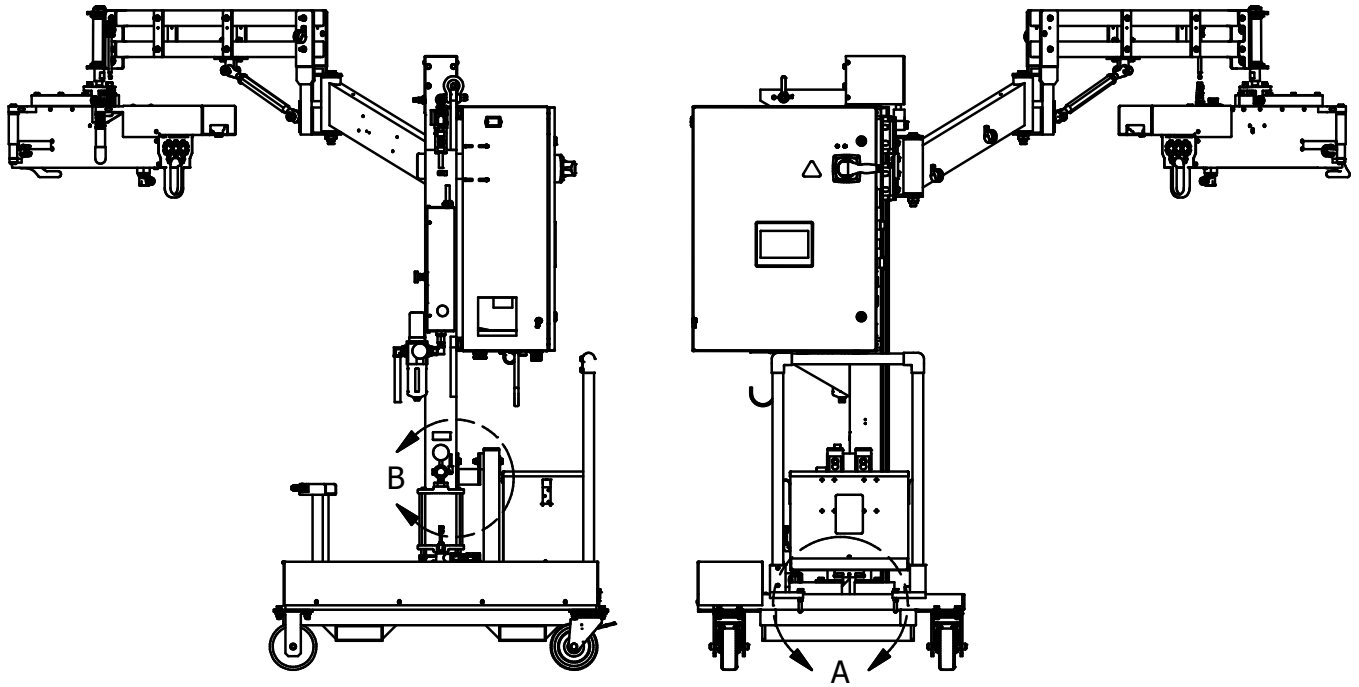

DETAIL B

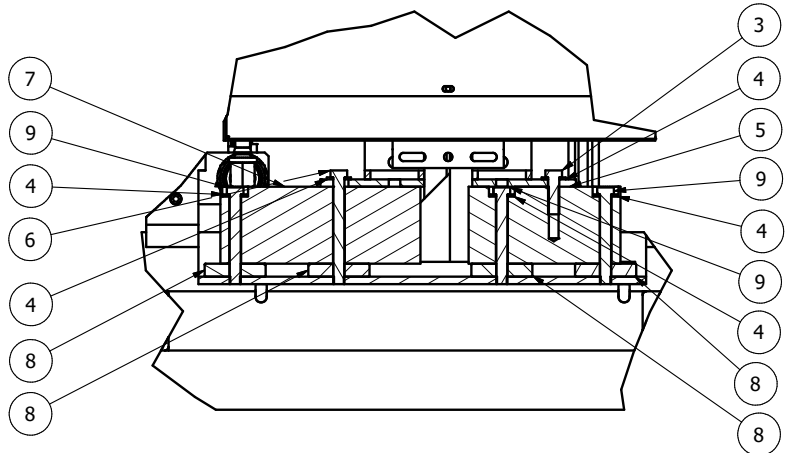
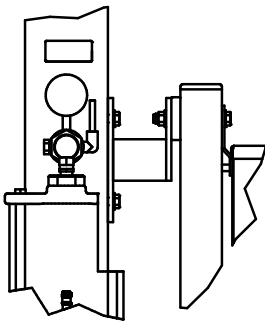

PARTS LISTS & DIAGRAMS

EPS230 Assembly

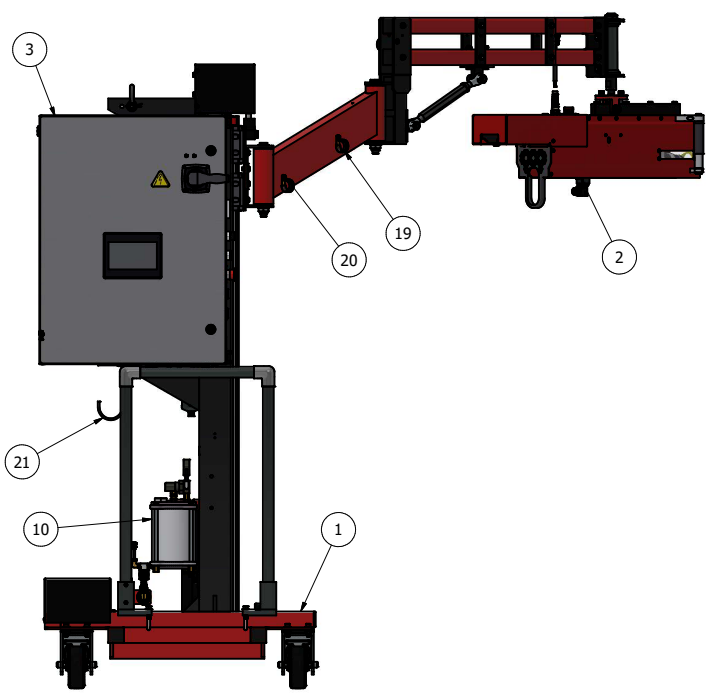
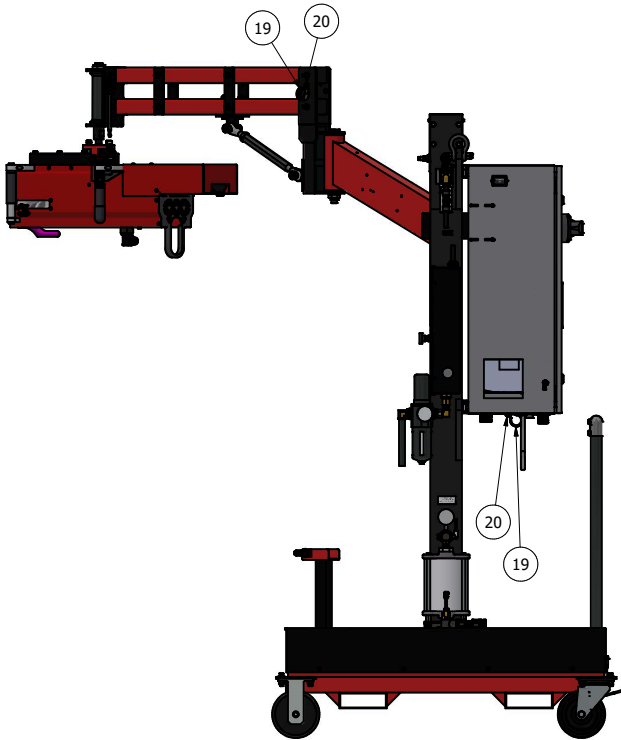

PARTS LISTS & DIAGRAMS

EPS230 Assembly

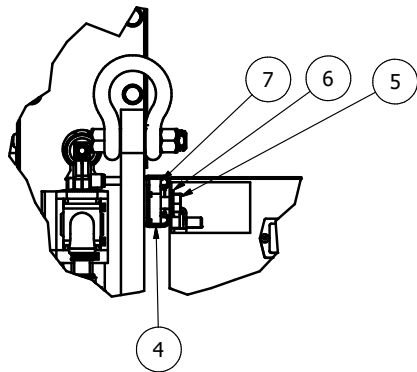
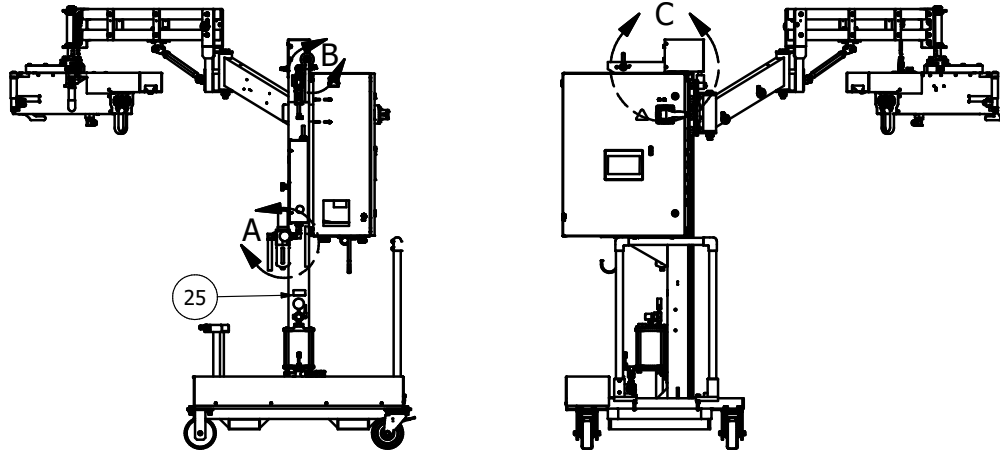

DETAIL B

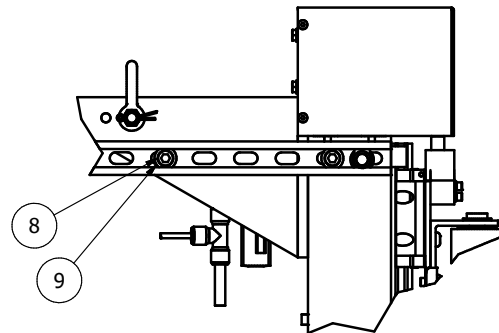

DETAIL C

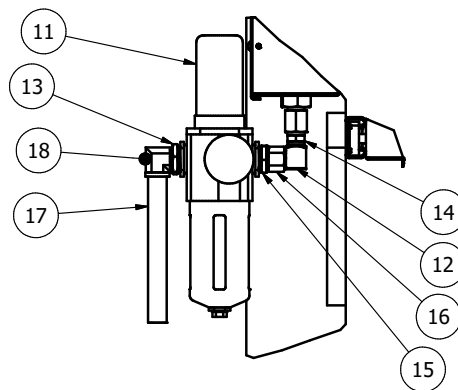

DETAIL A

PARTS LISTS & DIAGRAMS

EPS230 Assembly

PARTS LIST			
ITEM	QTY	PART NUMBER	DESCRIPTION
1	1	EPS	ULTRA HAWK BASE MACHINE
2	1	EXEPS100	POWERHEAD
3	1	EPS400	CONTROL PANEL
4	2	41-3310T791	STRUT CHANNEL
5	4	130CC	HEX HEAD CAP SCREW, 3/8-16 X 3/4
6	4	132C	WASHER, 3/8, SAE
7	4	TN228ZN	STRUT CHANNEL NUT
8	4	P8302-148	SOCKET HEAD CAP SCREW, 1/2-20 X 3/4
9	4	132G	WASHER, 1/2 USS
10	1	PTR504	AUTO LUBE PACKAGE
11	1	PTR1134	FILTER/REGULATOR
12	1	41-50785K44	PIPE FITTING, HIGH PRESSURE, 3/8 FEMALE TO MALE, 90°
13	1	41-1491N206	3/4" NPT X 1/2" NPT REDUCER
14	1	41-7768K17	CHECK VALVE
15	1	41-1491N205	3/8 NPT X 3/4 NPT ADAPTER
16	1	41-50785K617	3/8 NPT X 3/8 NPT STRAIGHT ADAPTER
17	24"	EPS5013	1/2" HOSE
18	1	41-91465K66	PUSH ON HOSE FITTING, 1/2 NPT X 1/2 HOSE
19	4	41-3177T17	CABLE LOOP CLAMP
20	4	P8597-20	BUTTON HEAD CAP SCREW, #10-24 X 1/2
21	1	41-19075A17	CORD HOOK
22	1	549-6	WASHER, #10, TYPE A
23	1	171S	HEX NUT, #10-24
24	1	PX652	CAUTION LABEL
25	1	ETR6535	SERVICE LABEL
26	2	P535-6	FLAT HEAD CAP SCREW, #6-32 X 3/8
27	2	132J	WASHER, #6
28	2	P8253-5	ACORN NUT, #6-32 UNC
29	168"	41-5156K87	1/4 TUBING (NOT SHOWN)
30	150"	41-9196K15	EXPANDABLE SLEEVING (NOT SHOWN)

PARTS LISTS & DIAGRAMS

EPS460 Assembly - Extended Reach Package

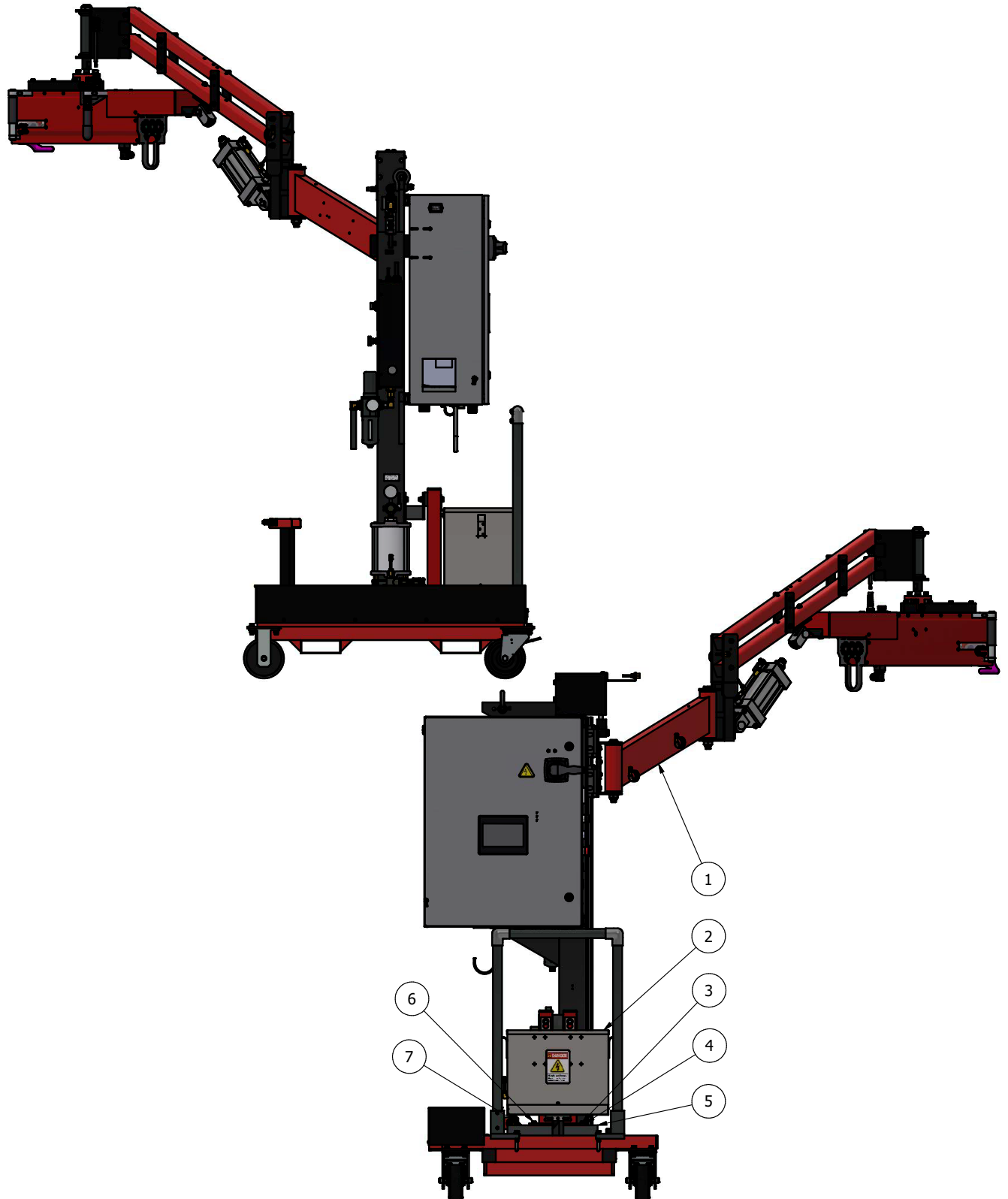

PARTS LISTS & DIAGRAMS

EPS460 Assembly - Extended Reach Package

PARTS LIST			
ITEM	QTY	PART NUMBER	DESCRIPTION
1	1	EPS230E	ULTRA HAWK 230V EXTENDED HEIGHT
2	1	EPS2150	TRANSFORMER W/STAND, 460 VAC TO 208Y
3	1	163CJ	HEX HEAD CAP SCREW, 3/8-24 X 1-1/4
4	5	132C	WASHER, 3/8, SAE
5	1	EPS2156	TRANSFORMER LOWER SPACER B
6	1	163CU	HEX HEAD CAP SCREW, 3/8-24 X 3-3/4
7	1	EPS2155	TRANSFORMER LOWER SPACER A
8	4	EPS2174	UNTHREADED BUMPER
9	3	163CS	HEX HEAD CAP SCREW, 3/8-24 X 3-1/4

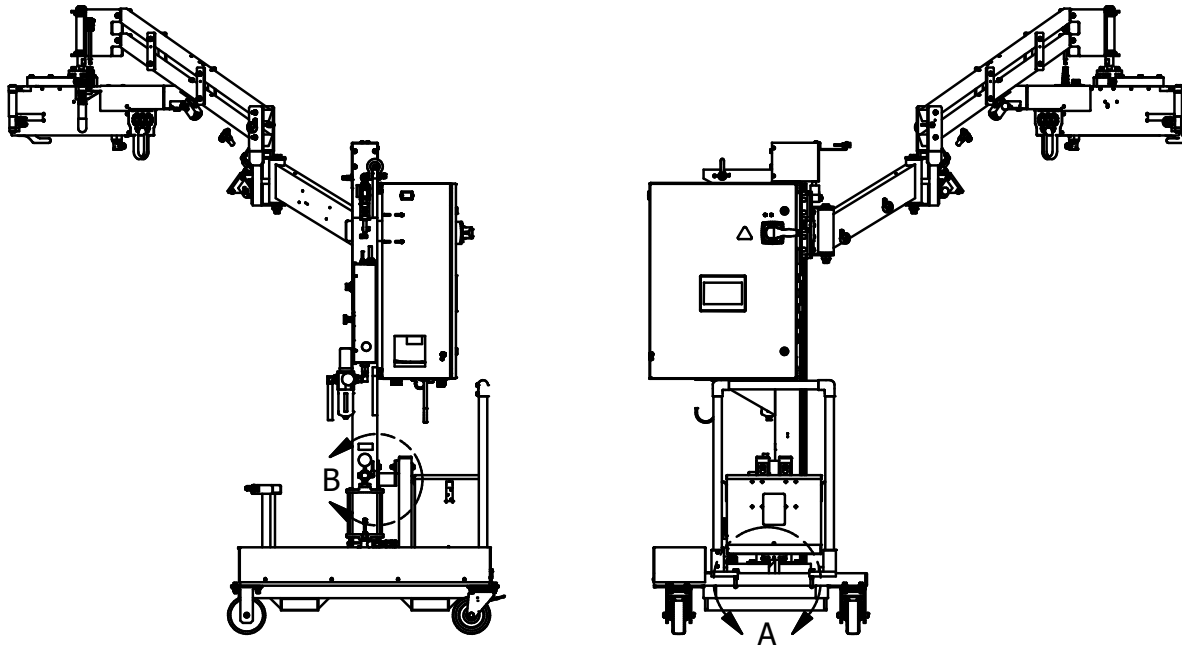

DETAIL B

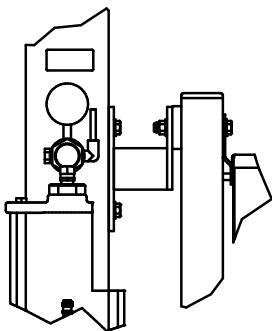

DETAIL A

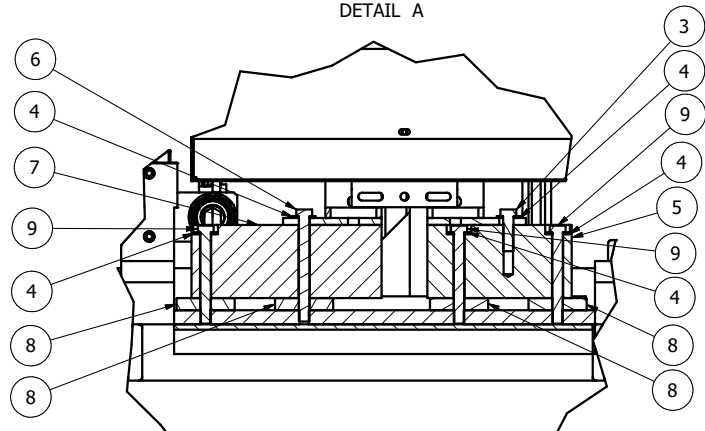

PARTS LISTS & DIAGRAMS

EPS230 Assembly - Extended Reach Package

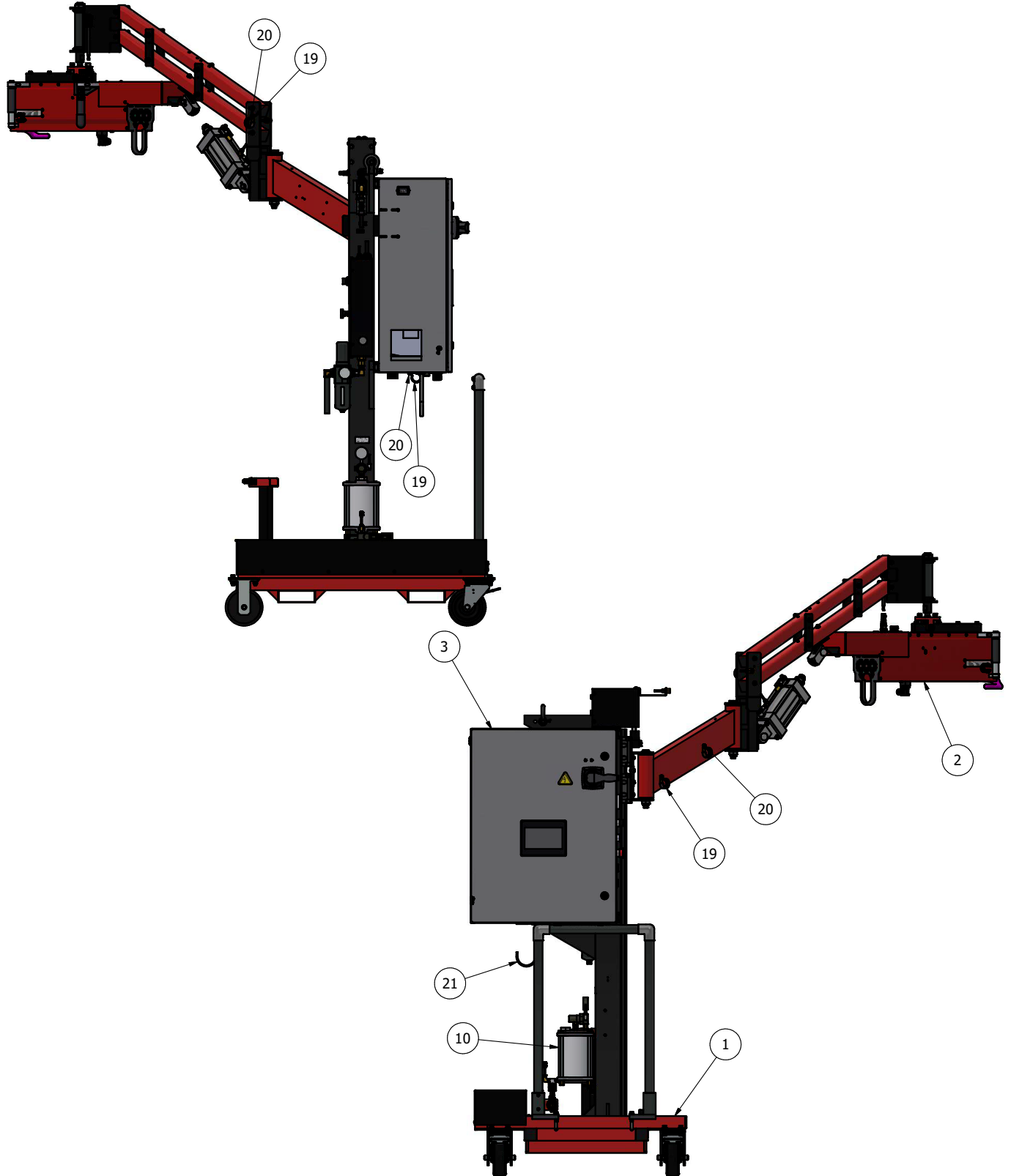

PARTS LISTS & DIAGRAMS

EPS230 Assembly - Extended Reach Package

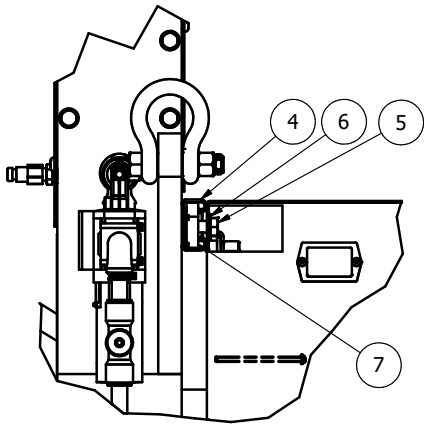
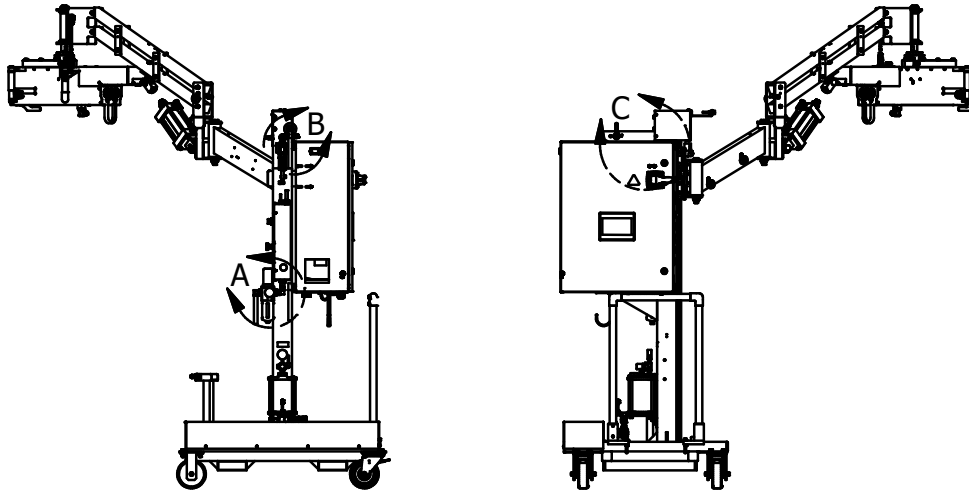

DETAIL B

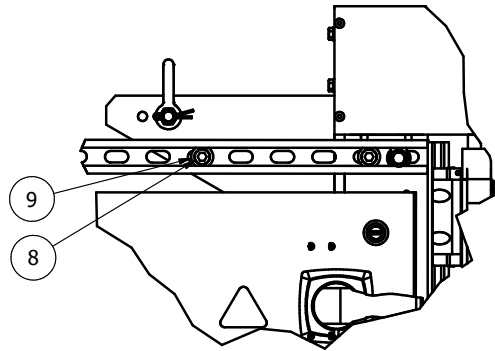

DETAIL C

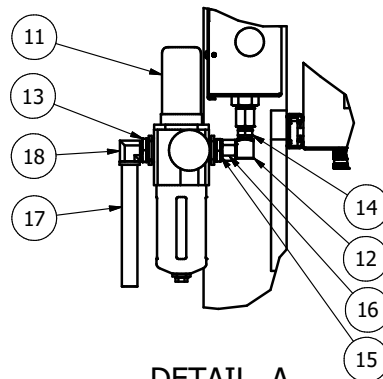

DETAIL A

PARTS LISTS & DIAGRAMS

EPS230 Assembly - Extended Reach Package

PARTS LIST			
ITEM	QTY	PART NUMBER	DESCRIPTION
1	1	EPSE	ULTRA HAWK BASE MACHINE EXT HEIGHT
2	1	EXEPS100	POWERHEAD
3	1	EPS400	CONTROL PANEL
4	2	41-3310T791	STRUT CHANNEL
5	4	130CC	HEX HEAD CAP SCREW, 3/8-16 X 3/4
6	4	132C	WASHER, 3/8, SAE
7	4	TN228ZN	STRUT CHANNEL NUT
8	4	P8302-148	SOCKET HEAD CAP SCREW, 1/2-20 X 3/4
9	4	132G	WASHER, 1/2 USS
10	1	PTR504	AUTO LUBE PACKAGE
11	1	PTR1134	FILTER/REGULATOR
12	1	41-50785K44	PIPE FITTING, HIGH PRESSURE, 3/8 FEMALE TO MALE, 90°
13	1	41-1491N206	3/4" NPT X 1/2" NPT REDUCER
14	1	41-7768K17	CHECK VALVE
15	1	41-1491N205	3/8 NPT X 3/4 NPT ADAPTER
16	1	41-50785K617	3/8 NPT X 3/8 NPT STRAIGHT ADAPTER
17	24"	EPS5013	1/2" HOSE
18	1	41-91465K66	PUSH ON HOSE FITTING, 1/2 NPT X 1/2 HOSE
19	4	41-3177T17	CABLE LOOP CLAMP
20	4	P8597-20	BUTTON HEAD CAP SCREW, #10-24 X 1/2
21	1	41-19075A17	CORD HOOK
22	1	549-6	WASHER, #10, TYPE A
23	1	171S	HEX NUT, #10-24
24	1	PX652	CAUTION LABEL
25	1	ETR6535	SERVICE LABEL
26	2	P535-6	FLAT HEAD CAP SCREW, #6-32 X 3/8
27	2	132J	WASHER, #6
28	2	P8253-5	ACORN NUT, #6-32 UNC
29	168"	41-5156K87	1/4 TUBING
30	150"	41-9196K15	EXPANDABLE SLEEVING (NOT SHOWN)

ELECTRICAL SCHEMATIC

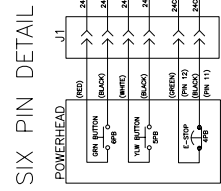
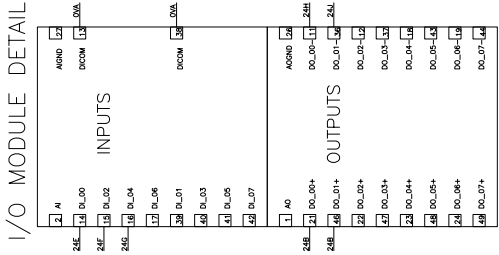
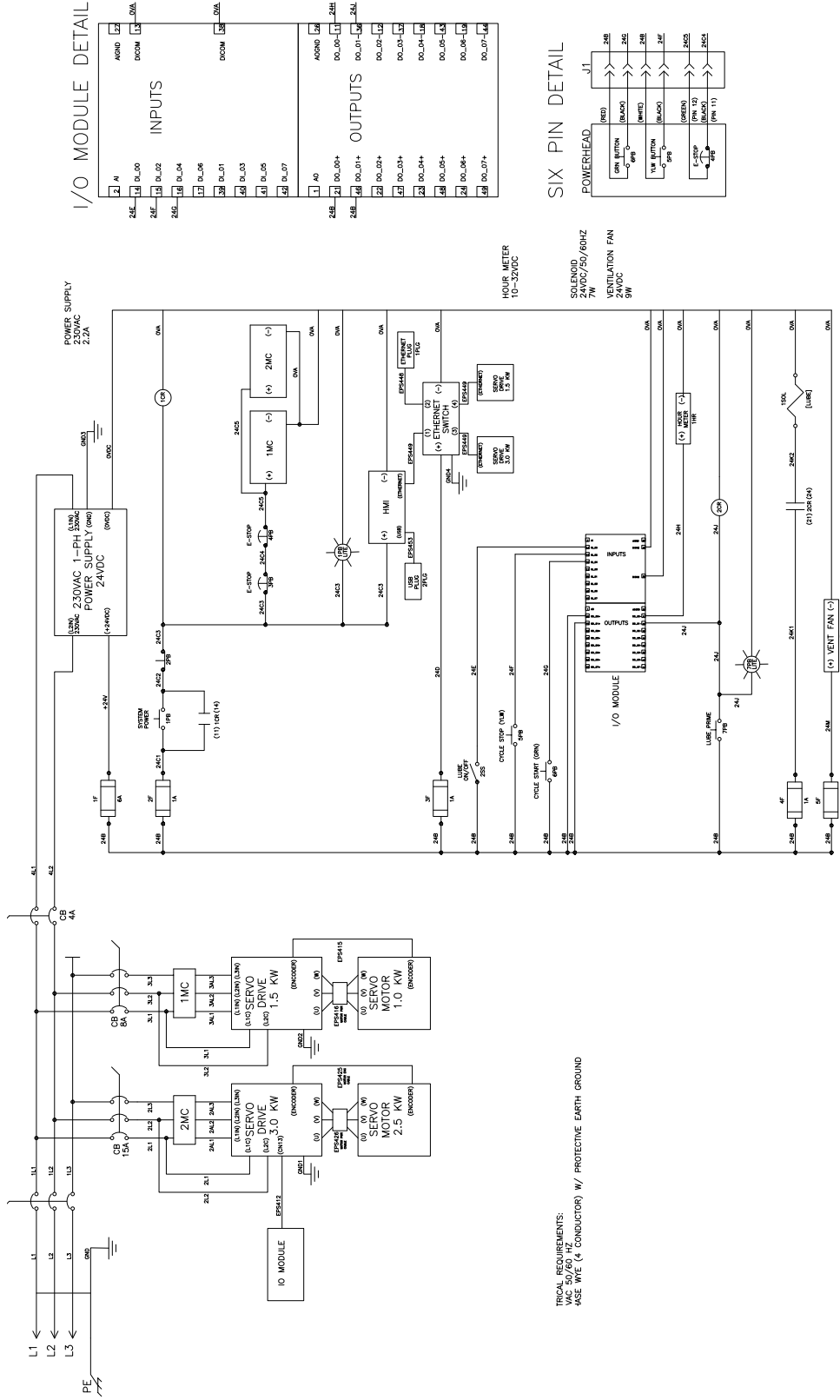

- SOLENOID VALVE 7W
- VENTILATION FAN 24VDC 9W
- HOURLY METER 10-32VDC

TRICAL REQUIREMENTS:
 4/0 AWG (4 CONDUCTOR) W/ PROTECTIVE EARTH GROUND

MAINTENANCE INSTRUCTIONS

WARNING

To reduce the risk of injury, always unplug your machine before performing any maintenance. Never disassemble the machine or try to do any rewiring on the machine's electrical system. Contact Elliott for all repairs.

Before Each Use

1. Inspect filter/regulator/lubricator (FRL) before each use.

Recommended Pneumatic Air Tool Lubricant
BP, Energol E46
Esso, Arox EP46
Mobil, Almo Oil 525
Shell, Torvcula 32
Texaco, Aries 32

- a.) Fill lubricator with the correct oil as necessary. 2 ounces maximum into the small clear reservoir located on the mast.
 - b.) Main regulator should be set at 90 psi max.
2. Inspect all lines before each use.
 - a.) Check for loose air connections.
 - b.) Check for cracks or other damage and replace as necessary.
 3. Inspect for loose or missing bolted connections before each use.
 - a.) Tighten and replace as necessary.

MAINTENANCE INSTRUCTIONS

Bi-Monthly

1. Lubricate linear bearing located on the mast.
 - a.) Grease at a maximum of 1-month intervals.
 - b.) Recommended to use Castrol Tribol GR 100-2 PD or equivalent.
 - c.) Grease fittings are located on power head.
 - d.) To find the grease fittings on the power head, you will need to log into the the Service page on the HMI, then select powerhead homing procedure' - MAKE SURE EXPANDERS ARE NOT INSTALLED & HANDS ARE FREE.
2. Inspect casters.
 - a.) Grease through the grease fittings located at the axles, and the swivel bearings located on the swivel casters, at a maximum of 1-year intervals.
 - b.) Ensure casters are not worn or cracked.
3. Grease the counter balance arm - this grease fitting is located behind the mounting bracket. You can use Castrol Tribol GR 100-2 PD or an equivalent.

To keep your Ultra Hawk in peak operating condition, work diligently to execute the provided checklist below. These recommendations will prolong your system's productivity and the overall lifespan of any major components.

IMPORTANT: These recommendations can vary based off the work load the system will carry each day/month/year.

Daily Checklist

1. Check all lines before each use.
 - a.) Loose connections, damaged hoses/plumbing will need to be replaced or corrected.
2. Test your Emergency Stop Button on the Powerhead and the control panel.
3. Inspect and maintain your FRL (filter/regulator/lubricator) before each shift. **IMPORTANT: DO NOT let oil levels in any reservoir get below 25%.**
 - a.) Small reservoir located on the articulating arm mast – 2 oz. MAX capacity.
 - b.) Visually inspect the filter(s) to ensure they are clean, free of debris or excess lubrication.
4. Inspect the system thoroughly for any signs of loose or missing hardware.
 - a.) Tighten and replace as necessary.
5. Ensure proper alignment of the Power Head using our provided magnetic level.
 - a.) Tighten/loosen the Adjustment Bolts as needed.

MAINTENANCE INSTRUCTIONS

30 Day Checklist

1. Inspect system components for any damaged or missing pieces. Repair or replace as needed.
 - a.) Powerhead – functions properly, “Emergency Stop” button functions, mounted correctly, all hardware accounted for.
 - b.) Articulating Arm – all hardware is accounted for and tight, arm is secured properly to the vertical mast.
 - c.) Counterbalance Mast – cable is in good shape (no damage to outer casing or pinched, relief valve at the top of mast functions as should.
 - d.) Operating Panel (PLC) – check functions of keypad, lubrication switch, “Emergency Stop” button.
 - e.) Lubricate Canister – visually inspect the reservoir for damages, look for any debris and/or white cloudy debris on the top of the lubricant. If you see this, drain all lubricant and replace with new. This is a result of air in the line and/or old lubricant.
2. Inspect hoses/cables/connections for any of the following symptoms:
 - a.) Loose connections.
 - b.) Kinks/crimps/leaks.
 - c.) Damage to outer casing.
3. Lubricate the linear bearing carriages.
 - a.) Located on the top side of the Power Head Assembly, you will find Zerk fittings on either side of the Pillow Block (silver in color).
 - b.) Inject a Grade 2 grease into each Zerk fitting to properly lubricate the liner bearings inside the pillow block. For best results, work the shafts back and forth to ensure you get full coverage of the working area. There is no chance of over lubricating, as excess grease will work its way out the seal at either end .
4. Inspect all (4) Casters.
 - a.) Note and address any damages.
 - b.) Remove any large debris that may have embedded into the wheel.
 - c.) Inject grease into the Zerk fittings located at the axles and swivel bearings.
5. Test vertical reach function.
 - a.) Exercise your Articulating Arm by extending and retracting the cylinder for the vertical boom.

MAINTENANCE INSTRUCTIONS

Loading HMI Program Updates

Items Required:

- Working USB Drive
- UpdatePackage.zip file provided by Elliott

Update Process:

1. Copy the UpdatePackage.zip file directly to the USB drive (the “root directory”).
2. Insert the USB into the I/O Panel of the Ultra Hawk.
3. Click the “Service” page and login as the administrator.
4. Click the “Context Menu” button on the right side of the page and select “Update”.
5. The file chosen at the top should say “/mnt/USBMEMORY”, indicating that it found your update package.
6. Press “Next” and allow the HMI to update and reboot the program on its own.

Troubleshooting:

1. HMI can't find the update package or it does not show “/mnt/USBMEMORY” on the update page automatically.
 - a.) Make sure the update package zip file is in the very top folder of the USB drive.
 - b.) The USB drive may be faulty or not plugged in. Try another USB drive.

TROUBLESHOOTING

SYMPTOM	CAUSE	SOLUTION
General		
Control Screen will not turn on	The main power cable is not connected to a power source	Connect cable to a power source; see the label located on the electrical cabinet.
	The controls display selector switch is set to 'OFF'	Turn the control screen selector switch to 'ON'
The motor will not stop to a torque	Mini 4amp breaker tripped	Flip breaker
	Fuse blown	Replace 1a fuse at 2F location
The motor will not operate	Bad switch(s) in the handle control box	Replace switch(s)
	The green button has not been pressed on the handle	Locate the button, push to engage
	A torque value has not been entered into the control screen	Enter the desired torque value
	The programmable logic controller (PLC) inside the electrical cabinet is not receiving a signal from the control screen	Open the door to the control panel and re-attach the signal plug to the control screen module
		Replace the control screen module and/or cable
	The PLC inside the electrical cabinet is not receiving a signal from the handle controls	Loose cable connection from the handle controls to the electrical cabinet
		Loose connection in the handle control box
		Bad cable, replace as necessary
Bad control button, replace as necessary		
Bad connection at J1 4-pin connector located at the bottom of the control box	Remove connector, clean pin terminal, and reinstall	
Drive Error	Check and record flashing error code on servo drive. Contact manufacturer.	
Auto-Lubrication		
No air pressure to tank	The air control valve on the side of the Ultra Hawk control panel is turned off.	Turn the air control valve on
Too much lubricant	The flow control valve needs adjusting	Decrease the flow on the HMI to desired amount
Too little lubricant	The flow control valve needs adjusting	Increase the flow on the HMI to the desired amount

TECHNICAL INFORMATION

Ultra Hawk Specifications	
Power	
Pneumatic Requirements	1.5 CFM, 100 PSI
Power Requirements*	EPS230: 230 V, 3 Phase, 60 Hz
	EPS460: 460 V, 3 Phase, 60 Hz
Specifications	
Maximum Torque Absorption	135 ft. lbs
Maximum Weight Supported	185 lbs (83.9 Kg)
Horizontal Radius Reach	5.5' (1.68 m)
Minimum Vertical Reach	2' (610 mm)
Maximum Vertical Reach	8' (2.44 m)
Tube OD Range	0.5" - 1-1/2" (12.7mm - 38.1mm)
Transport Methods	Forklift Pockets, Hoist Ring, Casters

Ultra Hawk Specifications	
Dimensions & Weight	
Working Area/Footprint	119" (3.02 m) maximum height
	79" (2.01 m) minimum height
	43" (1.09 m) width
	95" (2.41 m) maximum depth
	34" (864 mm) minimum depth
Unit Weight	1100 lbs. (499 Kg)
Shipping Dimensions (crated)	87" (2.24 m) height
	56" (1.27 m) width
	65" (1.02 m) depth
Shipping Weight (crated)	1400 lbs. (635 Kg)
* May require removal of supplied plug & installation of plug suitable based on locality requirement.	

WARRANTY

Should any part, of Seller's own manufacture, prove to have been defective in material or workmanship when shipped (as determined by Seller), Seller warrants that it will, at its sole option, repair or replace said part f.o.b., point of manufacture, provided that Buyer notifies, in writing, of such defect within twelve (12) months from date of shipment from the manufacturing plant.

On request of Seller, the part claimed to be defective will be returned, transportation, insurance, taxes and duties prepaid, to the factory where made, for inspection. Any item, which has been purchased by Seller, is warranted only to the extent of the original manufacturer's warranty to Seller. Seller shall not be liable for any damages or delays caused by defective material or workmanship.

No allowance will be made for repairs or alterations made by others without Seller's written consent or approval. If repairs or alterations are attempted without Seller's consent, Seller's warranty is void.

THE WARRANTIES PROVIDED IN THE OBLIGATIONS AND LIABILITIES OF SELLER HEREUNDER, AND THE RIGHTS AND REMEDIES OF BUYER HEREUNDER ARE EXCLUSIVE AND IN SUBSTITUTION FOR, AND BUYER HEREBY WAIVES ALL OTHER WARRANTIES, GUARANTEES, OBLIGATIONS, CLAIMS FOR LIABILITIES, RIGHTS AND REMEDIES, EXPRESS OR IMPLIED, ARISING BY LAW OR OTHERWISE, INCLUDING BUT NOT LIMITED TO THE IMPLIED WARRANTY FOR MERCHANTABILITY AND FITNESS FOR PURPOSE.

Seller's total liability is limited to the lower of the cost of repair or replacement.

This page intentionally left blank.

This page intentionally left blank.



Contact Us

Elliott Tool offers a complete line of precision tube tools to meet your needs. Contact us or your local support.

Elliott Tool Technologies, Ltd.
1760 Tuttle Avenue
Dayton, Ohio 45403-3428
Phone: +1 937 253 6133 • +1 800 332 0447
Fax: +1 937 253 9189
www.elliott-tool.com

Printed in the USA
©12/2023 Elliott Tool Technologies, Ltd.
TM-155
PL-134

Locally Supported By:

www.elliott-tool.com/support