

ID MULTI-ROLLER BURNISHING TOOL

INSTALLATION AND OPERATING INSTRUCTIONS

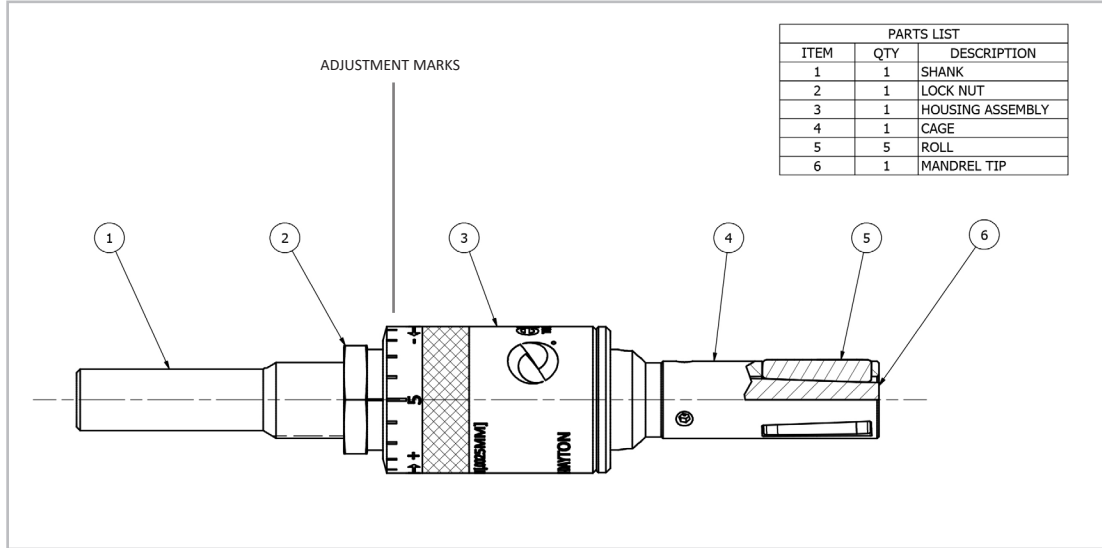

Setting the burnishing tool:

1. Loosen the lock nut on the tool.
2. Pull back on the housing and turn it to the right to decrease the diameter so that the tool will fit into the part to be burnished.
3. Once the tool easily slides into the part, begin to rotate the housing to the left to increase the diameter of the tool until the rolls come in contact with the surface of the part and then withdraw the tool from the part.
4. Using the incremental adjustment marks (.0001"/.0025mm) on the housing, adjust the diameter of the tool for the amount of stock left in the bore (per chart below) and tighten the lock nut.
5. The final setting is determined by burnishing a work piece and measuring the size and surface finish. It is not recommended to burnish a part more than twice (see Notes). Be sure to tighten lock nut after each adjustment.

	Workpiece Size Range	Stock Allowance (in)	Stock Allowance (mm)	Pre-Burnished Finish (μ in)	Pre-Burnished Finish (μ mm)	Burnished Finish (μ in)	Burnished Finish (μ mm)
High Ductility	0.125 - 0.484" (3.91 - 12.29mm)	0.0004 - 0.0007	0.0100 - 0.0180	80-125	2.0 - 3.1	4-10	0.10 - 0.25
	0.500 - 1.000" (12.70 - 25.40mm)	0.0007 - 0.0015	0.0180 - 0.0380	60-125	1.5 - 3.1	4-10	0.10 - 0.25
	1.031 - 2.000" (26.19 - 50.80mm)	0.0010 - 0.0020	0.0240 - 0.0510	60-125	1.5 - 3.1	4-10	0.10 - 0.25
	2.031 - 6.500" (51.59 - 165.10mm)	0.0015 - 0.0030	0.0380 - 0.0760	60-200	1.5 - 3.0	4-10	0.10 - 0.25
Low Ductility	0.125 - 0.484" (3.91 - 12.29mm)	0.0004 - 0.0007	0.0100 - 0.0178	80-100	2.0 - 2.5	12-24	0.30 - 0.60
	0.500 - 1.000" (12.70 - 25.40mm)	0.0007 - 0.0015	0.0180 - 0.0250	90-125	2.3 - 3.1	12-24	0.30 - 0.60
	1.031 - 2.000" (26.19 - 50.80mm)	0.0010 - 0.0020	0.0250 - 0.0380	125-180	3.1 - 4.5	12-24	0.30 - 0.60
	2.031 - 6.500" (51.59 - 165.10mm)	0.0015 - 0.0030	0.0380 - .0.0510	120-200	3.0 - 5.0	12-24	0.30 - 0.60

Recommended Feeds and Speeds

Diameter (in)	Diameter (mm)	Feed Rate* (Inch/Rev)	Feed Rate* (Metric/Rev)	Speed RPM
0.154 - 0.246	3.910 - 6.250	0.005 - 0.009	0.127 - 0.229	1500 to 3000
0.247 - 0.371	6.270 - 9.420	0.008 - 0.012	0.203 - 0.305	1500 to 3000
0.372 - 0.495	9.450 - 12.570	0.012 - 0.019	0.305 - 0.483	1000 to 2000
0.496 - 0.620	12.600 - 15.750	0.014 - 0.020	0.356 - 0.508	1000 to 2000
0.621 - 0.745	15.770 - 18.920	0.019 - 0.027	0.482 - 0.686	600 to 1200
0.746 - 0.870	18.950 - 22.100	0.022 - 0.035	0.559 - 0.889	600 to 1200
0.871 - 0.995	22.120 - 25.270	0.025 - 0.037	0.635 - 0.940	600 to 1200
0.996 - 1.245	25.300 - 31.620	0.032 - 0.049	0.813 - 1.245	300 to 600
1.246 - 1.495	31.650 - 37.970	0.048 - 0.071	1.219 - 1.803	300 to 600
1.496 - 1.745	38.000 - 44.320	0.056 - 0.084	1.422 - 2.134	200 to 400
1.746 - 1.995	44.350 - 50.670	0.057 - 0.086	1.448 - 2.184	200 to 400
1.996 - 2.245	50.700 - 57.020	0.070 - 0.105	1.778 - 2.667	200 to 400
2.246 - 2.495	57.050 - 63.370	0.075 - 0.112	1.905 - 2.845	170 to 340
2.496 - 2.745	63.400 - 69.720	0.082 - 0.124	2.082 - 3.150	170 to 340
2.746 - 2.995	69.750 - 76.070	0.054 - 0.080	1.372 - 2.032	170 to 340
2.996 - 3.245	76.100 - 82.420	0.056 - 0.084	1.422 - 2.134	120 to 240
3.246 - 3.495	82.450 - 88.770	0.061 - 0.091	1.549 - 2.311	120 to 240
3.496 - 3.745	88.800 - 95.120	0.074 - 0.104	1.880 - 2.642	100 to 200
3.746 - 3.995	95.150 - 101.470	0.078 - 0.116	1.981 - 2.946	100 to 200
3.996 - 4.245	101.500 - 107.820	0.081 - 0.121	2.057 - 3.073	100 to 200

**Do not run the tool slower than the minimum recommended feed rate.*

Lubrication

- A continuous stream of clean lubricant, in sufficient volume to clean and flush the tool and work piece, should be provided during operation.
- Use any standard grade of lightweight, low viscosity lubricating oil for most metals. Water soluble liquids are acceptable (an 8%+ concentration is recommended). For aluminum or magnesium alloys, a highly refined paraffin base oil of low viscosity will work well.
- In a drill press operation without coolant capabilities, apply a sufficient amount of clean lubricant onto the tool or part.

Routine Maintenance

- Examine rolls, cages and mandrels for wear or damage at regular intervals and replace when necessary.
- Replace a complete set of rolls each time.
- Before storing the tool, clean the tool and apply rust preventative to entire tool.
- Before returning the tool to service, double-check the rolls and mandrels for pitting or rusting. Replace parts as needed.

Alignment

- It is important that the tool and work piece be properly aligned. A minimal misalignment of .003" to .004" (.076mm - .101mm) will not adversely affect the tool or surface finish. The higher the alignment deviation, the more bending stresses can occur. This can lead to fatigue and failure of the mandrel tip. Correct alignment is more important when the tool rotates.
- The tool shank should be rigidly mounted in the spindle to prevent axial movement during the release cycle. This is particularly important in the case of large, heavy tools that work in a vertical position. In multiple spindle automatics, the tool should be mounted in a top position in order to minimize chip contamination from other metal cutting operations. When a tool is used on a horizontal plane, a generous chamfer lead-in to the work piece is required to better align the tool as it enters the bore.

Notes

- A continuous stream of clean lubricant, in sufficient volume to clean and flush the tool and work piece, should be provided during operation.
- Do not burnish a piece more than twice, due to work-hardening of the material. This may cause flaking and incorrect tool setting.
- For optimal results when burnishing harder materials, the RPM may need to be reduced below recommended values.

For additional technical support:

1-800-332-0447
sales@elliott-tool.com
www.elliott-tool.com