

ID/OD CARBIDE ROLL BORING BAR STYLE BURNISHING TOOL

INSTALLATION AND OPERATING INSTRUCTIONS

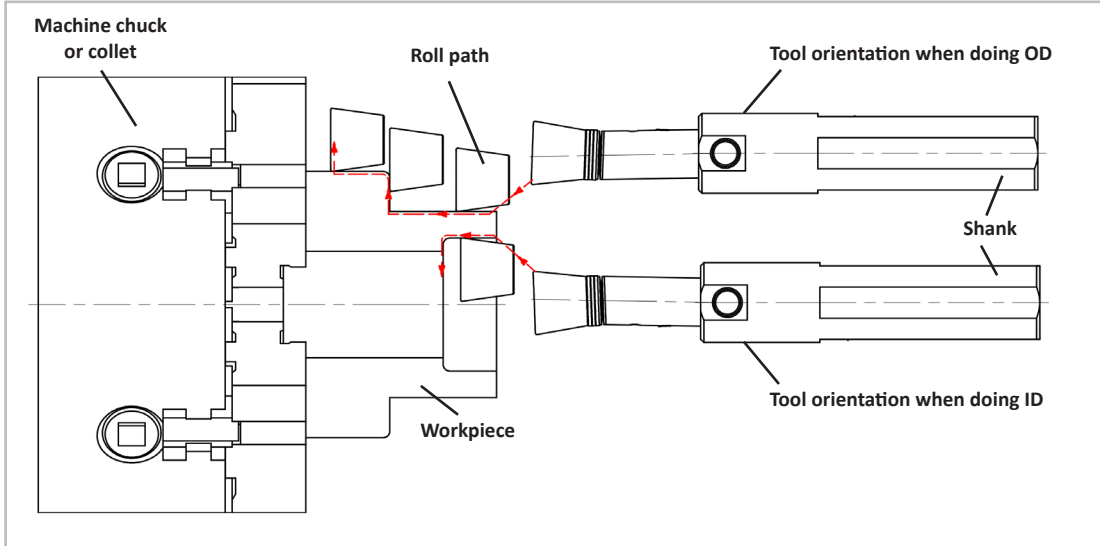

Operating Instructions:

Part Preparations : 80-100 μ -inch Ra (2.0-2.5 μ -m Ra)

Feed Rate : 0.004-0.008 Inch/Rev or IPR, (0.10-0.20 mm/Rev)

Speed : 400-800 SFM, 900 SFM max, (125-245 M/min, 275 M/min max). These speeds are in reference to diameter of part.

Common starting values: 0.006 IPR & 600 SFM, (0.15 mm/rev & 180 M/min)

Contoured, face, angled or tapered surfaces may require slower feedrates; test with $\frac{1}{2}$ the feedrate as used on the OD values.

NOTE: Please run a safe speed for your lathe and set up! It is okay to use less speed than the minimum shown. Consult us for any questions about operating parameters.

Coolant Required – Use water soluble 6% min concentration (8-10% is ideal) or straight cutting oil.

Use included lube fitting to ensure bearings in the roll are sufficiently greased at all times. Bearing manufacturer recommends an NLGI #1 or #2 multi-purpose grease.

Grease tool with the zerk fitting in place. Remove and replace with set screw during use.

The shank will slide into the machine's tool pocket, allowing the tool to project for part clearance. Ensure that the centerline of the roll is on the centerline of the part.

Spring Load:

The Elliott inside surface style burnishing tool has two series of springs for bi-directional spring loading.

One series of springs (Spring Load B), located in the shank, allows the entire head assembly to deflect when the carbide roll is pushed against a surface. A second spring (Spring Load A) is located directly behind the carbide roll. These springs allow for deflection of the carbide roll when the tool is fed directly into a face surface or shoulder.

Tool Setting (ID and OD Surfaces):

Before the tool can be operated, it must be determined how much spring deflection is required and the proper feed rate.

Softer materials such as non-ferrous metals and soft steels should not require a lot of deflection (tool pressure) to burnish properly whereas harder steels and cast irons may require much more deflection (tool pressure).

Initial Set Up:

Spring deflection should be determined first. Bring the carbide roll in contact with the workpiece. Deflect accordingly: for softer materials, use .025" (0.64mm) per side deflection. For harder materials, use 0.075" per side deflection (tool pressure).

Immediately upon deflection, feed the tool across the surface at initial starting values. Check finish to determine if acceptable.

Due to the design of the tool, there is approximately 33 pounds (15 kg) more force when using the Alternate Method of setting the pre-load using the set screw if more pressure is required. See next page for setting method.

If the finish is not smooth enough there are two adjustments:

1) Increase the spring deflection (Spring Load B) between tool & part. When increasing the deflection, use 0.025" (0.64 mm) increments each time. NOTE: at max tool deflection of 0.120" (5.1 mm), there will be almost 90 pounds (41 kg) of force against the part. Use caution when applying this much pressure to keep from pushing the part from the holding device.

OR

2) Decrease feedrate by 0.001" IPR (0.025 mm/rev) increments. If the surface starts getting too rough or starts flaking, back off deflection (tool pressure).

NOTE: After making adjustments to deflection (tool pressure) or feedrate, do not burnish over the same area more than two times or the material may flake due to too much tool pressure.

Alternate method for tool pressure setting (such as O-ring grooves, keyways, snap ring grooves or to feed on and off part):

Before this method can be used, the proper deflection (tool pressure) must first be determined by the **Intial Set Up** method on an area without the interruptions. Once this value is obtained, locate the set screw in the shank of the tool holder.

From the factory, the set screw has been screwed in just far enough to touch the spring, eliminating any slack in the assembly.

****For OD work, orient tool for proper spring deflection.****

Using a 1/8" (0.125") hex wrench, turn the set screw 1/2 turn clockwise to advance the screw approximately 0.018" (0.45 mm). Continue to tighten the screw in until you reach the amount of deflection you determined in **Initial Set Up**. Now, use only approximately 0.005-0.008" (0.13-0.20 mm) worth of deflection to burnish the part and you will have the same tool pressure as in the **Initial Set Up** process.

Tool Setting (shoulder or face surfaces):

Determination of spring deflection (Spring Load A) for burnishing of face or shoulder surfaces is made by feeding the tool forward until the carbide roll contacts the work surface. After the initial contact, continue forward approximately 0.005"-0.010" (0.13-0.25mm). This will cause a like amount of spring deflection. Immediately, upon 0.005"-0.010" (0.13-0.25mm) spring deflection, feed the tool across the surface with the carbide roll leading at the point of contact at initial starting value feedrate.

Check the surface finish to determine if acceptable. If the finish is unacceptable, increase the spring deflection an additional 0.002-0.003" (0.05-0.07 mm), or reduce the feedrate. Again, check surface finish to determine if acceptable. Be sure not to exceed the maximum deflection allowed by the tool (approximately 0.025" max [0.64mm]). There is no way to preload the spring in shoulder burnishing to reduce the deflection amount. Use caution to allow enough room from when the carbide roll exits the face of the part to avoid possible collision with the chuck or machine as the roll will move forward releasing the spring pressure.

****If tool is going to be used for facing operations only, please contact factory for alternative tool set up.****

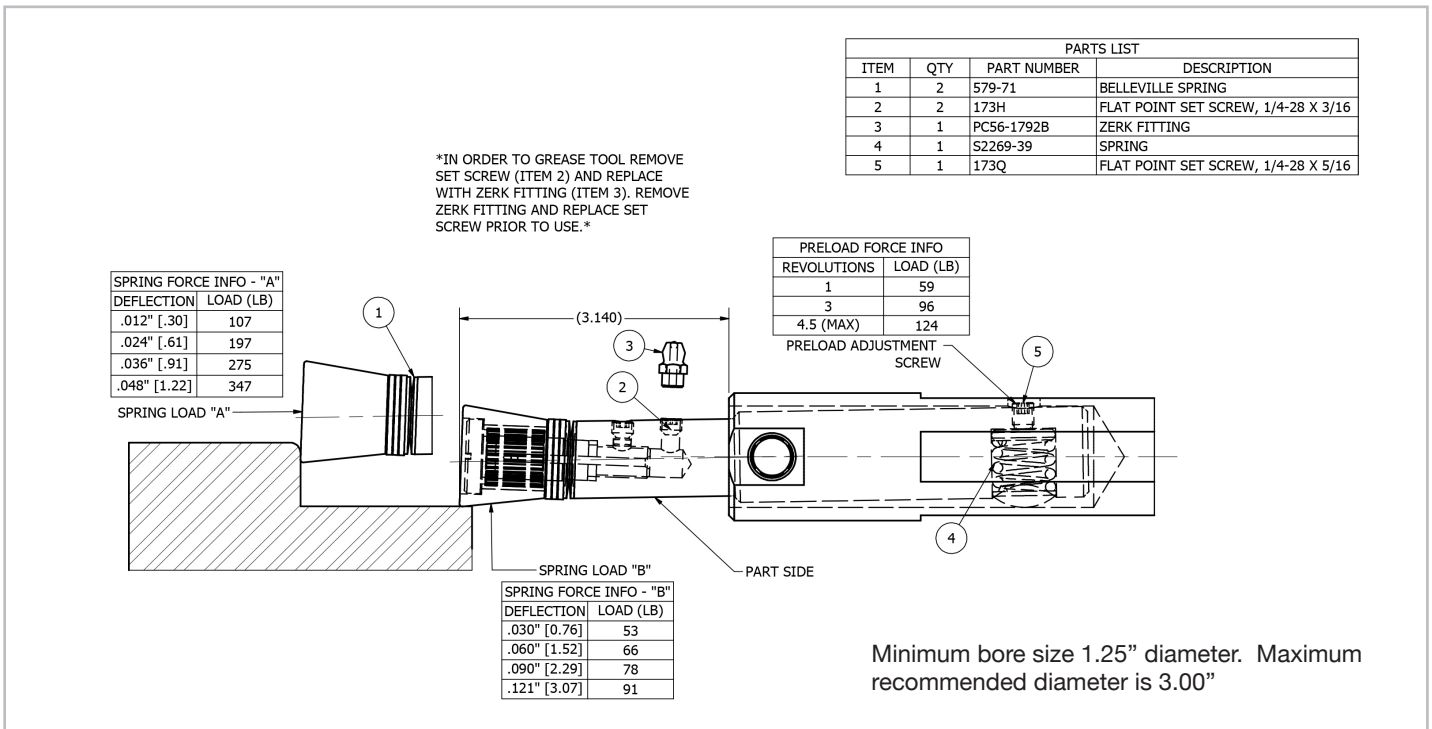

For additional technical support:

1-800-332-0447
 sales@elliott-tool.com
 www.elliott-tool.com

ID/OD CARBIDE ROLL BORING BAR STYLE BURNISHING TOOL

INSTALLATION AND OPERATING INSTRUCTIONS

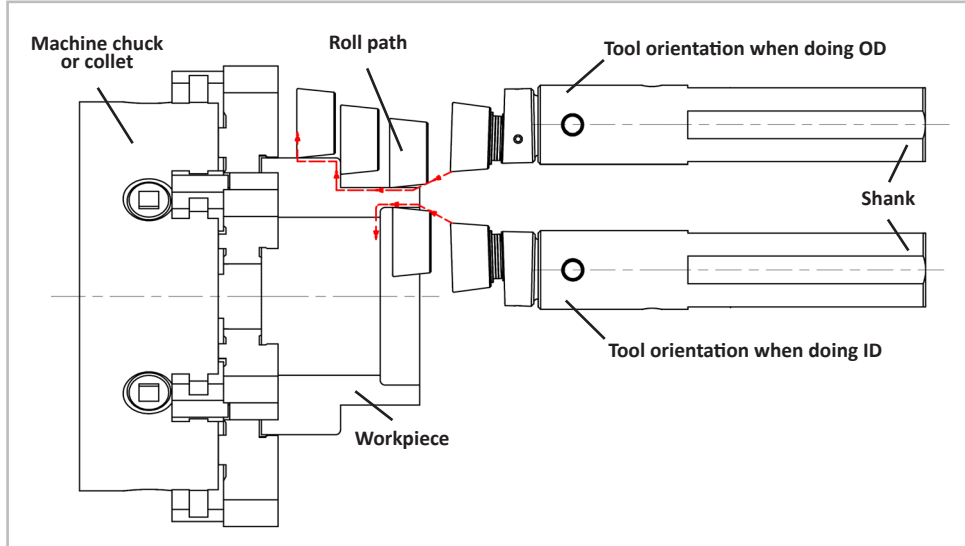

Operating Instructions:

Part Preparations : 80-100 μ -inch Ra (2.0-2.5 μ -m Ra)

Feed Rate : 0.004-0.008 Inch/Rev or IPR, (0.10-0.20 mm/Rev)

Speed : 400-800 SFM, 900 SFM max, (125-245 M/min, 365 M/min max). These speeds are in reference to diameter of part.

Common starting values: 0.006 IPR & 600 SFM, (0.15 mm/rev & 180 M/min)

Contoured, face, angled or tapered surfaces may require slower feedrates; test with $\frac{1}{2}$ the feedrate as used on the OD values.

NOTE: Please run a safe speed for your lathe and set up! It is okay to use less speed than the minimum shown. Consult us for any questions about operating parameters.

Coolant Required – Use water soluble 6% min concentration (8-10% is ideal) or straight cutting oil.

Use included lube fitting to ensure bearings in the roll are sufficiently greased at all times. Bearing manufacturer recommends an NLGI #1 or #2 multi-purpose grease.

Grease tool with the zerk fitting in place. Remove and replace with set screw during use.

The shank will slide into the machine's tool pocket, allowing the tool to project for part clearance. Ensure that the centerline of the roll is on the centerline of the part.

Spring Load:

The Elliott inside surface style burnishing tool has two series of springs for bi-directional spring loading.

One series of springs (Spring Load B), located in the shank, allows the entire head assembly to deflect when the carbide roll is pushed against a surface. A second spring (Spring Load A) is located directly behind the carbide roll. These springs allow for deflection of the carbide roll when the tool is fed directly into a face surface or shoulder.

Tool Setting (ID and OD Surfaces):

Before the tool can be operated, it must be determined how much spring deflection is required and the proper feed rate.

Softer materials such as non-ferrous metals and soft steels should not require a lot of deflection (tool pressure) to burnish properly whereas harder steels and cast irons may require much more deflection (tool pressure).

Initial Set Up:

Spring deflection should be determined first. Bring the carbide roll in contact with the workpiece. Deflect accordingly: for softer materials, use .025" (0.64mm) per side deflection. For harder materials, use 0.075" per side deflection (tool pressure).

Immediately upon deflection, feed the tool across the surface at initial starting values. Check finish to determine if acceptable.

If the finish is not smooth enough there are two adjustments:

1) Increase the spring deflection (Spring Load B) between tool & part. When increasing the deflection, use 0.025" (0.64 mm) increments each time. NOTE: at max tool deflection of 0.135" (3.4 mm), there will be almost 189 pounds (86 kg) of force against the part. Use caution when applying this much pressure to keep from pushing the part from the holding device.

OR

2) Decrease feedrate by 0.001" IPR (0.025 mm/rev) increments. If the surface starts getting too rough or starts flaking, back off deflection (tool pressure).

NOTE: After making adjustments to deflection (tool pressure) or feedrate, do not burnish over the same area more than two times or the material may flake due to too much tool pressure.

Alternate method for tool pressure setting (such as O-ring grooves, keyways, snap ring grooves or to feed on and off part):

Before this method can be used, the proper deflection (tool pressure) must first be determined by the **Initial Set Up** method on an area without the interruptions. Once this value is obtained, locate the set screw in the shank of the tool holder.

From the factory, the set screw has been screwed in just far enough to touch the spring, eliminating any slack in the assembly.

****For OD work, orient tool for proper spring deflection.****

Using a 5/32" (0.156") hex wrench, turn the set screw 1/2 turn clockwise to advance the screw approximately 0.027" (0.71 mm). Continue to tighten the screw in until you reach the amount of deflection you determined in **Initial Set Up**. Now, use only approximately 0.005-0.008" (0.13-0.20 mm) worth of deflection to burnish the part and you will have the same tool pressure as in the **Initial Set Up** process.

Tool Setting (shoulder or face surfaces):

Determination of spring deflection (Spring Load A) for burnishing of face or shoulder surfaces is made by feeding the tool forward until the carbide roll contacts the work surface. After the initial contact, continue forward approximately 0.005"-0.010" (0.13-0.25mm). This will cause a like amount of spring deflection. Immediately, upon 0.005"-0.010" (0.13-0.25mm) spring deflection, feed the tool across the surface with the carbide roll leading at the point of contact at initial starting value feedrate.

Check the surface finish to determine if acceptable. If the finish is unacceptable, increase the spring deflection an additional 0.002-0.003" (0.05-0.07 mm), or reduce the feedrate. Again, check surface finish to determine if acceptable. Be sure not to exceed the maximum deflection allowed by the tool (approximately 0.025" max [0.64mm]). There is no way to preload the spring in shoulder burnishing to reduce the deflection amount. Use caution to allow enough room from when the carbide roll exits the face of the part to avoid possible collision with the chuck or machine as the roll will move forward releasing the spring pressure.

****If tool is going to be used for facing operations only, please contact factory for alternative tool set up.****

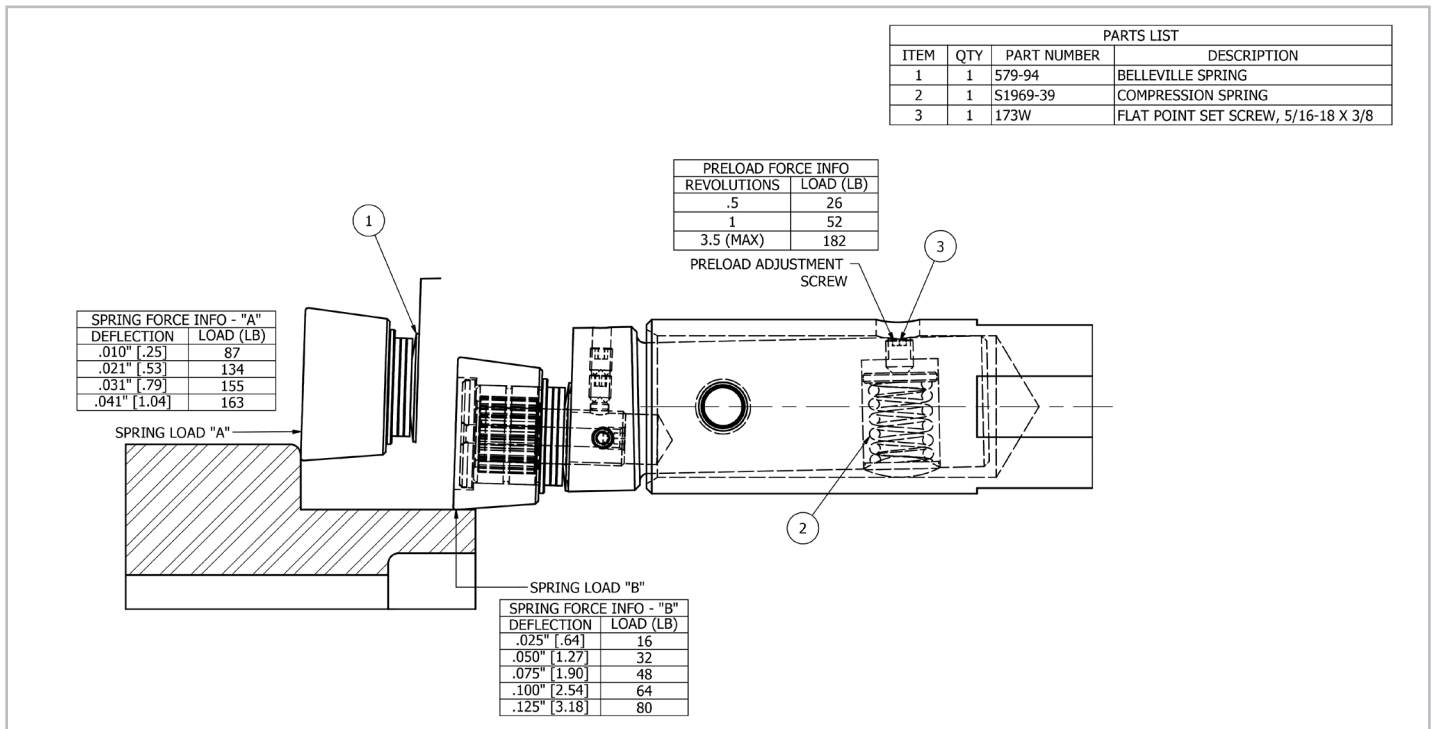

For additional technical support:

1-800-332-0447
 sales@elliott-tool.com
 www.elliott-tool.com