

0820AR Roto-Jet I™ Cleaning System

(Supersedes Models 0800, 0800R, 0820, and 0820R)



Tube & Pipe Cleaners ◦ Tube Testers ◦ Tube Plugs ◦ Tube Removal ◦ Tube Installation

Operating and Maintenance Instructions

Table Of Contents

Introduction	4
Safety	5
Operation.....	8
Operating Position (Diagram A)	9
Drive Coupling (Diagram B)	11
Electrical	14
Plug Grounding (Diagram C & D).....	15
Schematic (Diagram E).....	17
Maintenance.....	18
Technical Data	19
Trouble Shooting Guide.....	21
Records	24 & 25
Parts List 0820AR.....	28
Flexshaft Repair	30

INTRODUCTION

Thank you for purchasing this Elliott product. More than 100 years of experience have been employed in the design and manufacture of this control, representing the highest standard of quality, value and durability. Elliott tools have proven themselves in thousands of hours of trouble free field operation.

If this is your first Elliott purchase, welcome to our company; our products are our ambassadors. If this is a repeat purchase, you can rest assured that the same value you have received in the past will continue with all of your purchases, now and in the future.

The Elliott Roto-Jet I has been designed for expanding tubes in the following types of equipment:

Heat Exchangers

Condensers

Chillers

If you have any questions regarding this product, manual or operating instructions, please call Elliott at +1 800 332 0447 toll free (USA only) or +1 937 253 6133, or fax us at +1 937 253 9189 for immediate service.

SAFETY

Read and save all instructions. Before use, be sure everyone using this machine reads and understands this manual, as well as any labels packaged with or attached to the machine.



WARNING

When using electric equipment, always follow basic safety precautions to reduce the risk of fire, electric shock and personal injury.



WARNING

To reduce the risk of injury, always unplug your machine before performing any maintenance. Never disassemble the machine or try to do any wiring on the electrical system. Contact Elliott for all repairs.

1. Know Your Elliott Roto-Jet I™. Read this manual carefully to learn your tool's applications and limitations, as well as potential hazards, associated with this type of equipment.
2. Ground Your Elliott Roto-Jet I™. Always use properly grounded electrical outlets, and if using an extension cord, make sure that it is of the proper size for the electrical load and it is equipped with a ground wire and ground plug. See "Electrical" section for further information.
3. Avoid Dangerous Environments. Do not use your Elliott machine around or in the presence of explosive atmospheres (gaseous fumes, dust or flammable materials). Remove materials or debris that may be ignited by sparks.
4. Keep Work Area Clean and Well Lighted. Cluttered, dark work areas invite accidents.
5. Dress Properly. Do not wear loose clothing or jewelry. Wear a protective hair covering to contain long hair. It is recommended that the operator wear safety glasses with side shields or a full face shield eye protection. Gloves and water repellant, nonskid footwear are also recommended. Keep hands and gloves away from moving parts.
6. Use Safety Equipment. Everyone in the work area should wear safety goggles or glasses with side shields complying with current safety standards. Wear hearing protection during extended use, respirator for a confined space and a dust mask for dusty operations. Hard hats, face shields, safety shoes, respirators, etc. should be used when specified or necessary. Keep a fire extinguisher nearby.
7. Keep Bystanders Away. Bystanders should be kept at a safe distance from the work area to avoid distracting the operator and contacting the flexshifting, machine or extension cord. Only the operator of the machine should engage the foot switch control. NEVER PLACE A WEIGHTED OBJECT ON THE FOOT SWITCH TO PRODUCE CONTINUOUS OPERATION OF THE MACHINE.
8. Protect Others in the Work Area from debris such as water exhaust and water spray. Provide barriers or shields as needed.

SAFETY (CONT.)

9. Use the Right Cleaning Device. Do not use a cleaning device or attachment to do a job for which it is not recommended. Refer to the Elliott Tube Tool catalog for all optional equipment. Do not alter the machine or cleaning device, this will void the warranty on the product.
10. Use Proper Accessories. Use Elliott accessories only. Be sure accessories are properly installed and maintained. Do not defeat a guard or other safety device when installing an accessory or attachment.
11. Check for Damaged Parts. Inspect guards and other parts before use. Check for misalignment, binding of moving parts, improper mounting, broken parts or any other conditions that may affect operation. If abnormal noise or vibration occurs, turn the machine off immediately and have the problem corrected before further use. Do not use a damaged machine. Tag damaged machines “Do Not Use” until repaired. A guard or other damaged part should be properly repaired or replaced by an Elliott service facility. For all repairs, insist on only identical replacement parts.
12. Remove All Wrenches. Check that all accessory wrenches are removed from the system before turning it on.
13. Guard Against Electric Shock. Hold the flexshaft by the insulated nonmetal casing surfaces. Inspect and test the Ground Fault Circuit Interrupter (GFCI) prior to each new use of the machine to ensure its proper operation. For more information refer to the “Electrical” section.
14. Avoid Accidental Starting. Be sure your machine is turned off before plugging it in. Do not use a machine if the foot switch control does not turn the machine on and off. NEVER USE ANY OBJECT TO HOLD THE FOOT SWITCH IN THE “ON” POSITION.
15. Do Not Force the Flexshaft. Your Elliott Roto-Jet™ will perform best at the rate for which it was designed. Excessive force only causes operator fatigue, increased flexshaft wear, shaft or break away coupling failure.
16. Keep Hands Away from All Moving Parts.
17. Do Not Abuse Cord. Never carry your machine or foot switch by its cord. Never unplug the machine by yanking the cord from the outlet. Pull the plug rather than the cord to reduce the risk of damage. Keep the cord away from heat, oil, sharp objects, cutting edges and moving parts.
18. Do Not Overreach - Maintain Control. Keep proper footing and balance at all times.
19. Stay Alert. Watch what you are doing, and use common sense. DO NOT use a machine when you are tired, distracted or under the influence of drugs, alcohol or any medication causing decreased control.
20. Unplug Machine when it is not in use, before changing accessories or performing recommended maintenance.
21. Maintain Machine Carefully. Keep handles dry, clean and free from oil and grease. Follow instructions for lubricating and changing accessories. For more information see “Maintenance” section. Periodically inspect the machine cord and extension cords for damage. Have damaged parts repaired or replaced by an Elliott service facility.
22. Store Idle Machines. When not in use, store your machine in a dry, heated, secured place. For more information see “Maintenance” section.

SAFETY (CONT.)

23. Maintain Labels and Nameplates. These carry important information and will assist you in ordering spare and replacement parts. If unreadable or missing, contact an Elliott service facility for a replacement.
24. Stop the Machine Immediately if the Flexshaft Starts to Coil. Flexshaft damage will occur if flexshaft is operated in a coiled position.
25. Use the Proper Flexshaft to fit the tubes to be cleaned. Never use a flexshaft that is too small or too short. Flexshaft failure will result if too great a resistance is placed on the flexshaft. Refer to the chart below for sizing information. (See Fig. 1 and 2)

Wet Shafts (Fig.1)				
Prefix Part Number	Casing Outside Diameter		Tube Inside Diameter	
	inch	mm	inch	mm
0511*(xx)	.250	6	5/16 - 3/8	8 - 10
0512*(xx)	.375	10	7/16 - 1/2	11 - 13
0513*(xx)	.500	13	9/16 - 1	14 - 25
0514A*(xx)	.625	16	3/4 - 1-1/2	19 - 38
0514*(xx)	.750	19	1 - 2	25 - 50
0515*(xx)	1.000	25	2 and over	50 and over

*Length of shaft in feet completes the part number.
 (Available in standard lengths of 16', 25', 33', and 49'. Consult factory for additional lengths.)

Dry Shafts (Fig.2)				
Prefix Part Number	Casing Outside Diameter		Tube Inside Diameter	
	inch	mm	inch	mm
0534*(xx)	7/8	22	1 and over	25 and over

*Length of shaft in feet completes the part number.
 (Available in standard lengths of 25', 35', and 50'. Consult factory for additional lengths.)

OPERATION

Correct Machine Position and Operation is critical to getting the job done quickly and efficiently. This can be accomplished by the following these steps:

Examine the tubes to be cleaned and measure the internal diameter (Elliott Tube Gage is recommended) and length of the tubes. If the tube ends are expanded, then make a note of the smallest internal diameter. Record these measurements on the charts provided on page 24 and 25 of this manual. You will need these measurements to select the proper size flexshaft and cleaning attachments.

TOOL TIP

Always select a smaller size of cleaning device for heavy tube deposits. With the exception of the Elliott Turbo Brush, never use a brush or cleaning device larger than the internal diameter of the tubes.

Roll or hand carry the machine to the location where the cleaning will take place.

Position the machine at a right angle to the tube sheet or cleaning area. This will keep the flexshaft at the proper radius. **NEVER OPERATE THE MACHINE IN THE VERTICAL POSITION.** (See Diagram A page 9).

Remove pin from handle bracket and lower handle on the machine to its lowest setting and replace the handle pin.

Lower the machine to the horizontal position, resting the end of the handle on the floor.

Open the foot switch storage compartment and remove the foot switch, "O" ring, and rubber hose washer.

Place the rubber hose washer in the water hose connection of the machine. This is a one time operation. The rubber washer can remain in this connection and does not require removal after use.

Connect a standard garden hose to the 3/4" water hose connection of the machine. The machine is designed for "Municipal" water pressure only, Max 100 psi (6.89 Bar-Metric). **DO NOT** connect the water connection to a "High Pressure" source. Water is important to the cleaning process as it flushes away deposits cleaned from the tube and helps to lubricate and cool the flexshaft.

Position the "O" ring in the recess of the flexshaft connection manifold.

DIAGRAM A

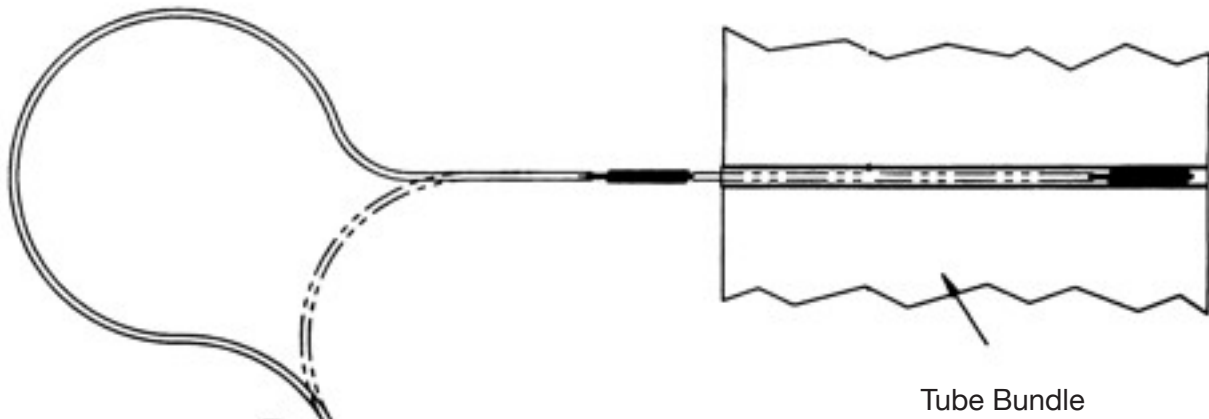

TOP VIEW

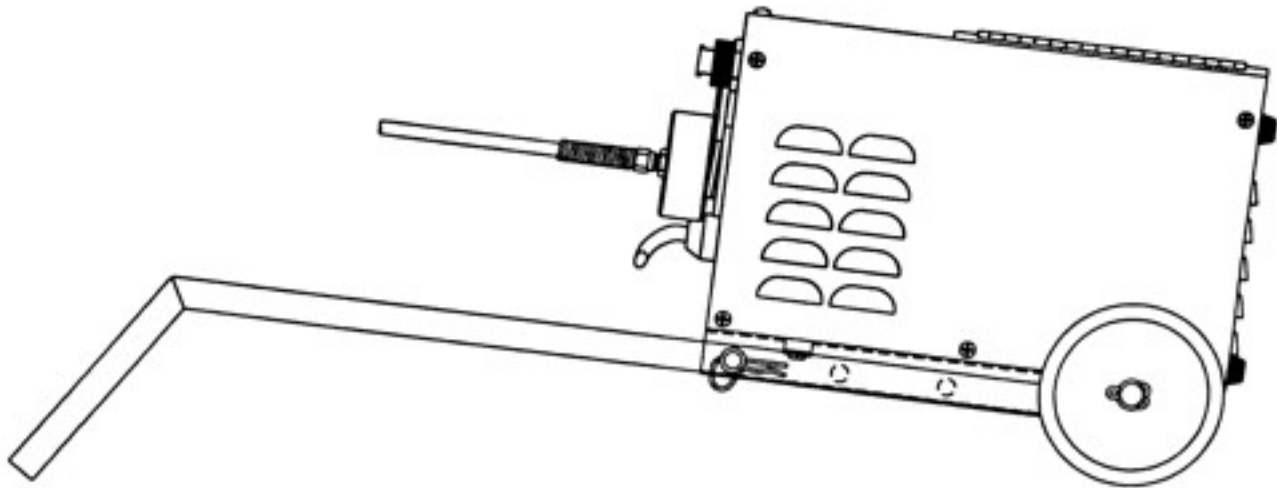
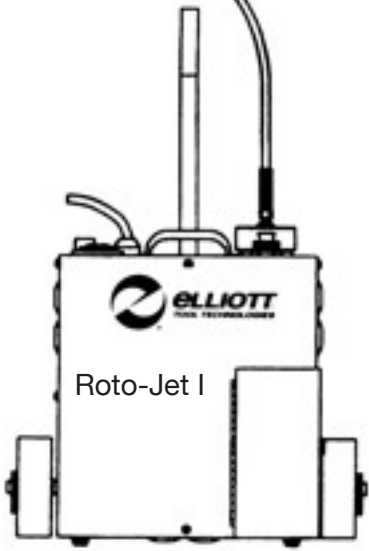

CORRECT OPERATING POSITION

OPERATION (CONT.)

Prepare the flexshaft by loosening the four (4) set screws located in the brass locking sleeve using a 3/32" Allen wrench. Thread the breakaway or solid square drive into the coupling adapter that is swaged on the core of the flexshaft. Position the brass locking sleeve equally over the coupling adapter and the breakaway or solid square drive. Firmly tighten the four (4) Allen set screws. (See Diagram B page 11)

Insert the square drive into the manifold of the machine. Rotate the flexshaft by hand to properly seat the square drive of the flexshaft into the manifold. Thread the brass manifold cap onto the manifold of the machine and firmly hand tighten.

Attach the chosen cleaning device to the tool coupling swaged to the core of the flexshaft at the opposite end from the manifold connection and firmly tighten the device.

To prevent the cleaning device from unthreading when using the reverse mode of the machine, place a 1/4" lock washer between the tool coupling and the cleaning device and firmly tighten the connection.

Plug the machine into the appropriate electrical source. For more information see "Electrical" section.

Turn on the water supply.

Layout the flexshaft as straight as possible. DO NOT start the machine with the flexshaft in a coiled position.

Depress the foot switch. The electric motor will operate and drive the flexshaft, which will rotate the cleaning device. At the same time, water will pass through the machine and out the end of the flexshaft casing near the cleaning device. Remove your foot from the foot switch and both the water and rotation of the shaft will stop. Restart the machine and observe the water output from the end of the flexshaft casing. A constant stream of water should be discharged from the casing as the core rotates. If no water is discharged from the flexshaft, check the hose and hose connection for any "kinks" that would restrict water flow. If there is no rotation of the flexshaft, check the Ground Fault Circuit Interrupter (GFCI) reset button. For more information see "Electrical" section. Depress the foot switch again and observe the water flow from the end of the flexshaft. If no water is discharged, from the flexshafting, discontinue use of the machine and contact an Elliott service facility.

Let machine completely stop rotation before depressing the reversing pedal. Reverse rotation and water flow will begin when the reverse pedal is depressed and will stop when released.

DIAGRAM B

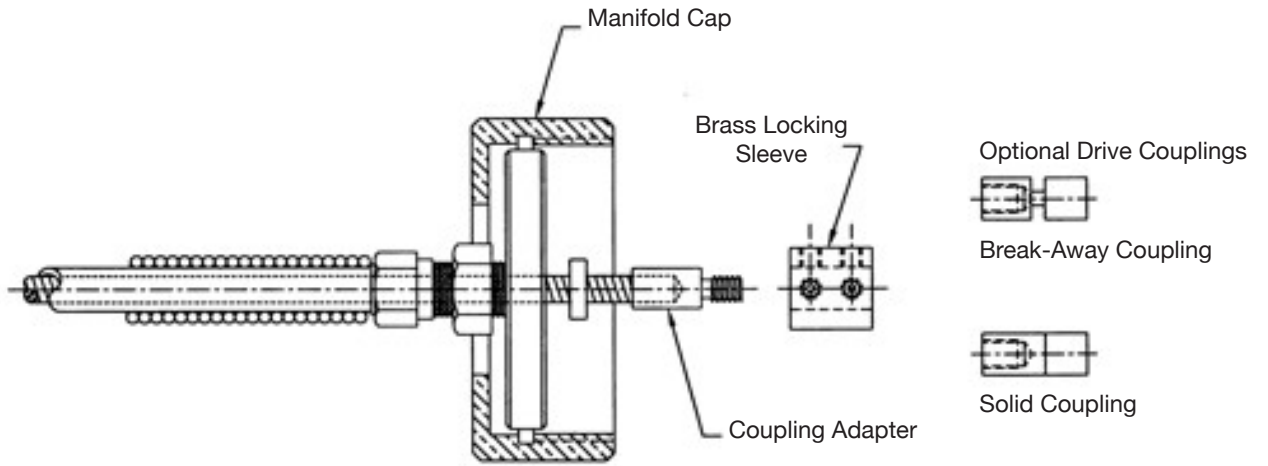

OPERATION (CONT.)

The machine is now ready to operate.

TOOL TIP

Operate the flexshaft as straight as possible to minimize any sharp radius bends. This applies to both brush insertion and maximum cleaning length. Operating the flexshaft in a constant sharp radius will flex fatigue the wires in the core reducing its strength. Allowing the cleaning device to exit the tube while rotating can cause premature shaft failure in the tool coupling area. Never exit the tube with the tube cleaning device in operation. For more information see “Technical” section.



WARNING

This machine drives high speed, rotating cleaning devices. It is recommended that the operator wear safety glasses with side shields or full face shield eye protection, gloves and water repellent, nonskid foot wear. Avoid contact with objects other than the tube when the machine is in operation.

TOOL TIP

Measure the length of the tubes being cleaned from the tube sheet to the tube sheet at the opposite end. Transfer this measurement to the flexshaft from the END of the cleaning device up the casing toward the machine. Mark the end of the measurement on the casing by wrapping the point with electrical tape. This will enable you to feed the flexshaft through the tube and stop the cleaning device before exiting the tube on the opposite end. For Model 0820AR users, stop forward rotation of the machine when the tape mark reaches the tube sheet and start reverse rotation to back the cleaning device out of the tube.

Hold the end of the flexshaft with your hand about 12” (304.8mm) back from the cleaning device. Insert the cleaning device just inside the tube to be cleaned and hold the flexshaft away from your body. Depress the foot switch and start to feed the flexshaft down the tube.

It is important that the flexshaft not be forced down the tube. If you meet resistance, proceed at a slower pace or refit the flexshaft with a smaller cleaning device. Should the flexshaft meet too much resistance it will begin to coil. **DO NOT ALLOW THE FLEXSHAFT TO COIL.** Coiling of the flexshaft could cause binding within the casing and shear the core material. If a blockage is encountered, and the shafting begins to coil, immediately stop feeding the shafting into the tube and start drawing the shafting back until coiling stops. Then proceed to slowly feed the flexshafting into the tube, being sure to draw the shafting back when blockage is encountered and coiling begins. Follow this procedure until the cleaning device removes the blockage.

OPERATION (CONT.)

TOOL TIP

Start to clean the tube bundle from the top of the unit to the bottom. Clean the bundle one row at a time, marking with soapstone, each row of tubes that have been cleaned.

After cleaning has been completed, unplug the machine from the electrical source.

Return the foot switch to the storage compartment.

Remove the flexshaft by rotating the manifold cap counter-clockwise from the manifold then pull the flexshaft free from the drive coupling.

Drain any excess water from the flexshaft.

Remove the “O” ring from the manifold and place it in the plastic bag and return the bag to the storage compartment and close the door.

Remove the water hose from the machine.

Return the machine to the upright position.

For handle and axle assembly removal from the machine; remove the two hex head cap screws from the axle with a 7/16” wrench or socket and remove the axle assembly.

Remove the two hex head cap screws from the handle assembly using a 7/16” wrench or socket and remove handle assembly.

To replace handle and axle assemblies, reverse the order for disassembly. Note that the axle cut out is positioned over the handle assembly tab.

ELECTRICAL

Your Elliott Roto-Jet™ has been designed to require a grounded electrical receptacle, of 240 volts, single phase, 10 amps, A.C. current. Serious damage to the unit can occur within the electrical components if the electrical supply, voltage and amperage rating does not meet this requirement. An electrical diagram is supplied with this manual as a reference (page 15). Only a qualified electrician should use the electrical diagram to perform any maintenance or repairs.

This machine requires electrical grounding. A grounding plug must be used with this machine. The plug must be connected to a properly grounded outlet. If the machine should electrically malfunction or breakdown, grounding provides a low resistance path to carry electricity away from the user, reducing the risk of electrical shock.

The grounding device in the plug is connected through the green wire inside the cord to the grounding system in the machine. The green wire in the cord must be the only wire connected to the tool's grounding system and must never be attached to an electrically "live" terminal.

Your machine must be plugged into an appropriate outlet, properly installed and grounded in accordance with all codes and ordinances. If in doubt of proper grounding, contact a qualified electrician. The Canadian Electrical Code prohibits the use of temporary adapters.



WARNING

Improperly connecting the grounding wire can result in the risk of electric shock. Check with a qualified electrician if you are in doubt as to whether the outlet is properly grounded. Do Not use the machine if the cord or plug is damaged. If damaged, have it repaired by an Elliott service facility before use.

ELECTRICAL (CONT.)

Extension cords may be used with the machine, providing the cord is equipped with three wires, 12 gauge in size, with ground plugs and not longer than 50' in length. Using extension cords with inadequately sized wire causes a serious drop in voltage resulting in possible machine damage. The smaller the gauge number of the wire, the greater the capacity of the cord. For example, a 12 gauge cord can carry a higher current than a 14 gauge cord.

- Be sure your extension cord is properly wired and in good electrical condition. Always replace a damaged extension cord or have it repaired by a qualified person before using it.
- Protect your extension cords from sharp objects and excessive heat.

DIAGRAM C

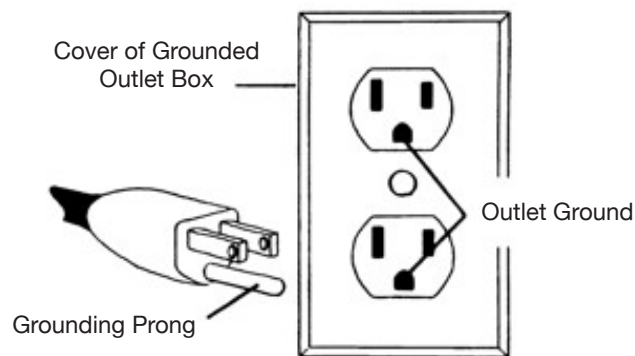
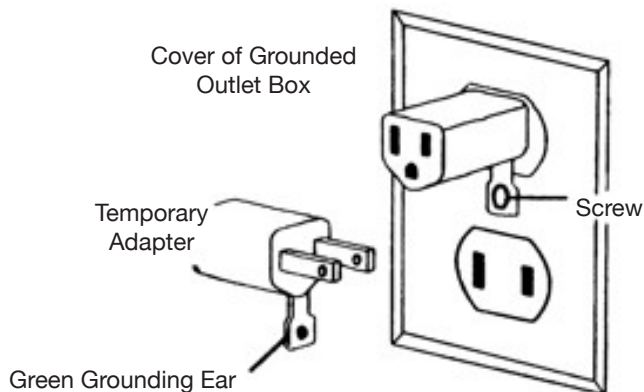

DIAGRAM D



ELECTRICAL (CONT.)

Ground Fault Circuit Interrupter (GFCI). Your Elliott Roto-Jet I™ is equipped with a Ground Fault Circuit Interrupter on the power cord set. You should “test” the GFCI receptacle prior to each new operating use. Testing of the GFCI receptacle is as follows:

- Plug machine into proper electrical outlet.
- Locate the ground fault circuit interrupter (GFCI) found on the power cord.
- Locate and push the “test” button, with your finger, on the Ground Fault Circuit Interrupter. Never use any other device to push the test button.
- An audible “click” should be heard when the button is depressed.
- Engage the foot switch of the machine. The machine Should Not operate.
- Release the foot switch of the machine, locate and push the “reset” button, with your finger.
- Engage the foot switch of the machine. The machine should operate normally.

If the machine should fail this testing process, contact an Elliott service facility immediately. Do Not attempt to use the machine in this condition. An electric shock could occur if there is a malfunction of the GFCI circuit.

DIAGRAM C

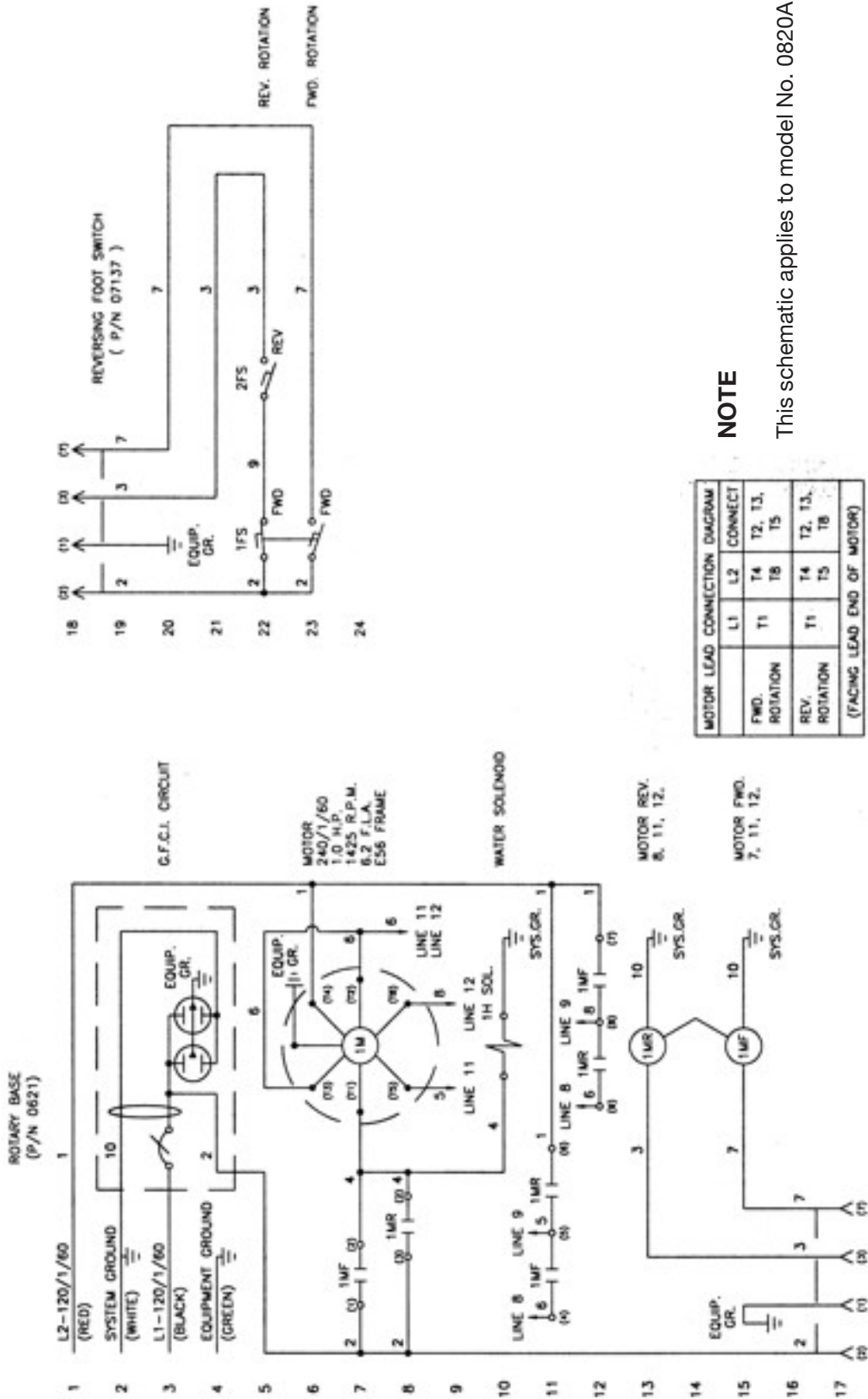

NOTE

This schematic applies to model No. 0820AR.

MOTOR LEAD CONNECTION DIAGRAM	
L1	L2 CONNECT
FWD. ROTATION	T4 T2, T3, T5
REV. ROTATION	T4 T2, T3, T5

(FACING LEAD END OF MOTOR)

MAINTENANCE



WARNING

To reduce the risk of injury, always unplug your machine before performing any maintenance. Never disassemble the machine or try to do any rewiring on the machine's electrical system. Contact Elliott for all repairs.

Keep your Roto-Jet I™ in good repair by adopting a regular maintenance program. Before each use, examine the general condition of your machine. Inspect connections, foot switch, machine cord set and extension cords for damage. Check for loose screws, misalignment, binding of moving parts, improper mounting, split flexshaft casing, broken parts or any other condition that may affect its safe operation. If abnormal noise or vibration occurs, turn the machine off immediately and have the problem corrected before further use. For more information see “Trouble Shooting” section. **DO NOT USE A DAMAGED MACHINE.** Tag damaged machines “DO NOT USE” until repaired.

Under normal conditions lubrication of the machine between uses is not necessary, unless the machine has been operated “dry”. Should you wish to use the machine dry, the manifold drive shaft must be lubricated with a few drops of oil. Position the machine vertically, use a standard long spout oil can to place the oil behind the brass square drive coupling. Using the machine dry after it has been used for wet operation, could damage the seals and bearings, which may require replacement if not lubricated..

Clean dust and debris from vents. Keep the machine handles clean, dry and free of oil or grease.

Your machine has been finished with a two-part, epoxy, paint coating that is very durable and should last the life of the machine. Use only mild soap and a damp cloth to clean your machine. Certain cleaning solvents may be harmful to the painted surfaces. Never use flammable or combustible solvents around machines.

After each use, drain all water from the flexshaft outer casing. Store the flexshaft by laying it down, in a large diameter coil, in a dry, secured area.

After every cleaning season or 12 months remove the machine cover and check the “V” belt for cracking and wear. Replace the cover and position the machine vertically. Lubricate the manifold drive shaft, behind the female brass square drive coupling with a few drops of oil. An oil can with a standard long spout will be required. Make sure the flexshaft casing is drained of all water. Lubricate the flexshaft with a water soluble lubricant solution diluted to the manufacturers recommendations. An oil can with a standard long spout will be required. Position the spout between the flexshaft core and the casing. Fill and drain the flexshaft from both ends. When finished, store the flexshaft by laying it down, in a large diameter coil, in a dry, secured area. Start the next cleaning season by operating the machine prior to starting a new job. For more information on proper operation see “Operation” section.

TECHNICAL DATA

Horsepower: 1 H. P. Electric Motor

Voltage: 240 Volts, Single Phase, 50/60 Cycles, 5.0 Amps.

G. F. C. I. Trip Threshold: 5 mA

G. F. C. I. Trip Time: 0.025 Seconds Nom. Per UL Std.

Wheel Size: 8" (203.2 mm) Outside Diameter x 2.250" (57.15 mm) Hub Width
x .750" (19.05 mm) Inside Diameter

Overall Size Without Hand Cart: 17" x 15" x 10.5" (431.8 x 381 x 266.7 mm)

Overall Hand Cart Size: 21.5" x 34" x 6" (546.1 x 863.6 x 152.4 mm) Handle Retracted
41" (1041.4 mm) Handle Extended

Unit Weight Without Cart: 67 lbs. (30.39 kg)

Unit Weight With Cart: 72 lbs. (32.66 kg)

The charts below refer to the flexshafts only. Match the prefix numbers to your shafting size.
(See Fig. 3 and 4)

Maximum Torque Ratings For Flexshaft Core Material When Lying Straight

Wet Shafts (Fig.3)		
Prefix Flexshaft Number	Maximum Torque	
	(Inch Pounds)	(Newton-Meters)
0511*(xx)	16	1.8
0512*(xx)	105	11.9
0513*(xx)	210	23.7
0514A*(xx)	295	33.3
0514*(xx)	580	65.5
0515*(xx)	1155	130.5

*Length of shaft in feet completes the part number.
(Available in standard lengths of 16', 25', 33', and 49'. Consult factory for additional lengths.)

Dry Shafts (Fig.4)		
Prefix Flexshaft Number	Maximum Torque	
	(Inch Pounds)	(Newton-Meters)
0534*(xx)	580	65.5

*Length of shaft in feet completes the part number.
(Available in standard lengths of 25', 35', and 50'. Consult factory for additional lengths.)

When the flexshaft is used in a bend or radius configuration, the maximum torque capability of the core is reduced. The following charts demonstrate the effect that bending has on the flexshaft. (See Fig. 5, 6, 7, and 8)

Wet Shafts (Fig.5)								
Flexshaft Prefix No.	Radius 4"	Radius 6"	Radius 8"	Radius 10"	Radius 12"	Radius 15"	Radius 20"	Radius 25"
0511*(xx)	2	3	3	4	4	4	4	4
0512*(xx)	11	14	17	20	22	23	25	26
0513*(xx)	21	25	34	39	42	45	48	52
0514A*(xx)	25	36	47	55	57	59	68	74
0514*(xx)	N/A	53	74	95	107	119	131	140
0515*(xx)	N/A	N/A	105	139	168	200	221	242

Above figures represent Inch Pounds of Torque to Flexshaft Fatigue.

Wet Shafts (Fig.6)								
Flexshaft Prefix No.	Radius 102mm	Radius 152mm	Radius 203mm	Radius 254mm	Radius 305mm	Radius 381mm	Radius 508mm	Radius 635mm
0511*(xx)	0.2	0.3	0.3	0.5	0.5	0.5	0.5	0.5
0512*(xx)	1.2	1.6	1.9	2.3	2.5	2.6	2.8	2.9
0513*(xx)	2.4	2.8	3.8	4.4	4.7	5.1	5.4	5.9
0514A*(xx)	2.8	4.1	5.3	6.2	6.4	6.7	7.7	8.4
0514*(xx)	N/A	6.0	8.4	10.7	12.1	13.4	14.8	15.8
0515*(xx)	N/A	N/A	11.9	15.7	19.0	22.6	25.0	27.3

Above figures represent Newton-Meters of Torque to Flexshaft Fatigue.

*Length of shaft in feet completes the part number.
(Available in standard lengths of 16', 25', 33', and 49'. Consult factory for additional lengths.)

Dry Shafts (Fig.7)								
Flexshaft Prefix No.	Radius 4"	Radius 6"	Radius 8"	Radius 10"	Radius 12"	Radius 15"	Radius 20"	Radius 25"
0534*(xx)	N/A	N/A	N/A	95	107	119	131	140

Above figures represent Inch Pounds of Torque to Flexshaft Fatigue.

Dry Shafts (Fig.8)								
Flexshaft Prefix No.	Radius 102mm	Radius 152mm	Radius 203mm	Radius 254mm	Radius 305mm	Radius 381mm	Radius 508mm	Radius 635mm
0534*(xx)	N/A	N/A	N/A	10.7	12.1	13.4	14.8	15.8

Above figures represent Newton-Meters of Torque to Flexshaft Fatigue.

*Length of shaft in feet completes the part number.
(Available in standard lengths of 25', 35', and 50'. Consult factory for additional lengths.)

TROUBLE SHOOTING GUIDE

Machine will not start when foot switch is depressed.

- Check for proper voltage at electrical source.
- Push the reset button on the GFCI located on the power cord set.
- Check the power cord, foot switch cord and extension cord for cuts or loose connections.

Machine makes a repetitive “clicking or chattering noise” when foot switch is depressed.

- DO NOT CONTINUE TO OPERATE THE MACHINE! Damage to the electrical components will result if the machine is used with this condition.
- Check for proper voltage at electrical source. (See “Electrical” section).
- Check for proper gauge and length of extension cord. (See “Electrical” section).

Machine rotates but no water is flowing from the end of the flexshafting.

- Check the flexshaft and machine connection.
- Check the garden hose entering the machine for kinks or pinch points.
- Check the water supply valve to verify that it is “on” and that water pressure is sufficient.

Water is leaking from the machine.

- Check “O” ring part #P8309-25 in manifold part #07136. Replace if missing or worn.
- Remove the machine cover and verify that the tube from the water supply to the manifold is in place.
- Seals within the manifold are damaged and need to be replaced. Call an Elliott service facility.

Flexshaft stops rotating.

- Remove flexshaft from the machine and check the break-away coupling.
- Check the connection of the flexshaft and the machine, be sure flexshaft manifold cap is secured on manifold.
- Remove the machine cover and check the “V” belt for proper tension.
- Remove the machine cover and check the set screws on the pulley shafts for proper tightness.

Flexshaft breakage near the machine.

- Radius of flexshaft is too sharp. Position machine horizontally and at right angle to the tubes being cleaned. (See “Operation” section)
- Flexshaft is too short for the length of tube being cleaned causing too sharp a radius for proper operation of the flexshaft. Call Elliott to obtain the proper length.

Flexshaft breakage near the cleaning device.

- Flexshaft is allowed to exit the far end of the tube being cleaned causing “whipping” of the flexshaft. Measure and mark flexshaft casing with tape to prevent “over-travel” of flexshafting when cleaning. (See “Operation” section).
- Flexshaft is being forced through a tube blockage. Reduce the rate of feed on the flexshaft and allow cleaning device additional time to clear the blockage. (See “Operation” section).

Flexshaft coils up when cleaning device is inserted into the tube.

- Check the internal diameter of the tube past the expanded portion at the tube opening. Verify the working diameter of the cleaning device being used.
- Reduce the feed rate of the flexshaft and allow more time for the cleaning device to remove deposits.
- Check for internal enhanced (rifled) surface under the deposit layer. Some cleaning devices are not designed to clean this type of surface.
- Check for sharp bends or pinch points in the flexshaft.
- Check for proper water flow through the flexshaft. (See “Operation” section).
-

How to repair broken flexshafts.

-
- • See pages 30 & 31 for use of W900-00.

NOTES



0820AR Parts List

Item	Description	Part Number	Qty.
1	Power Unit Complete less Foot Switch	0821A	
2	Electric Motor - 1 H.P.	06201	1
3	Low Profile 90° Elec. Conduit Elbow	06202	1
4	Female Disconnects, Insulated	06204*	11
5	Spade Connectors, Insulated	06205*	4
6	Female Blade Connector, Insulated	06207*	6
7	Crimp Style Wire Connector	06208*	6
8	3/8" Male Elbow Swivel	06209	2
9	Handle Support Bracket	06012	1
10	Handle	06014	1
11	Clevis Pin	06015	1
12	Axle	06016	1
13	Wheel	06017	2
14	Hairpin Cotter	06018	1
15	Reverse Motor Contactor (220V)	08101-1	1
16	Drive Belt	07104	1
17	Large Pulley (5")	07105	1
18	Small Pulley (2.5")	07106	1
19	Swivel Connector	07107	1
20	Hex. Nipple Reducer	07108	1
21	Anchor Connector	07109	1
22	Solenoid Valve (220V)	07111	1
23	Lock Nut	07112	2
24	Enclosure, Bottom	07116	1
25	Phenolic Insulator Plate	07116-9*	2
26	Receptacle Cover w/ Gasket	08117	1
27	Shaft Drive w/ Socket	07120	1
28	Enclosure, Top	07121	1
29	Electrical Cord w/ G.F.C.I.	07151	1
30	Support Pad	07125	4
32	#14 Awg Electric Wire (Green)	07131-4*	39"
33	#14 Awg Electric Wire (White)	07131-5*	26"
34	#14 Awg Electric Wire (Black)	07131-7*	18"
35	Rubber Washer	07135	1
36	Manifold Assembly	07136	1
37	Electrical Tubing	07151-1	23"
38	Quick Change Adapter	07152	4
39	Strain Relief Connector	07153	1
41	Tubing	04131	7"
43	Hex. Head Cap Screw	130AD	2
44	Hex. Head Cap Screw	130AF	2
45	Spring Pin	P8386-24	2
46	Washer	169T	4
47	Elastic Lock Nut	546C	4
48	Filister Head Machine Screw	544A	4
49	Hex. Head Cap Screw	130BC	4
50	Elastic Lock Nut	546A	4
51	Self-Tapping Filister Head Machine Screw	577-1	12
52	Hex. Washer Head Self-Drilling Screw	584-1	2
53	Hex. Washer Head Self-Drilling Screw	584-2	3
54	Wire Ties	900078P*	4
55	1/2" Conduit Lock Nut	M5631D14*	3
56	Thrust Washer	P1067CA	4
57	"O" - Ring	P8309-25	1
58	Lock Nut	PC76-1000014	1
60	Push-On Retainer	586-4	4
61	Fender Washer	587-1	4
62	Support Rod	07116-10*	1
63	Roto-Jet Accessories Label	04226-1*	1
64	Logo Label	ETTLBL6000A*	2
65	Electric Label	04226-3*	1
66	Roto-Jet Label	04226-5	1
67	Foot Switch Connection Label	04226-8*	1

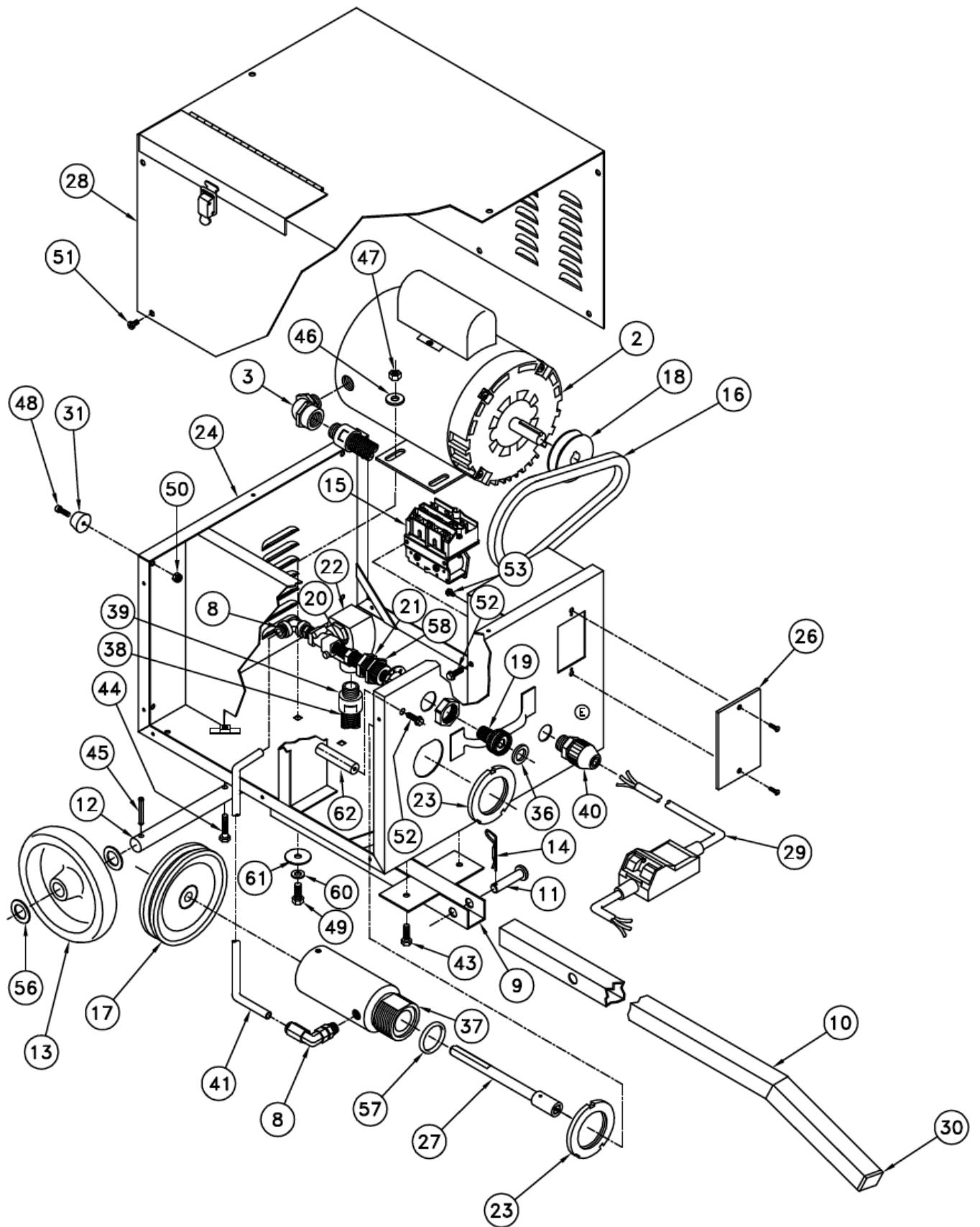

** To convert models 0800R and 0820R to new style receptacle and foot pedal plug, see Tech Manual TM-32.

FLEXSHAFT REPAIR

Flexshaft Repair Instructions

Instructions for Both the Tool and Motor Couplings

Using the Elliott Crimping Block Assembly

Part Number W900-00

1. Cut the outer casing back approximately 1" (25.4mm) for clearance to allow the core to be cleaned up at the break. Grind the end of the core taking care not to overheat the wire strands. Using a hacksaw to square the broken end will cause the wire strands to flex and unwind.
Note: The compression fitting on the motor coupling should not be removed from the casing, if the excess length of casing is trimmed from the tool coupling end of the flexshaft.
2. Slightly bevel the circumference of the core to remove any burrs.
3. Insert the replacement coupling onto the core. Be sure the core is fully engaged to the full drilled length of the coupling.
Note: When replacing the motor coupling, insure that the square washer has been placed onto the core before inserting the motor coupling.
4. Locate the assembly of the core and coupling in the proper hole location of the crimping block. Position the assembly in the crimping block with the core end of the coupling, flush with the side of the block.
5. Insert the drive pin in the proper hole above the coupling to be crimped.
6. Strike the pin with a hammer. Care must be taken with this operation, excessive force will deform the coupling and cause the core to distort and unwind.
7. For flexshaft sizes 0513, 0514 and 0515, rotate the coupling in the crimping block approximately 60° and strike the pin again. Repeat this operation around the coupling. For flexshaft sizes 0511 and 0512, rotate the coupling in the crimping block approximately 120° and strike the pin again. Repeat this operation around the coupling.
8. The coupling is now secure with equally spaced crimping locations holding the core.

Crimp locations
0511 0512
@ 120° intervals

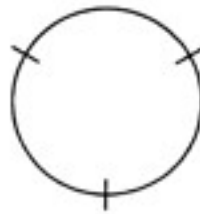

Crimp locations
0513 0514 0515
@ 60° intervals

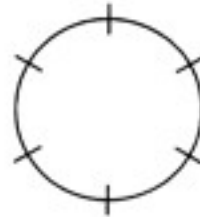

W900-00

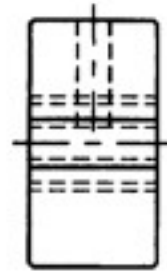
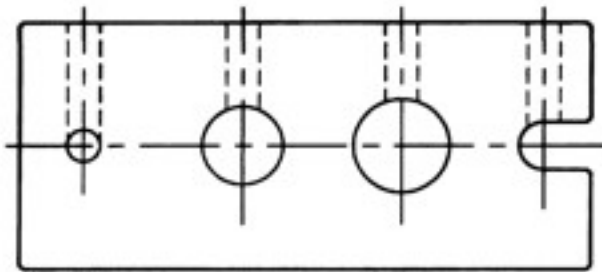



Contact Us

Elliott Tool offers a complete line of precision tube tools to meet your needs. Contact us or your local support.

Elliott Tool Technologies, Ltd.
1760 Tuttle Avenue
Dayton, Ohio 45403-3428
Phone: +1 937 253 6133 • +1 800 332 0447
Fax: +1 937 253 9189
www.elliott-tool.com

Locally Supported By:

www.elliott-tool.com/support