

# 99062 Series Electric Rolling Motor

For 1/4" – 5/8" (6.35mm – 15.88mm) Tube O.D.



Tube & Pipe Cleaners ◦ Tube Testers ◦ Tube Plugs ◦ Tube Removal ◦ Tube Installation



## Operating and Maintenance Instructions

**WARNING:** Read these instructions before using this tool.



# Table of Contents

Introduction .....	4
Safety Instructions.....	5
Setup.....	7
Troubleshooting Electric Rolling Motors.....	9
Care & Maintenance .....	10
Brush Replacement.....	11
99062 Series Parts Diagram.....	12
99062 Series Parts List .....	13
Technical Information .....	14
Warranty .....	15

# **Introduction**

Thank you for purchasing this Elliott product. More than 100 years of experience have been employed in the design and manufacture of this tool, representing the highest standard of quality, value and durability. Elliott tools have proven themselves in thousands of hours of trouble free field operation.

If this is your first Elliott purchase, welcome to our company; our products are our ambassadors. If this is a repeat purchase, you can rest assured that the same value you have received in the past will continue with all of your purchases, now and in the future.

The Elliott 99062 Series Electric Rolling Motor is to be used with the Elliott Model ELC110220 Electronic Torque Controller to expand tubes in the following types of equipment:

**Heat Exchangers**

**Condensers**

**Chillers**

**Evaporators**

**Air Conditioners**

If you have any questions regarding this product, manual or operating instructions, please call Elliott at +1 800 332 0447 toll free (USA only) or +1 937 253 6133, or fax us at +1 937 253 9189 for immediate service.

# Safety Instructions



1. Read all safety and operating instructions contained in this manual prior to use of the tool. Failure to follow all instructions listed below may result in electrical shock, fire and/or serious injury.
2. Do not operate this tool while under the influence of drugs or alcohol.
3. Do not operate this tool in an explosive atmosphere, such as in the presence of flammable liquids, gases or dust.
4. Check the motor, cable and plug prior to every use of the tool. Repair or replace any defective parts prior to use of the tool.
5. Do not use motor in wet conditions.
6. Use only extension cords and plugs approved for outdoor use when working outdoors.
7. Use appropriate safety equipment (i.e. safety glasses, ear plugs, dust masks, etc.) when using this tool.
8. Ensure that long hair or loose fitting clothes are secure prior to use of the tool.
9. Do not use motor without the additional handle.
10. Never apply the motor to an unsecured work piece.
11. Power cable should be located to the rear of the motor during operation, away from the rotating spindle.
12. Always hold the motor with both hands and maintain a safe stance during use.
13. Stay clear of any objects that may interfere with the operator's ability to maintain control of the motor as it reaches maximum torque.
14. Always disconnect the motor from the power source prior to performing any maintenance or repairs.

## **Protection**

To avoid damage to the tool and/or possible injury to the operator:

Do not continue to run the motor after the motor has reached its maximum torque.

Do not operate the motor beyond the maximum amperage rating shown on the name plate.

**Use only original replacement parts from the motor manufacturer.**

# Safety Recommendations

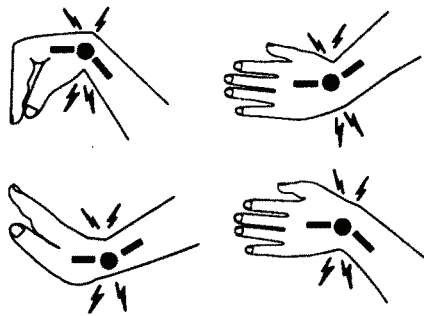

- Tasks should be performed in such a manner that the wrists are maintained in a neutral position which is not flexed, hyperextended, or turned side to side.
- Stressful postures should be avoided and can be controlled through tool selection and work location.

Any user suffering from prolonged symptoms of tingling, numbness, blanching of fingers, clumsiness or weakened grip, nocturnal pain in the hand, or any other disorder of the shoulders, arms, wrists, or fingers is advised to consult with a physician. If it is determined that the symptoms are job related or aggravated by movements and postures dictated by the job design it may be necessary for the employer to take steps to prevent further occurrences. These steps might include, but are not limited to, repositioning the workpiece or redesigning the workstation, reassigning workers to other jobs, rotating jobs, altering work pace, and/or changing the type of tool used so as to minimize stress on the operator. Some tasks may require more than one type of tool to obtain the optimum operator/tool/task relationship.

The following recommendations will help reduce or moderate the effects of repetitive work motions and/or extended vibration exposure.

- Use a minimum hand grip force consistent with proper control and safe operation.
- Keep wrists as straight as possible.
- Keep body and hands warm and dry.
- Avoid anything that inhibits blood circulation
  - Smoking tobacco
  - Cold temperatures
  - Certain drugs
- Avoid highly repetitive movements of hands and wrists, and continuous vibration exposure.

# Setup

## Connect to Torque Controller

To get full use of the auto-reverse and torque shut-off features, this motor must be used with the Elliott Model ELC110220 Electronic Torque Controller. Connect the 7-pin connector on the motor cord to the 7-pin socket on the torque controller. The controller will automatically detect whether the motor is 110V or 220V and whether the motor is auto-reversing or manual reversing. (Note: The operating voltage must correspond with the voltage indicated on the motor's name plate. 99062-110 motors designed for 110V can be used with 120V as well. 99062-220 motors designed for 220V can be used with 240V as well.

### CAUTION

Electric motors are designed to operate within a specific amperage range. Operating above the maximum specified amperage rating will result in damage to the motor.

When operating the motor in conjunction with Elliott's ELC110220 Torque Controller the following maximum settings must be followed:

Recommended Electrical Settings			
Model	Single Phase Voltage	Maximum Amperage	Maximum ELC110220 Setting
99062-110-7P	110	4.3	215
99062-220-7P	220	2.2	110

# Setup

## **⚠ CAUTION**

If using an extension cord, avoid excessive lengths and/or undersized wire gauge cords. The ELC110220 is designed to operate at a minimum voltage of 100 VAC. The use of an undersized extension cord can create a voltage drop that may adversely affect the operation of the ELC110220. An extension cord that is hot to the touch is most likely undersized and should be replaced with the next larger size wire.

Grounded power cords have plugs with three prongs and require a three wire extension cord. Double insulated power cords have plugs with two prongs and can use either two or three wire extension cords. As the distance from the supply outlet increases, you must use a heavier gauge extension cord. Using extension cords with inadequately sized wire causes a serious drop in voltage, resulting in loss of power. Refer to the chart below to determine the required minimum wire size.

### **Recommended Minimum Wire Gauge for Extension Cords**

Nameplate Amperes	Extension Cord Length					
	25' (7.6m)	50' (15.2m)	75' (22.8m)	100' (30.5m)	150' (45.7m)	200' (61.0m)
0.0 - 5.0	16	16	16	14	12	12



# Troubleshooting Electric Rolling Motors

Symptom	Possible Causes	Solution
<b>Motor won't run.</b>	Loose plug connections.	Ensure all plug connections are secure.
	Motor voltage doesn't match power source voltage.	Ensure that motor voltage matches the voltage of the power source.
	Torque controller is in "Auto" or "Assisted" mode & is waiting for additional input.	Check the torque controller dialog screen & enter info required.
<b>Motor will not shut off at controller setting.</b>	Limit setting on the torque controller is set too high.	Recalculate or reduce limit setting.
	Torque required exceeds motor capacity.	Set motor speed (if 2-speed) to lower speed or switch to larger motor.
	Motor set at low speed setting (2-speed motors only).	Set motor to high speed setting.
	Motor is too large for application.	Switch to a smaller motor.
	Defective trigger switch.	Replace the trigger switch.
	Defective motor.	Have the motor serviced by an authorized repair specialist.
<b>Motor runs hot.</b>	Motor is operating at or above its max. amperage rating.	Set motor speed (if 2-speed) to lower speed or switch to larger motor.
	Ambient temperature are high.	See Care & Maintenance on page 10.
	Defective motor.	Have the motor serviced by an authorized repair specialist.
<b>Motor will not auto-reverse.</b>	Loose plug connection.	Ensure plug connection to torque controller is secure.

# Care & Maintenance

Environments with high ambient temperatures require closer attention to care and use. In order to achieve optimal motor performance consider the following:

- **Clean Power**—The use of a reliable, consistent power supply will help minimize voltage fluctuations that can be harmful to the motor.
- **Ambient Temperature**—As the ambient temperature rises, so does the need for cooling. When used in high ambient temperature conditions, operators should run the motor under no load for 10 to 15 seconds periodically during the shift to enable ambient air to pass through the motor and cool the internal parts. Frequency and duration of cooling periods are dependent on the ambient temperature. If using in conjunction with Elliott ELC110220, this practice will not adversely affect the performance of the controller.
- **Cooling Motors**—In the event that conditions are so extreme that the cooling recommendation above is not sufficient, operators should consider implementing a multiple motor system where motors are run for a short period of time then allowed to rest while a secondary motor is put into service. Alternating motors in this manner will allow the motor to cool and avoid damage due to overheating.
- **Internal Operation Temperature**—The operating temperature of the internal components must not reach 284 degrees Fahrenheit (140 degrees Celsius).

To ensure years of reliable operation, follow these simple care and maintenance suggestions:

- Keep the motor clean and free of dirt and other contaminants.
- Do not allow contaminants inside the motor housing.
- When the brush lengths are .25" (6.35mm) or less, brushes need to be replaced. (See instructions below.) Brushes should be replaced by a maintenance technician. They must be run in by a 20 minute idle run of the tool. Also, the condition of the commutator must be checked. In case of irregular coloring of the individual blades and surface crashes, send the tool to an authorized service center.



## **Environmental Protection**

### **Raw Material Recycling instead of Waste Disposal**

The components that make up this tool, as well as its packaging, are made of recyclable materials and should be disposed of in accordance with local rules and regulations.

# Brush Replacement

## **When To Replace The Carbon Brushes:**

When the brush lengths are .25" (6.35mm) or less, brushes need to be replaced. Brushes are field-serviceable components and should be replaced by a maintenance technician.

- 1. Disconnect motor from any power source.**
2. Remove (7) side screws (Item 9) from the housing set (Item 8).
3. Slide out brush holder (Item 17) & carbon brush (Item 19) from the housing set (Item 16).
4. To remove the carbon brush from the brush holder, press the copper tab thru the window in the brush holder & pull the carbon brush free of the brush holder.
5. Insert the new carbon brush into the brush holder until the tabs click into place.
6. Slide the brush holder & carbon brush into slot in the housing set.
7. Repeat steps 2 thru 5 for replacing the carbon brush on the other side of the armature (Item 12).
8. Replace the housing set & the (7) side screws.

# 99062 Series Parts Diagram

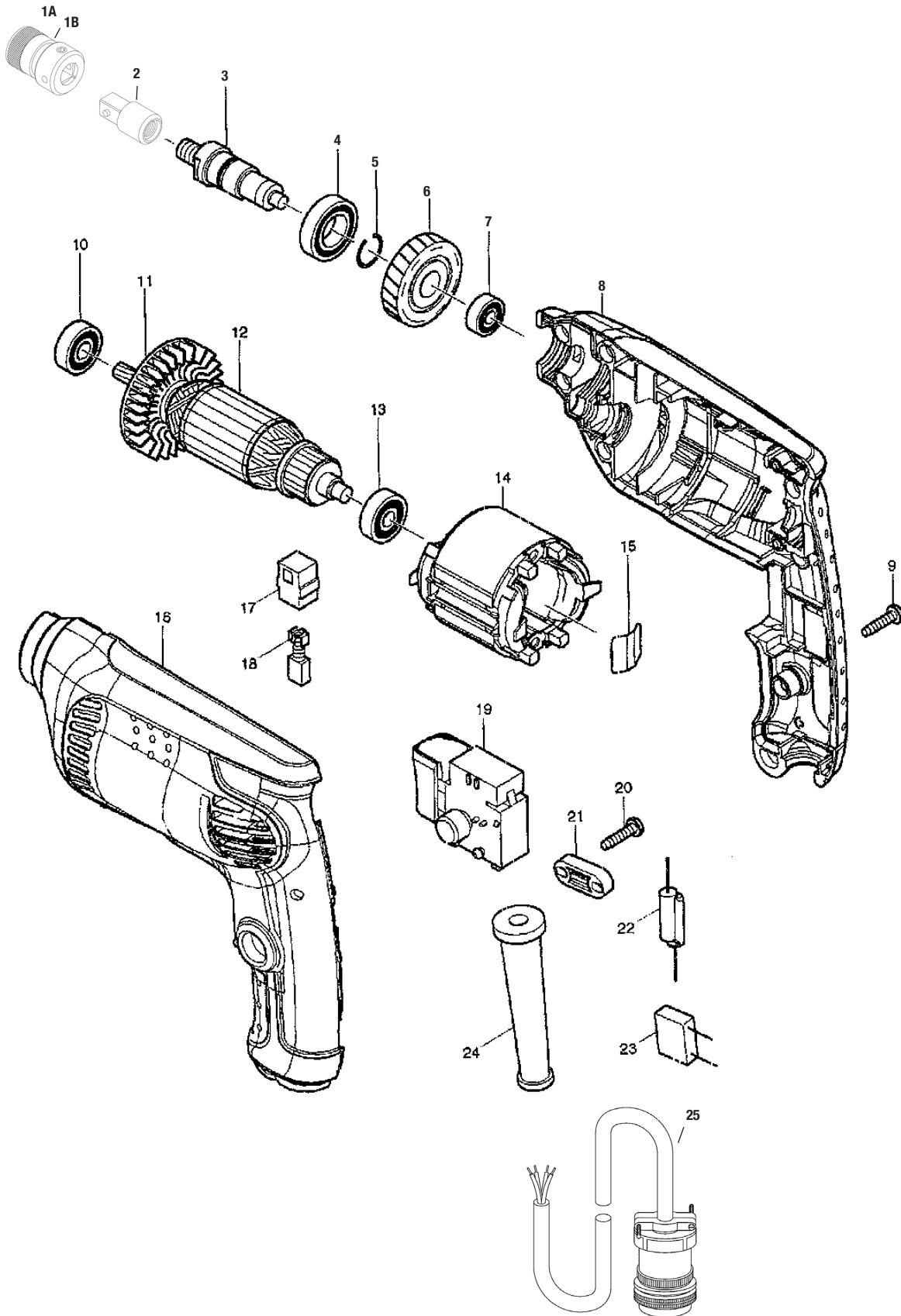

# 99062 Series Parts List

Item No.	Part Number	Description
1A	810-037-037	QR Chuck (3/8" Sq. both ends)
1B	810-025-037	QR Chuck (1/4" Sq. x 3/8" Sq.)
2	445903	Square Adapter
3	44-324376-4	Spindle
4	44-211242	Ball Bearing
5	44-233925-5	Retaining Ring
6	44-226578-7	Helical Gear
7	44-210028-2	Ball Bearing
8	44-188277-8	Housing Set
9	44-266326-2	Tapping Screw
10	44-211032-4	Ball Bearing
11	44-240066-0	Fan
12	44-515696-9	110V Armature
	44-515699-3	220V Armature
13	44-210030-6	Ball Bearing
14	44-593640-6	110V Field
	44-599369-2	220V Field
15	44-232210-3	Leaf Spring
16	44-188277-8	Housing Set
17	44-643563-9	Brush Holder
18	44-191627-8	Carbon Brush
19	44-650585-2	110V Switch
	44-650586-0	220V Switch
20	44-266326-2	Tapping Screw
21	44-687124-5	Strain Relief
22	44-646150-3	110V Choke Coil
	44-646151-1	220V Choke Coil
23	44-645190-8	Noise Suppressor
24	44-682504-0	Cord Guard
25	99062-110CC	110V Connection Cable
	99062-220CC	220V Connection Cable

# Technical Information

Rated Voltage:	110V / 120V (99062-110-7P)	220V / 240V (99062-220-7P)
Rated Power Input (Watts):	450	
Frequency:	50 – 60 Hz	
Max. Amperage:	4.3A (110V)	2.2A (220V)
ELC110220 Limit Setting:	215 (110V)	110 (220V)
Free Speed (No Load):	4250 (110V)	4000 (220V)
Max. Torque (In.-Lbs. / N*m):	15/1.7 @ 1900 RPM	
Protection Class:	II (Double Insulation)	
Degree of Protection:	IP 20	
Interference Suppression:	as per DIN VDE 0875, EN 55014	

All rights of changes due to technical development reserved.

## **Dimensions (without toolbox):**

Length (Inches / mm):	9.5 / 241.3
Width (Inches / mm):	2.5 / 63.5
Height (Inches / mm):	7 / 177.8
Weight (Lbs. / Kg):	2.7 / 1.2

## **Dimensions (with toolbox):**

Length (Inches / mm):	20 / 508
Width (Inches / mm):	10.5 / 266.7
Height (Inches / mm):	10 / 254
Weight (Lbs. / Kg):	6.3 / 2.9

# WARRANTY

Should any part, of Seller's own manufacture, prove to have been defective in material or workmanship when shipped (as determined by Seller), Seller warrants that it will, at its sole option, repair or replace said part f.o.b., point of manufacture, provided that Buyer notifies, in writing, of such defect within twelve (12) months from date of shipment from the manufacturing plant.

On request of Seller, the part claimed to be defective will be returned, transportation, insurance, taxes and duties prepaid, to the factory where made, for inspection. Any item, which has been purchased by Seller, is warranted only to the extent of the original manufacturer's warranty to Seller.

Seller shall not be liable for any damages or delays caused by defective material or workmanship.

No allowance will be made for repairs or alterations made by others without Seller's written consent or approval. If repairs or alterations are attempted without Seller's consent, Seller's warranty is void.

THE WARRANTIES PROVIDED IN THE OBLIGATIONS AND LIABILITIES OF SELLER HEREUNDER, AND THE RIGHTS AND REMEDIES OF BUYER HEREUNDER ARE EXCLUSIVE AND IN SUBSTITUTION FOR, AND BUYER HEREBY WAIVES ALL OTHER WARRANTIES, GUARANTEES, OBLIGATIONS, CLAIMS FOR LIABILITIES, RIGHTS AND REMEDIES, EXPRESS OR IMPLIED, ARISING BY LAW OR OTHERWISE, INCLUDING BUT NOT LIMITED TO THE IMPLIED WARRANTY FOR MERCHANTABILITY AND FITNESS FOR PURPOSE.

Seller's total liability is limited to the lower of the cost of repair or replacement.



## Contact Us

Elliott Tool offers a complete line of precision tube tools to meet your needs. Contact us or your local support.

Elliott Tool Technologies, Ltd.  
1760 Tuttle Avenue  
Dayton, Ohio 45403-3428  
Phone: +1 937 253 6133 • +1 800 332 0447  
Fax: +1 937 253 9189  
[www.elliott-tool.com](http://www.elliott-tool.com)

### Locally Supported By:

[www.elliott-tool.com/support](http://www.elliott-tool.com/support)