

Tube Expander Design & Usage

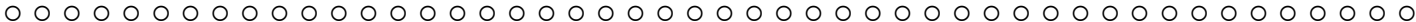

Choosing The Right Tube Expander To Meet Your Needs

Heat Exchanger Expander Needs Assessment

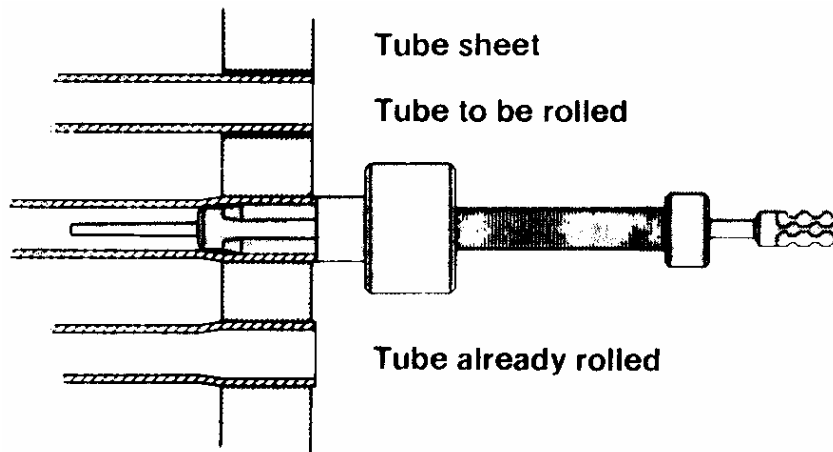

- Tube material.
- Tube OD.
- Tube wall thickness (BWG).
- Tube sheet thickness.
- Any obstructions - waterbox or channel plate, tube projections, etc.

Calculating The Rolled Inside Diameter

- Rule of thumb: the harder the material, less wall reduction required.
- Percent wall reduction guidelines:
 - Copper & cupro-nickel – 8% to 10%
 - Steel, carbon steel, admiralty brass – 7% to 8%
 - Stainless steel, titanium – 4% to 5%
 - 3003 or 4004 aluminum – 5% maximum
 - 6061T aluminum – 10% to 12%

Determining 3, 4 or 5 Roll Expander Design

- Generally a 3 roll expander is well suited but inquire about:
 - Tube material:
 - Stainless steel, titanium:
 - Work – hardening materials.
 - Minimum 4-roll design, if possible.
 - Wall thickness:
 - 20 gage (.035”) & thinner:
 - Stainless steel, titanium – 5 roll preferred.
 - Carbon steel, brass, copper, aluminum – 4 roll preferred.
 - Tube pitch:
 - Tube sheets with thin ligaments in a triangular tube pitch pattern may be disrupted using a standard 3 roll expander.

When To Use 4 Or 5 Roll Expanders

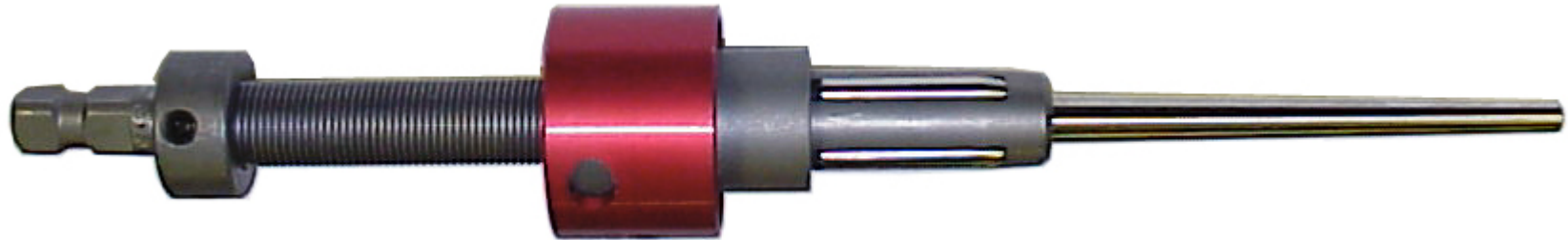

- Tube materials:
 - Stainless steel.
 - Titanium.
 - Other exotic alloys.
 - Materials that work harden rapidly.
- Tube sheets with thin ligaments in a triangular pitch.

Other Factors That May Effect Expander Design

- Flush, recess, telescoping or friction collar?



Flush Collar

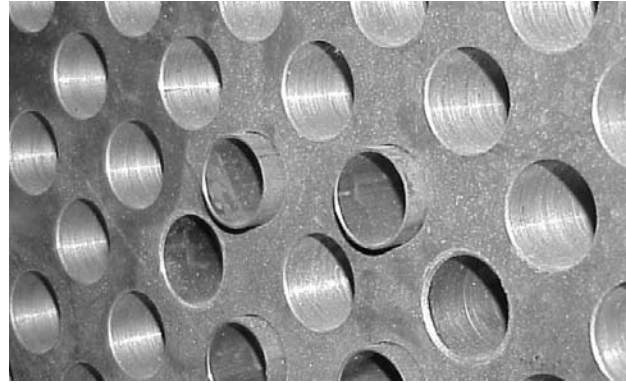

Friction Collar

- Tube bend.

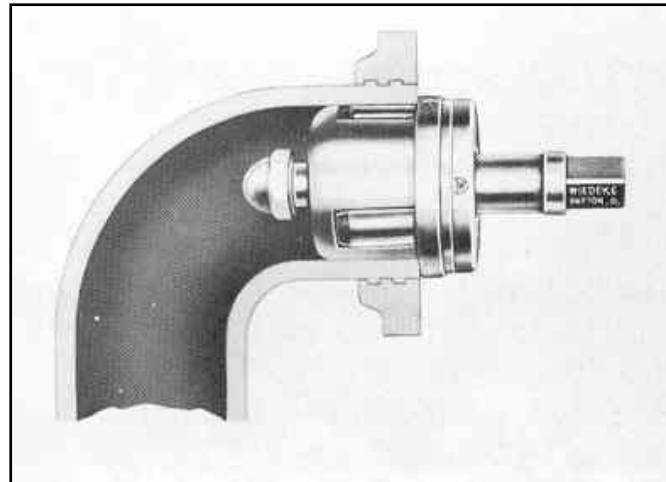

When Is The Reach Of An Expander Important?

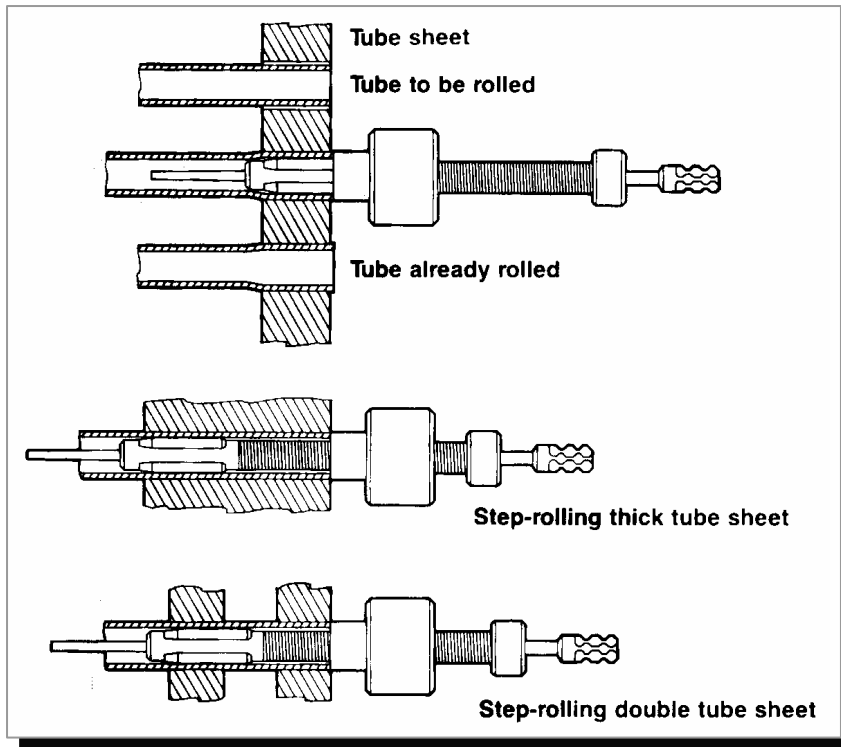

- When the depth of the tube sheet is greater than the effective roll length.
- For double tube sheets.
- Fin fan coolers.

Importance Of Sealing Full Length Of Tube Sheet

- No matter the method, seal the full length of tube sheet.
- If less than full length, medium is condensed and trapped between tube and tube sheet. This will lead to premature seal deterioration and tube decay.
- If tube is expanded beyond tube sheet thickness, tube bulging creates a sharp edge which weakens the tube.

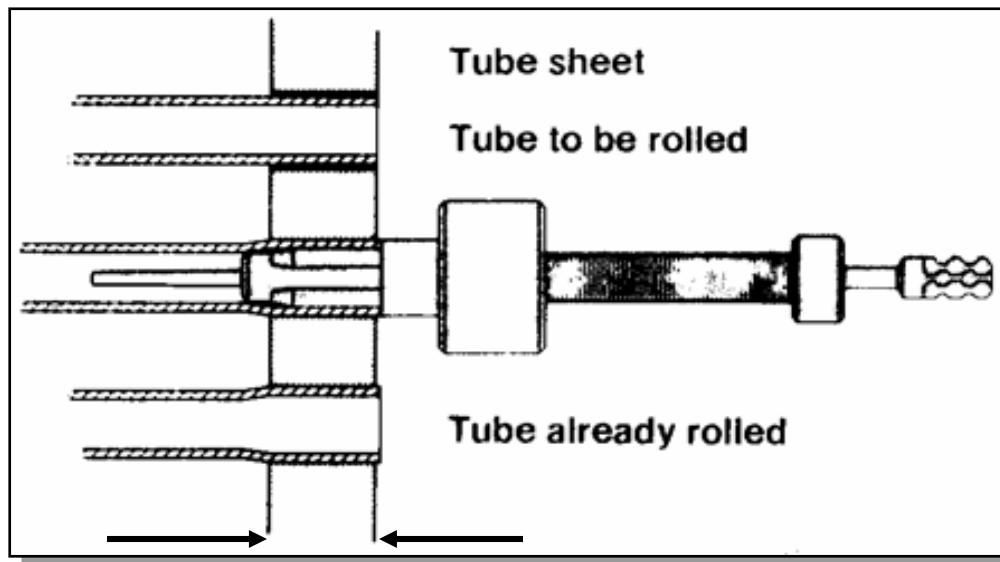

Improving Tube Expansion Quality & Maximizing Tool Life



How A Mechanical Bond Is Formed

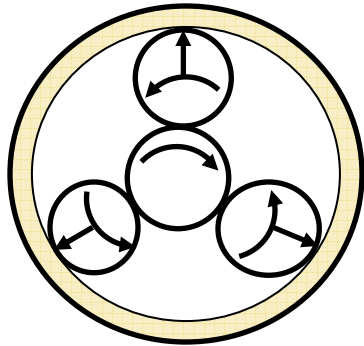

- Tube Joint formed by compressing the tube into a fixed container (i.e. tube sheet).
- Ideally rolled joint created when the tube state turns to plastic (stays where it stops) and is contained by the tube sheet's elastic properties (fully recovers). This has to occur right before the tube sheet turns to a plastic state.

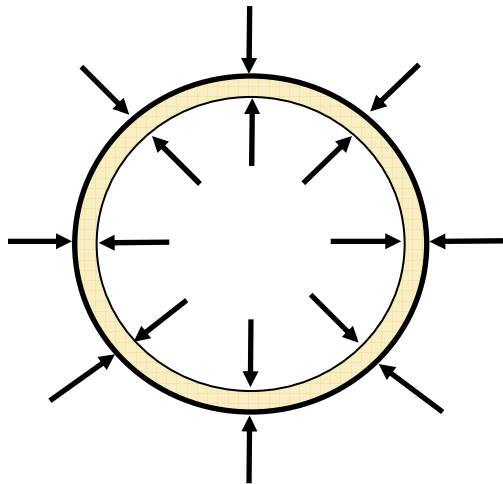

- Under-rolling occurs when the tube is not compressed enough and remains at an elastic stage. Bond is not created as yield of material is not compressed enough to turn tube sheet to elastic.
- Over-rolling occurs when tube surpasses the elastic property of tube sheet and therefore the ligaments between tube sheet holes are shifted causing adjacent tubes to leak.

Tube: Plastic

Tube Sheet: Elastic



Common Causes Of Tube Joint Failure

- Not enough tube expansion (under rolling).
- Too much tube expansion (over rolling).
- Dirty, scratched tubes or tube sheets.
- Dents or other imperfections of the tube.

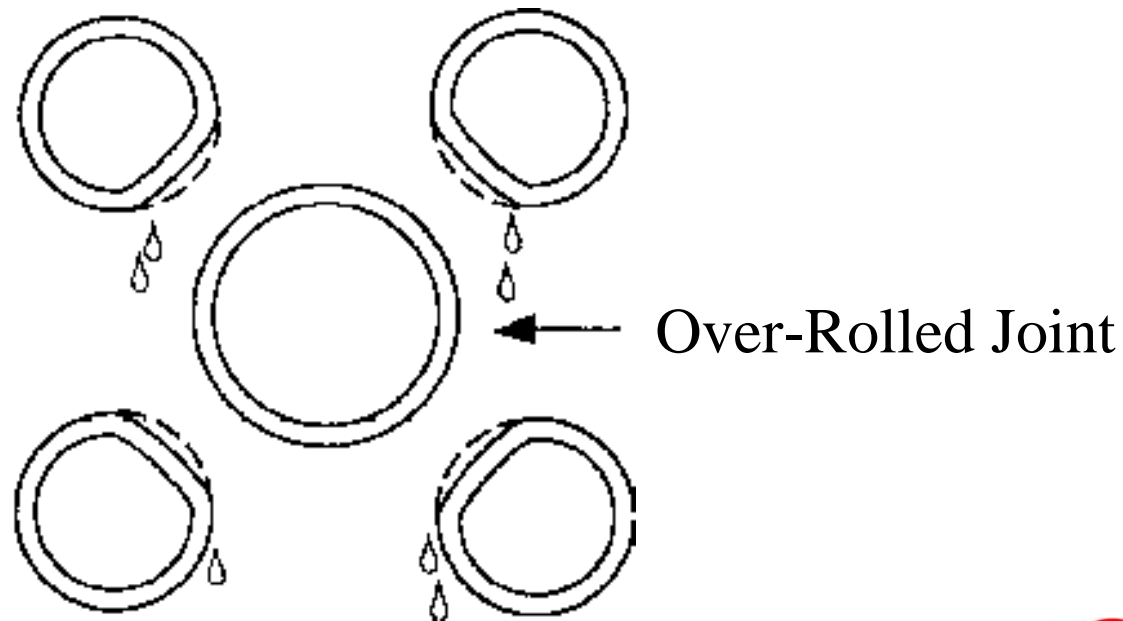

Calculating The Rolled Inside Diameter

- Percent tube wall reduction guidelines:
 - Rule of thumb: Harder the material, less wall reduction required.
 - Copper & Cupro-Nickel – 8% - 10%
 - Steel, Carbon Steel, Admiralty Brass – 7% - 8%
 - Stainless Steel, Titanium – 4% - 5%
- The above are guidelines and may not apply specifically to your design requirements.

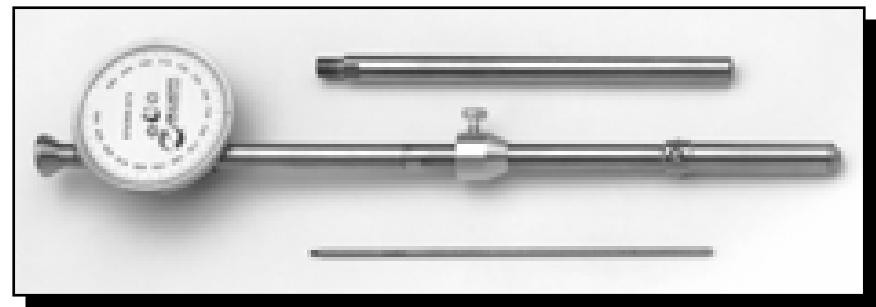

Rolled ID Calculation

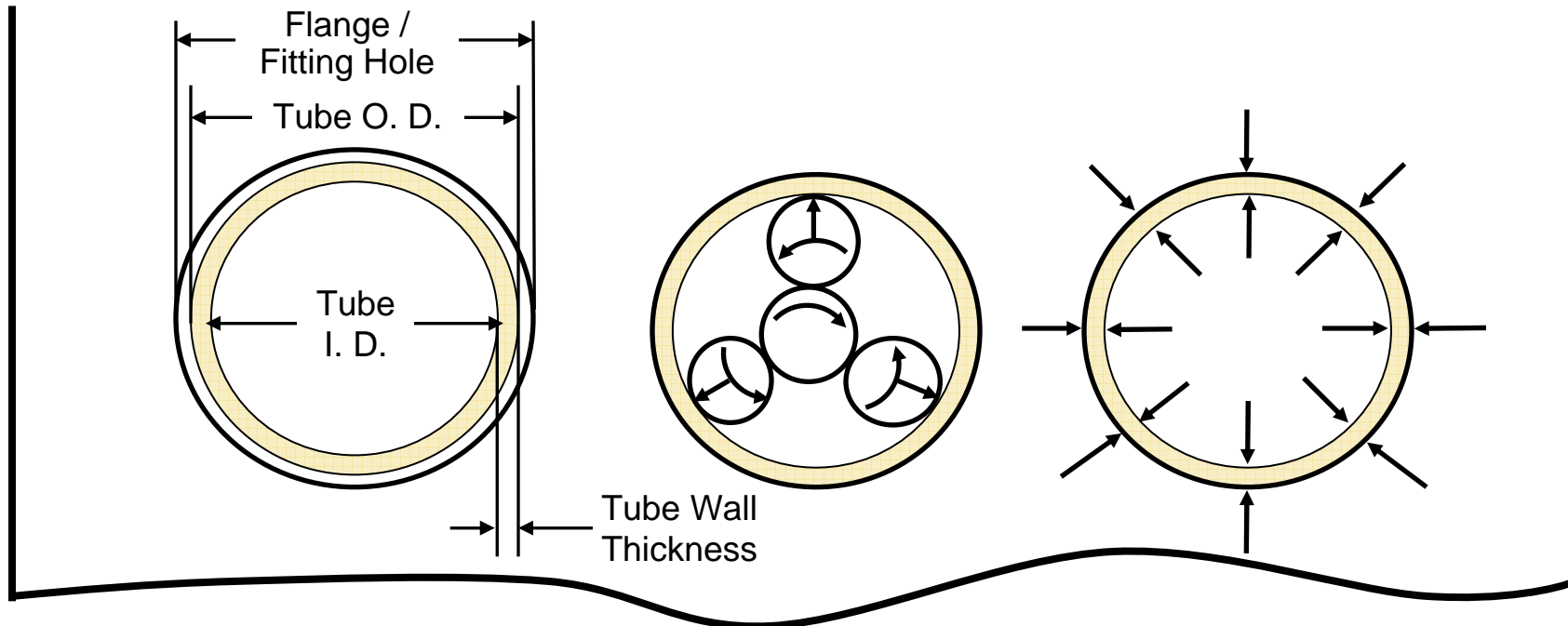

Tube Example
3/4" 16 Ga.
Brass Tube

Step	Step Description	Example
A	Measure Flange / Fitting Hole	0.760
B	Measure Tube O. D.	0.750
C	Calculate Clearance (A-B)	0.010
D	Measure Tube I. D.	0.620
E	Calculate Total Tube Wall Thickness (B-D)	0.130
F	Calculate Wall Reduction (7%)	0.009
G	Calcualte Finished Rolled Tube I. D. (C+D+F)	0.639



Expansion Calculation Tool Is Available From Elliott



Date: 19-Feb-05 Last Update: 3/15/02

ACTUAL MEASUREMENTS

Nominal Sizes	Sample 1	Sample 2	Sample 3	Sample 4	Sample 5	Sample 6	Sample 7	Sample 8	Sample 9
Tube Material:	Stainless	Stainless	0.00	0.00	0.00	0.00	0.00	0.00	0.00
Sheet Hole Diameter:	0.381	0.507							
Tube OD:	0.375	0.500	0.000	0.000	0.000	0.000	0.000	0.000	0.000
Tube Gauge (BWG):	20	18	0	0	0	0	0	0	0
Initial Tube ID:	0.305	0.402							

APPLICATION

Wall Thickness (Gage):	0.035	0.049							
Clearance:	0.006	0.007							
ID at Metal To Metal:	0.311	0.409							
Min Wall Crush %:	4	4	#N/A	#N/A	#N/A	#N/A	#N/A	#N/A	#N/A
Max Wall Crush %:	5	5	#N/A	#N/A	#N/A	#N/A	#N/A	#N/A	#N/A
Tube ID at Min Crush:	0.314	0.413	#N/A	#N/A	#N/A	#N/A	#N/A	#N/A	#N/A
Tube ID at Max Crush:	0.315	0.414	#N/A	#N/A	#N/A	#N/A	#N/A	#N/A	#N/A
Torque Box Setting:									
Tube ID After Rolling*:									
Under or Overall(-):			#N/A	#N/A	#N/A	#N/A	#N/A	#N/A	#N/A
% Wall Reduction Achieved:			#DIV/0!	#DIV/0!	#DIV/0!	#DIV/0!	#DIV/0!	#DIV/0!	#DIV/0!
Travel from Initial ID:									

ID Range

Data Entry Fields

Calculated Automatically

ELLIOTT TOOL TECHNOLOGIES

1760 Tuttle Ave., Dayton, OH 45403 U.S.A.

Toll Free. 1.800.332.0447 Tel. 937.253.6133 Fax. 937.253.9189

www.elliotttool.com If you need Tube Tools, click [here](#)



Proper Operation For Effective Joints & Tool Life

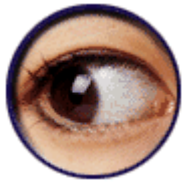

Visual Inspection

- The tube surfaces must be clean of debris, scratches, dents, cracks and any other imperfections of the tube.
- Inspect the tube sheet where tube is being expanded into, for any radial or longitudinal imperfections.

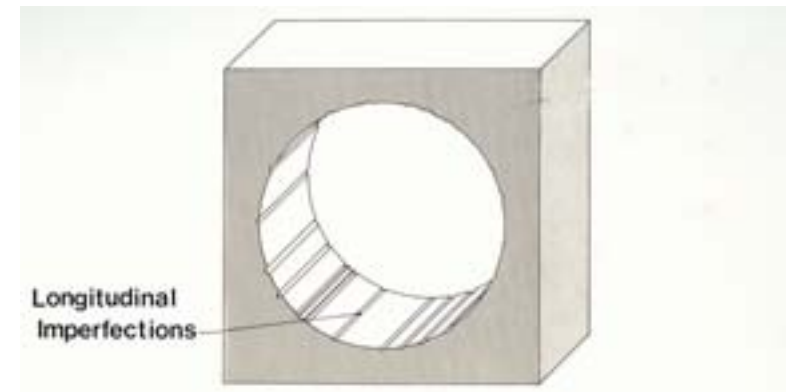
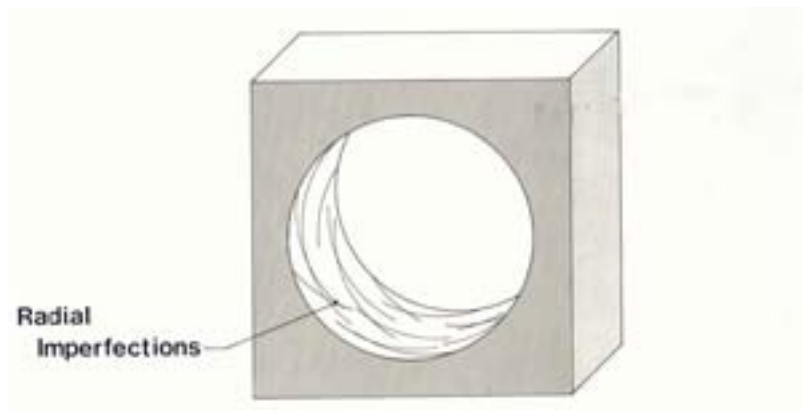

Proper Operation For Effective Joints & Tool Life

- The expander must also be clean and free from debris.
- Any visible signs of wear on the expander's rolls and mandrel - replace these items immediately.
- The expander must have the rollers and mandrel well lubricated to prolong tool life.
 - The kind of lubricant will make a difference. Use Elliott recommended!
- The expander's thrust bearings must have liberal amounts grease to reduce friction. (Extremely important if rolling the joint to a torque).



Tips To Improve Tool Life

- Use 2 Expanders alternatively for one operator. Place one expander in lubricant while the other one is under rolling operation.
- Exchange expander about every 50 joints to allow for proper cool-off and lubrication. Use Quick Change Chuck to minimize downtime.
- Every 5-7 complete exchanges, check for debris trapped between mandrel and rolls. Disassemble and clean if required. Ensure thrust bearings have liberal amounts of grease.
- Roll to suggested tube wall reduction using a Torque Control Box. This ensures repeatability of Joint Tightness and reduces overheating of tube expander and components.
- Hold Rolling Motor in a vertical / straight position and avoid motor to weigh on the mandrel to avoid possible axial load on the mandrel creating fatigue and premature tool breakage.
- Use double-radius rolls when rolling inside the tube sheet (or inner-sheet). This will avoid sharp edges inside the tube that will cause strain on the mandrel when withdrawn.



