

Elliott offers a complete line of precision tube tools, including:



**tube
expanders**

- Boiler Expanders
- Heat Exchanger Expanders
- Condenser Expanders
- Refinery Expanders

**tube rolling motors
& torque controls**

- Electric
- Pneumatic

**tube
cleaners**

- Air & Water Driven Motors
(Internal/External Drives)
- Jiffy Guns
("Shoot-Thru" Devices)
- Roto-Jet
(Rotating Flex Shaft)

**additional
products**

- Tube and Joint Testers
- Tube Plugs
(High & Low Pressure)

**retubing
tools**

- Tube Gauges
- Tube Cutters
- Manual Tools
- Spear Type Tube Pullers
- Collet-Type Tube Pullers
- CYCLGRIP Tube Extractors
- Grooving Tools
- End-Prep Tools

**metal working
products**

- Back Chamfering Tools
- Carbide Roller Burnishing Tools
- Diamond Burnishing Tools
- Elliptical Deburring Tools
- Fine Boring Tools
- Internal Recessing Tools
- Magic Vise
- Mechanical Joining Tools
- Roller Burnishing Tools
- Single Blade Reamers

Model 512500 & 512500AP (Air Purge) Condenser Cleaner

For Tube I.D. 1/2" to 2"
(12.7mm thru 50.8mm)



Operating and Maintenance Instructions

Elliott Tool Technologies Ltd • 1760 Tuttle Avenue • Dayton, Ohio 45403 U.S.A.
Phone: +1 800 332 0447 • +1 937 253 6133 • Fax: +1 937 253 9189

Elliott Tool Technologies UK Ltd • Broadstone Hill • Old Chalford • Chipping Norton • OXON • OX7 5QL • England
Phone: +44 (0) 1608 672815 • Fax: +44 (0) 1608 672810



Drills and Brushes

Condenser and Heat Exchanger Tube Cleaning Drills and Brushes for 5224XL and 5125 Tube Cleaners

CT Drill



Drill Tip



For Gummy Deposits.

Twist Drill



These drills are carbide tipped for hard deposits.

El Paso Drill



For Soft Deposits.

Fulfilled Brush



For Powder Deposits and Polishing.

Tube OD	Tube Gauge	Tube ID		*CT Drill Part No.	*Drill Stud Part No.	**Drill Tip Part No.	**Drill Coupling Part No.	El Paso	**Twist Drills	*** Brush	Cleaning Shaft OD Inch (mm)	
		Inch	mm									
1/2" (12.7mm)	16	.370"	9.40	5029-359	5039K	Not Available	Not Available	5005-359	Not Available	5024A22	5/16" (7.94mm)	
	17	.384"	9.75					5029-390		5005-390		5024A24
	18	.402"	10.21					5029-390		5005-390		5024A24
5/8" (15.8mm)	12	.407"	10.32	5029-422	5039A	5100-422	5100B	5005-422	5172-426	5024B26	3/8" (9.52mm)	
	13	.435"	11.05	5029-446		5100-468	5100C	5005-468	5172-468	5024B28		
	14	.459"	11.66	5029-480	5039B	5100-480		5005-480	5172-475	5226C30		
	15	.481"	12.22			5029-512		5100-512	5005-512	5172-475	5226C32	
	16	.495"	12.57	5029-512	5039C	5100-512		5005-512	5172-507	5226C32		
	17	.509"	12.93				5226C34					
3/4" (19.0mm)	12	.532"	13.51	5029-568	5039D	5100-568	5100P	5005-568	5172-564	5226D36	1/2" (12.7mm)	
	13	.560"	14.22							5029-604		5100-604
	14	.584"	14.83	5029-640		5100-640	5100E	5005-640	5172-632	5226D40		
	15	.606"	15.39							5226D42		
	16	.620"	15.75	5029-691		5100-691	5100F	5005-691	5172-689	5226D44		
	17	.634"	16.10							5226D46		
7/8" (22.2mm)	12	.652"	16.56	5029-727	5039E	5100-727	5100G	5005-727	5172-725	5226D46	5/8" (15.88mm)	
	13	.685"	17.40							5029-759		5100-759
	14	.709"	18.01	5029-759		5100-759	5100F	5005-759	5172-757	5226D48		
	15	.731"	18.57							5226D50		
	16	.745"	18.92	5029-812		5039F	5100-812	5100G	5005-812	5172-814		5226E52
	17	.759"	19.28									5029-848
18	.777"	19.74	5029-880	5039G	5100-880	5005-880	5172-882	5226E564				
1" (25.4mm)	12	.782"	19.86	5029-812	5039F	5100-812	5100G	5005-812	5172-814	5226E52	3/4" (19.05mm)	
	13	.810"	20.57							5029-848		5100-848
	14	.834"	21.18	5029-848		5100-848	5100G	5005-848	5172-850	5226E54		
	15	.856"	21.74							5226E564		
	16	.870"	22.09	5029-880		5039G	5100-880	5005-880	5172-882	5226E564		
	17	.884"	22.45									
18	.902"	22.91										

* Drill studs are required for CT type drills.
 ** Drill couplings are required for drill tips and twist drills.
 *** Brush standard material is steel, brushes are also available in brass and stainless steel materials.
 Other size drills and brushes are available, contact Customer Service for details.

SHAFTING & COUPLINGS

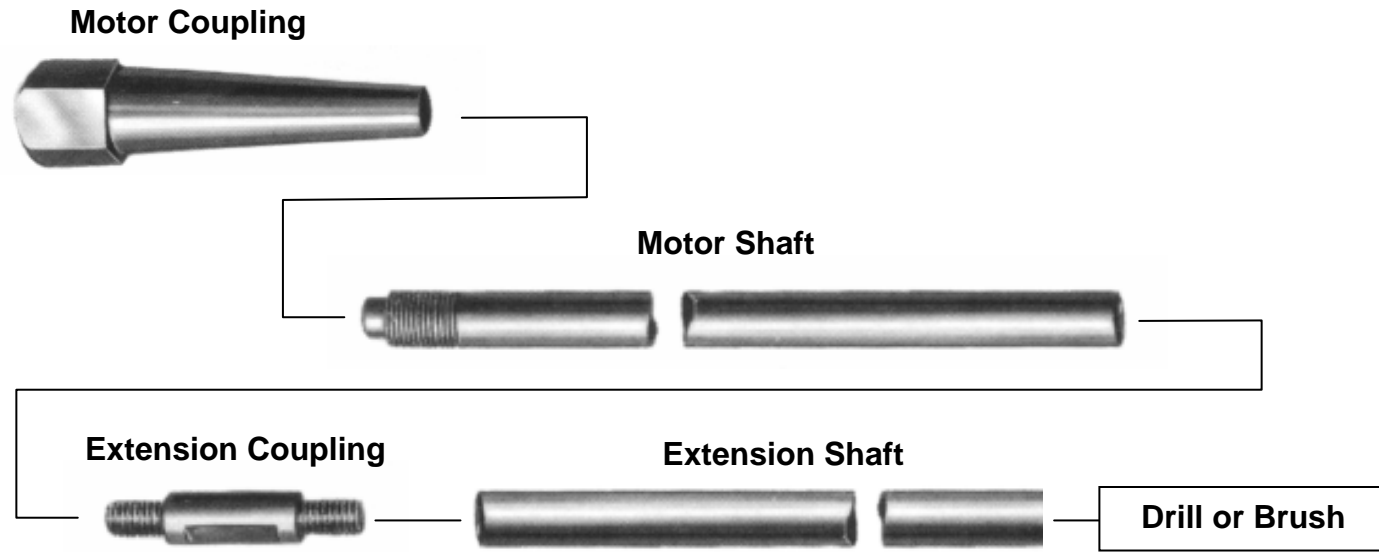

Shaft Outside Diameters	Motor Coupling Part No.	*Motor Shaft Part No.	Ext. Coupling Gasket Part No.	Extension Coupling Part No.	Extension Shaft Part No.
5/16" (7.9mm)	5213C	5213-(FT)	Not Available	Not Available	Not Available
3/8" (9.5mm)	5214C	5214-(FT)	P5034A	501406	5014-(FT)
7/16" (11.1mm)	5215C	5215-(FT)	P5034A	CS113106	5015-(FT)
1/2" (12.7mm)	5216C	5216-(FT)	P5034B	CS113206	5016-(FT)
5/8" (15.9mm)	5218C	5218-(FT)	P5034C	CS113406	5018-(FT)
3/4" (19.1mm)	5219C	5219-(FT)	P5034D	CS113506	5059-(FT)

* Specify Shaft length in feet. (Other sizes are available, contact Customer Service for details)

How to order Tube Cleaner Shafting, Accessories, Drills and Brushes:

- Measure the tube ID behind the tube sheet in the unrolled area
- Measure the length of the tube(s) to be cleaned
- Identify the type of deposit to be removed. (Hard, Soft, Gummy or Powder)
- Select proper type and size drill and/or brush for the deposit being removed.
- To select proper size Motor Coupling, Motor Shaft, Gaskets, Extension Couplings, and Extension Shafts refer to the cleaning shaft OD for the drills and/or brushes selected in the right hand column on the following page. Then refer to the shaft OD in the chart above to select the proper components.
- It is recommended to brush the tubes after they are cleaned with a drill to remove any residual debris and to polish the tube's ID.

Note: Although Motor Shafts are available in lengths of up to 18 feet (5.5M) they are not readily available. Motor and Extension shafting are readily available in 5' (1.5M) and 10' (3M) lengths for handling, storage and shipping purposes. (Maximum length to ship UPS is 5' (1.5M))

TABLE OF CONTENTS

Introduction Page 2

Safety Page 3

Operation Instructions..... Page 4

Maintenance Instructions..... Page 5

Trouble Shooting Page 6

Motor Specifications Page 6

512500 Parts List..... Page 7

512500AP Parts List..... Page 8

Shafting & Couplings Page 9

Drills & Brushes Page 10

INTRODUCTION

Thank you for purchasing this Elliott product. More than 100 years of experience have been employed in the design and manufacture of this tool, representing the highest standard of quality, value and durability. Elliott tools have proven themselves in thousands of hours of trouble free field operation.

If this is your first Elliott purchase, welcome to our company; our products are our ambassadors. If this is a repeat purchase, you can rest assured that the same value you have received in the past will continue with all of your purchases, now and in the future.

The Elliott Model 5125 and 5125AP (Air Purge) Condenser Cleaners are designed to provide high-torque for cleaning hard scale, coke, gummy, oily, or rubbery deposits from straight tubes 1/2" to 2" (12.7 to 50.8mm) I.D.. Ideal tools for sugar, pulp, paper mills, chemical plants, and oil refineries.

Model 5125 is water-flush operation – convenient for flushing away heat transfer deposits. Model 5125AP is an air-purge unit, for use where water-flush cannot be used.

SAFETY

Read and save all instructions. Before use, be sure everyone using this tool reads and understands this manual, as well as any labels packaged with or attached to the tool.

- 1. Know Your Elliott Condenser Cleaner Motor.** Read this manual carefully to learn your tool's applications and limitations, as well as potential hazards, associated with this type of equipment.
- 2. Keep Work Area Clean and Well Lighted.** Cluttered, dark work areas invite accidents.
- 3. Dress Properly.** Do not wear loose clothing or jewelry. Wear a protective hair covering to contain long hair. It is recommended that the operator wear safety glasses with side shields or a full face shield eye protection. Gloves and water repellent, nonskid footwear are also recommended. Keep hands and gloves away from moving parts.
- 4. Use Safety Equipment.** Everyone in the work area should wear safety goggles or glasses with side shields complying with current safety standards. Wear hearing protection during extended use, respirator for a confined space and a dust mask for dusty operations. Hard hats, face shields, safety shoes, respirators, etc. should be used when specified or necessary.
- 5. Keep Hands Away From Rotating Shafting.** DO NOT put hands on the shafting, motor coupling, or any tool attachment while it is rotating, as this could result in serious injury.
- 6. Keep Bystanders Away.** Bystanders should be kept at a safe distance from the work area to avoid distracting the operator and contacting the tool.
- 7. Protect Others in the Work Area** from debris such as coolant spray. Provide barriers or shields as needed.
- 8. Use Proper Accessories.** Use Elliott accessories only. Be sure accessories are properly installed and maintained. Do not defeat the purpose of a guard or other safety device when installing an accessory or attachment.
- 9. Check for Damaged Parts.** Inspect guards and other parts before use. Check for misalignment, binding of moving parts, improper mounting, broken parts or any other conditions that may affect operation. If abnormal noise or vibration occurs, stop the tool immediately and have the problem corrected before further use. Do not use a damaged tool. Tag damaged tools "Do Not Use" until repaired. A guard or other damaged part should be properly repaired or replaced by an Elliott service facility or qualified repairman. For all repairs, insist on only identical replacement parts.
- 10. Remove All Wrenches.** Check that all accessory wrenches are removed from the system before turning it on.

512500AP CONDENSER MOTOR (Air Purge)

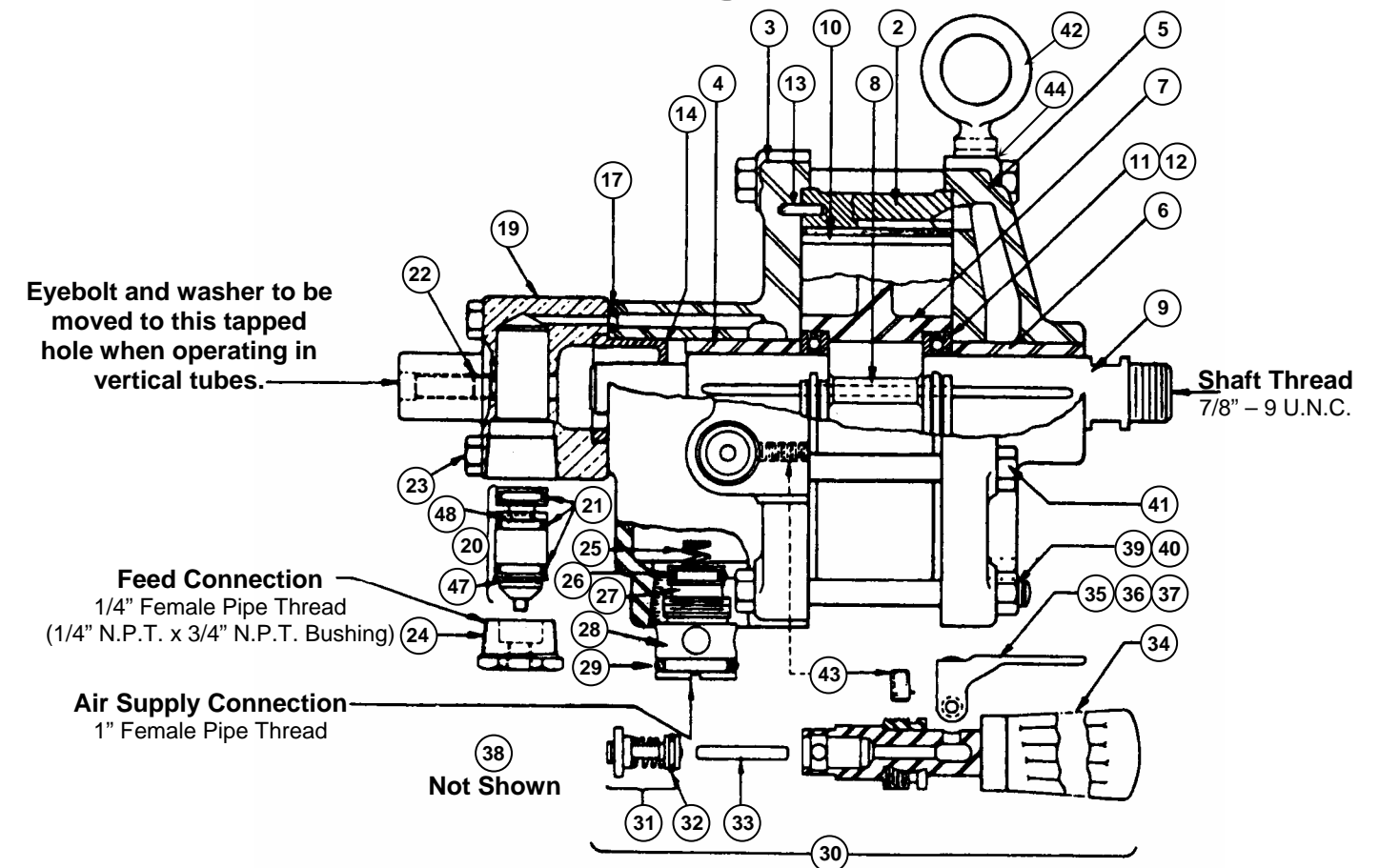

NOTE: Motors with serial number preceding 19289 will be repaired with old style valve. (Detail number 20)

ITEM NO.	PART NAME	NO. REQ'D.	PART NUMBER
1	Motor Assembled		512500AP
2	Body	1	504201
3	Inlet End	1	512502A
4	Inlet End Bushing	1	512503
5	Exhaust End	1	512505
6	Exhaust End Bushing	1	512507
7	Rotor	1	512509
8	Rotor Key	1	512510
9	Shaft	1	512511
10	Paddle	4	512513
11	Ball Thrust Bearing	2	P112454
12	Ball Thrust Plate	4	512512
13	Dowel	2	P8383-12
14	Packing Box	1	512516
15			
16			
17	Connecting "O" Ring	1	P8309-5
18			
19	Water Feed Valve Body	1	512519-2A
20	Water Feed Valve	1	512520-2
21	Feed Valve "O" Ring	3	P8309-11
22	Valve Unit Set Screw	1	128A
23	Feed Valve Cap Screw	4	130BK
24	Reducing Bushing	1	119N

ITEM NO.	PART NAME	NO. REQ'D.	PART NUMBER
25	Main Valve Spring	1	P512521
26	Main Valve "O" Ring	1	P8309-13
27	Main Valve	1	512522
28	Main Valve Body	1	512521
29	Valve Body "O" Ring	1	P8309-18
30	Valve Handle Assembled	1	512530
31	Trigger Valve Assembled	1	512540
32	Trigger Valve "O" Ring	1	P8309-7
33	Trigger Valve Push Rod	1	512530E
34	Handle Grip	2	P512527
35	Trigger	1	512530K
36	Trigger Roller	1	512530H
37	Trigger Roller Pin	1	P8383-16
38	Dead Handle	1	512527
39	Body Bolt	6	P8296F
40	Body Bolt Nut	6	171Q
41	Body Cap Screw	2	163CT
42	Eye Bolt	1	512543
43	Valve Handle Lock Screw	2	108N
44	Eye-Bolt Lock Washer	1	133C
45	Shaft Wrench	1	149E
46	"Allen" Wrench	1	P8369E
47	Feed Valve "O" Ring	1	P8309-6
48	Feed Valve "O" Ring	1	P8309-5

512500 CONDENSER MOTOR

OPERATION

(Refer to pages 7, 8, and 10 for items referenced in instructions listed below)

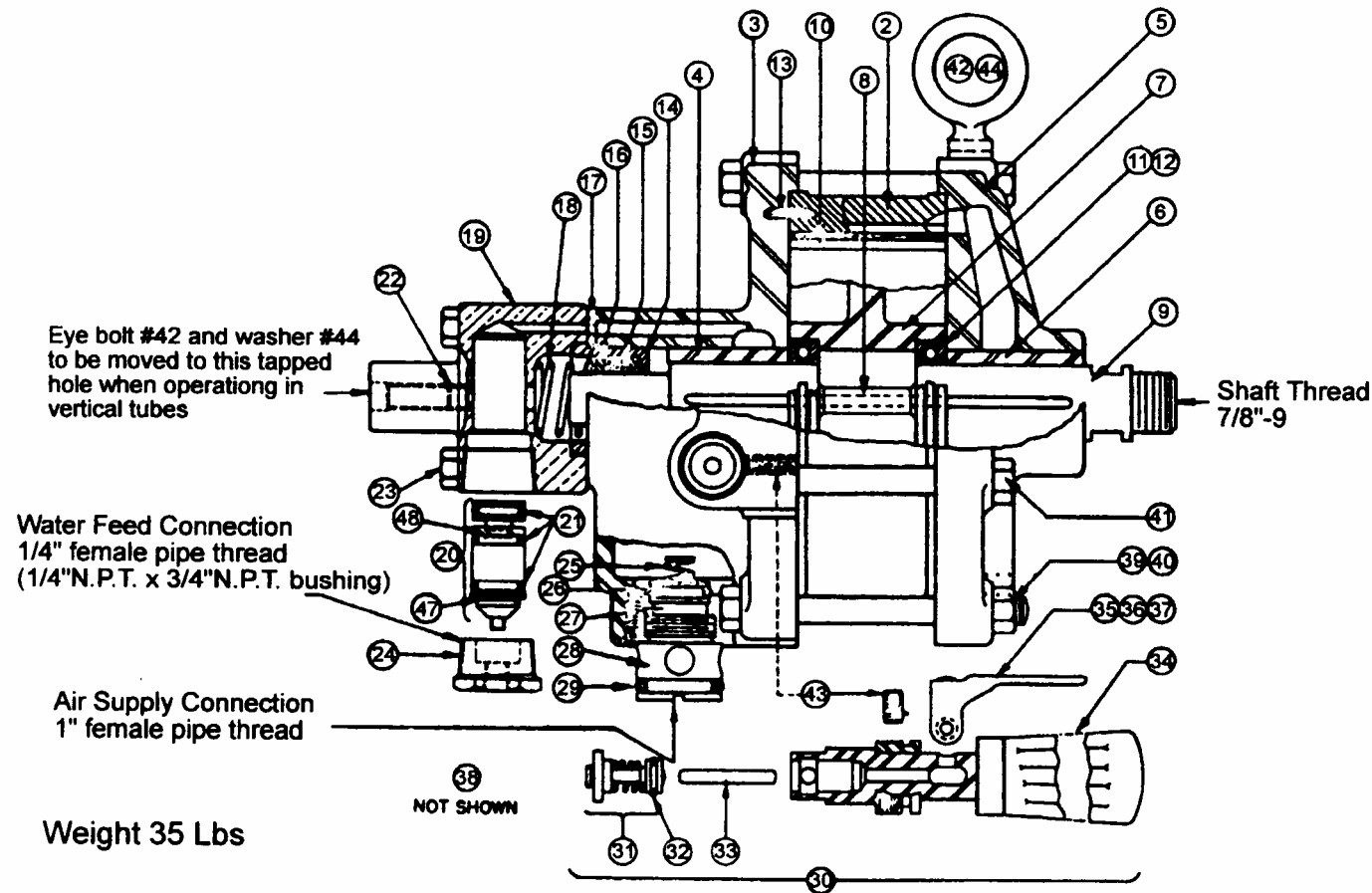

NOTE: motors with serial number preceding 19289 will be repaired with old style valve. (detail number 20)

ITEM NO.	PART NAME	NO. REQ'D.	PART NUMBER	ITEM NO.	PART NAME	NO. REQ'D.	PART NUMBER
1	Motor assembled	1	512500	25	Main valve spring	1	P512521
2	Body	1	504201	26	Main valve "O" ring	1	P8309-13
3	Inlet end	1	512502A	27	Main valve	1	512522
4	Inlet end bushing	1	512503	28	Main valve body	1	512521
5	Exhaust end	1	512505	29	Valve body "O" ring	1	P8309-18
6	Exhaust end bushing	1	512507	30	Valve handle assembled	1	512530
7	Rotor	1	512509	31	Trigger valve assembled	1	512540
8	Rotor Key	1	512510	32	Trigger valve "O" ring	1	P8309-7
9	Shaft	1	512511	33	Trigger valve push rod	1	512530E
10	Paddle	4	512513	34	Handle grip	2	P512527
11	Ball thrust bearing	2	P112454	35	Trigger	1	512530K
12	Ball thrust plate	4	512512	36	Trigger roller	1	512530H
13	Dowel	2	P8383-12	37	Trigger roller pin	1	P8383-16
14	Packing box	1	512516	38	Dead handle	1	512527
15	Packing	2	512531	39	Body bolt	6	P8296F
16	Packing follower	1	512517	40	Body bolt nut	6	171Q
17	Connecting "O" ring	1	P8309-5	41	Body cap screw	2	163CT
18	Packing spring	1	P512518	42	Eye bolt	1	512543
19	Water feed valve body	1	512519-2A	43	Valve handle lock screw	2	108N
20	Water valve "O" ring	1	512520-2	44	Eye-bolt lock washer	1	133C
21	Feed valve "O" ring	3	P8309-11	45	Shaft wrench	1	149F
22	Valve unit set screw	1	128A	46	"Allen" wrench	1	P8369E
23	Feed valve cap screw	4	130BK	47	Feed valve "O" ring	1	P8309-6
24	Reducing bushing	1	119N	48	Feed valve "O" ring	1	P8309-5

GENERAL INSTRUCTIONS:

A clean lubricated air supply must be available at 90 to 125 psi (6.2 to 8.6 Bar), and not less than 175 cfm (5 M³/min.), at the point of connection to the motor. A shut-off valve should be provided at the air supply connection source. If there is any doubt about the cleanliness of the air supply, a filter should be installed at the supply connection.

Motors 512500 & 512500AP (Air Purge) weigh approximately 35 lbs. (15.9 Kg) and it is recommended that an overhead support that allows some maneuverability be made available for ease of handling.

Proper lubrication of the unit is a must for peak performance; therefore, a lubricator (preferably a filter/lubricator) should be installed in the airline immediately downstream of the shut-off valve. For best results, use 10W/NR Lube Oil (PN 900082P), available from Elliott Tool Technologies in 16 oz. (0.5 L) cans.

A clean water supply must be provided (preferably city water). Water pressure should not exceed 125 psi (8.6 Bar). A flow rate of at least 30 gpm (114 L/min.) should be available. A shut-off valve should be at the point of connection of the hose whip to the water source. (**IMPORTANT:** Never operate Model 512500 tube cleaner without water supply. Running this tool without water will damage the packing and cause immediate tool failure.)

Hose connection for the water feed hose (supplied) is 1/4" N.P.T.. Connection for the air supply hose (optional) is 1" N.P.T.. The hose used on the 512500 motor for the water feed hose is also the same hose as the air feed hose on the 512500AP air-purge motor.

OPERATING INSTRUCTIONS:

Open the air & water supply valves (air only if air-purge). Holding the motor with the threaded shaft end away from you, slowly depress the trigger lever on the handle (30). The threaded shaft (9) should rotate & water (or air if air-purge) should exit the opening in the threaded shaft. The flow of the water (or air) should increase as the motor R.P.M. increases. If this does not occur, recheck hose connections, or refer to "Troubleshooting" on page 6.

After attaching the motor coupling, the motor shafting, the extension shafting (if req'd.), and the cleaning attachment (drill or brush), insert the shaft into the tube I.D.. (**NOTE: DO NOT** activate the motor while the shaft end is outside the tube. Doing so could result in serious injury.) Maximum length of shafting outside of the tube during the cleaning process is 5 ft. (1.5M).

(**NOTE: If tubes are completely blocked by deposit close to the tube sheet, it is recommended that only a 5 ft. (1.5M) motor shaft be used to clean all of the blocked tubes. Additional 5 ft. (1.5M) shaft extensions can be added for deeper cleaning requirements. Operating the cleaner in completely blocked tubes with a shaft length extending outside of the tube greater than 5 ft. (1.5M) from the tube sheet can result in excessive whipping of the shaft, which could cause serious injury to the operator and/or bystanders.**) If a length of shafting exceeding 5 ft. (1.5M) must be used then support must be provided for the shafting.

(**NOTE: DO NOT support shafting with your hands. Keep hands & clothing clear of rotating shaft & components to avoid serious injury.**) An acceptable means of support for the shafting would be a tube guide that is supported by a height-adjustable stand.

MAINTENANCE

(Refer to pages 7, 8, and 10 for items referenced in instructions listed below)

CARE & MAINTENANCE:

This cleaning motor should give good performance for many hours under extreme load provided that it is supplied with proper lubrication as described in the Operating Instructions on page 4. All rotating parts are mounted on ball bearings, which are either pre-lubricated or get their lubrication from the air stream. The paddles (10) are considered a standard replacement item as they receive the most wear. A loss of power is a strong indication of paddle wear. To replace the paddles, remove the Body Bolt Nuts (40) and the Body Cap Screws (41) and remove the Exhaust End (5). Then remove the Shaft (9), Ball Thrust Bearings (11), and Ball Thrust Plates (12). Inspect the bearings and thrust plates for wear and replace if necessary. Remove the worn paddles and replace with the new set (4 req'd. per set). Reassemble in reverse order. Should this not restore the power to its original state, check "Troubleshooting" on page 6. If solution still cannot be found, motor may have to be returned to the factory for evaluation.

REPAIRS RECOMMENDED TO BE DONE AT THE FACTORY:

1. Excessive leakage of air around the trigger (35) or the unit not shutting off indicates worn O-Ring (32) or worn Trigger Valve Assembly (31).
2. Water leakage around the Shaft (9), or water not shutting off completely, indicates worn O-Rings (21) or worn Water Feed Valve (20).
3. Excessive gear noise with attendant loss of power, due to damaged or worn gears.
4. Motor running rough and causing vibration indicates worn Ball Thrust Bearings (11) and/or Ball Thrust Plates (12).

Please note that the above repairs can be made by the customer, but should be done at a clean work area by someone experienced with repairs of pneumatic motors. Elliott Tool Technologies cannot be responsible for damage to the motor, or its components, when repairs are made by the customer.

Prior to returning the motor to the factory for repairs, contact our Customer Service Group for a Returned Goods (RG) Authorization number. Upon receipt of the motor, an evaluation will be performed, and a cost estimate will be returned to you for approval prior to any actual repairs.

AIR MOTOR TROUBLESHOOTING

	Air Leakage	Air Strainers Clogged	Air Pressure Too Low	Dirty Air	Water In Air	Incorrect Lubrication	Insufficient Lubrication	Hose Too Small	Long Vanes*	Worn Vanes	Rotor Rubbing	Worn Bearing Plates	Worn Valve Seat	Throttle Pin Sticking
Motor Will Not Run		X	X				X		X		X			
Lack Of Power	X	X	X			X		X		X	X	X		
Speed Too Low		X	X					X			X			
High Air Consumption	X									X		X		
Excessive Vane Wear				X		X	X							
Excessive Bearing Wear				X		X	X							
Rusting Of Parts					X	X	X							
Delamination Of Vanes				X	X	X								
Vanes Chipping				X		X	X							
Motor Continues To Run, Throttle Off													X	X

MOTORS:

Pneumatic motors have assemblies built to very close tolerances. Under constant use and with the possibility of foreign parts moving through the air line, these tolerances have a tendency to increase due to vane wear. Air motor maintenance is critical. Dirt should not be allowed to collect around exhaust ports or fitting connections.

***NOTE:** If motor is stored in an area of high humidity, vanes may expand in length.

MOTOR SPECIFICATIONS

Operating Pressure: 90 to 125 psi (6.2 to 8.6 Bar)
 Air Consumption: 135 cfm (5 M³/min) @ 90 psi (6.2 Bar)
 Water Pressure (5125 only): Max. 125 psi (8.6 Bar)
 Water Flow Rate: 30 gpm (114 L/min.)
 Operating Speed: 1600 R.P.M.
 Maximum HP: 2.1HP @ 1500 R.P.M.
 Maximum Torque: 8.3 ft. lbs. (11.3 Nm) @ 700 R.P.M.
 Approximate Wt. (less hose): 35 lbs (15.9 Kg)
 Motor Dimensions: Overall Length = 11" (279.4 mm)
 Across (w/o Handles) = 7.5" (190.5 mm)
 Across (w/ Handles) = 21" (533.4 mm)
 Height = 7.5" (190.5 mm)