

Elliott offers a complete line of precision tube tools, including:



tube expanders

Boiler Expanders
Heat Exchanger Expanders
Condenser Expanders
Refinery Expanders

tube rolling motors & torque controls

Electric
Pneumatic

tube cleaners

Air & Water Driven Motors
(Internal/External Drives)

Jiffy Guns
("Shoot-Thru" Devices)

Roto-Jet
(Rotating Flex Shaft)

additional products

Tube and Joint Testers

Tube Plugs
(High & Low Pressure)

retubing tools

Tube Gauges
Tube Cutters
Manual Tools
Spear Type Tube Pullers
Collet-Type Tube Pullers
CYCLGRIP Tube Extractors
Grooving Tools
End-Prep Tools

metal working products

Back Chamfering Tools
Carbide Roller Burnishing Tools
Diamond Burnishing Tools
Elliptical Deburring Tools
Fine Boring Tools
Internal Recessing Tools
Magic Vise
Mechanical Joining Tools
Roller Burnishing Tools
Single Blade Reamers

"Roto-Jet II"

0650 & 0650R (110V)
0750 & 0750R (220V)



Operating and Maintenance Instructions

Elliott Tool Technologies Ltd • 1760 Tuttle Avenue • Dayton, Ohio 45403 U.S.A.
Phone: +1 800 332 0447 • +1 937 253 6133 • Fax: +1 937 253 9189

Elliott Tool Technologies UK Ltd • Broadstone Hill • Old Chalford • Chipping Norton • OXON • OX7 5QL • England
Phone: +44 (0) 1608 672815 • Fax: +44 (0) 1608 672810

0650R & 0750R PARTS DIAGRAM

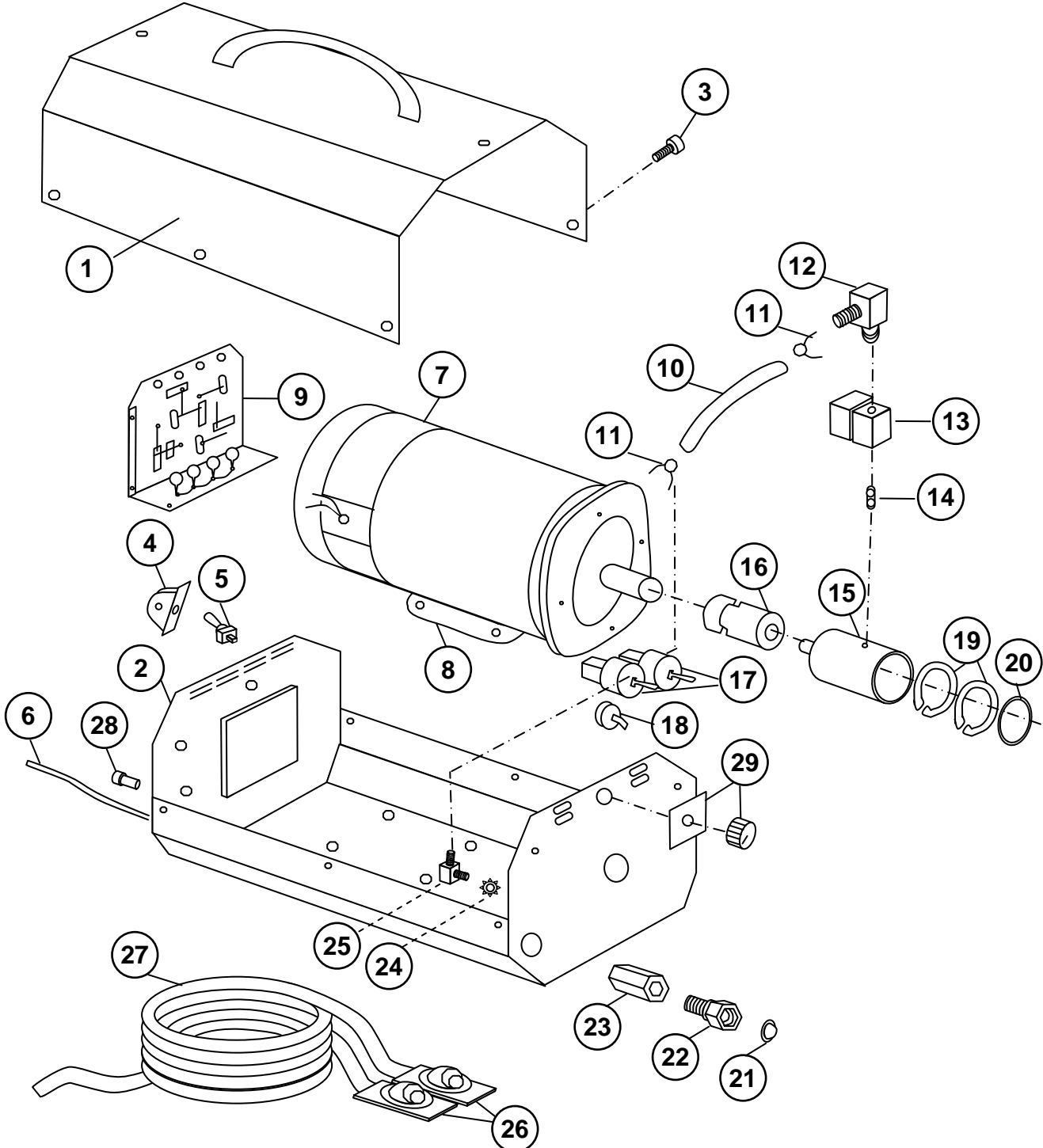

0750R PARTS LIST

ITEM #	PART NAME	PART NUMBER	QTY
1	Cover with Handle	06511702	1
2	Base	06511701	1
3	Cover Screw	06520105	8
4	Switch Guard	06520217	1
5	Switch Assembly	06520120	1
6	Power Cord	07515021	1
7	Motor	06515010	1
8	Mounting Bolt Sets	06520106	4
9	Reversing Circuit Board (220V)	07519174	1
10	Short Water Hose	06550042	1
11	Hose Clamp	06515031	2
12	Barbed Elbow	06550041	1
13	Solenoid Valve (220V)	07511028	1
14	Nipple Connector	06540032	1
15	Manifold with Drive Shaft	06519175	1
16	Motor Coupling	06515011	1
17	Reversing Air Switch	06518131	2
18	Cable Speed Controller	06515004	1
19	Manifold Lock Ring	06519177	2
20	Manifold O-Ring	06518088	1
21	Filter Washer	06520140	1
22	Garden Hose Connector	06520239	1
23	Coupling	06550043	1
24	Washer	06515032	1
25	Barbed Elbow	06550177-2	1
26	Footswitch with Air Tube	06518133	1
27	Air Tube Only	06518122	2
28	Fuse Holder	06515126	1
29	Speed Control Knob	06515002	1

TABLE OF CONTENTS

Introduction	2
Safety	3
Start-up	5
Diagram 1	5
Operation	6
Diagram 2	6
Specifications	7
Maintenance	8
Trouble Shooting Guide	9
Flexible Shaft Repair.....	11
Diagram 3	10
0650 Parts List	12
0750 Parts List	13
0650 & 0750 Diagram	14
0650R Parts List	15
0750R Parts List	16
0650R & 0750R Diagram.....	17

INTRODUCTION

Thank you for purchasing this Elliott product. The design and manufacture of this machine represents the highest standard of quality, value and durability. Elliott tools have proven themselves in thousands of hours of trouble free field operation.

If this is your first Elliott purchase, welcome to our company; our products are our ambassadors. If this is a repeat purchase, you can rest assured that the same value you have received in the past will continue with all of your purchases, now and in the future.

The Elliott Roto-Jet II® is a portable rotary tube brushing machine for cleaning tubes in heat exchangers, condensers, chillers and fire tube boilers.

We at Elliott would like you to be completely satisfied with this machine and therefore recommend that this instruction manual be thoroughly read prior to use.

This machine has been designed and manufactured to the highest standards, using the latest in materials and technology. If the guidelines and maintenance schedules in this manual are followed, the Elliott Roto-Jet II® will provide many years of trouble free operation.

Record your purchase for future reference:

Model No. _____ Serial No. _____ Date of Purchase _____

Elliott Tool Technologies Ltd shall not be liable for errors contained herein or for incidental or consequential damage in connection with the furnishing, performance, or use of this material.

0650R PARTS LIST

ITEM #	PART NAME	PART NUMBER	QTY
1	Cover with Handle	06511702	1
2	Base	06511701	1
3	Cover Screw	06520105	8
4	Switch Guard	06520217	1
5	Switch Assembly	06520120	1
6	Power Cord with GFCI	06515021	1
7	Motor	06515010	1
8	Mounting Bolt Sets	06520106	4
9	Reversing Circuit Board (110V)	06519174	1
10	Short Water Hose	06550042	1
11	Hose Clamp	06515031	2
12	Barbed Elbow	06550041	1
13	Solenoid Valve (110V)	06511028	1
14	Nipple Connector	06540032	1
15	Manifold with Drive Shaft	06519175	1
16	Motor Coupling	06515011	1
17	Reversing Air Switch	06518131	2
18	Cable Speed Controller	06515004	1
19	Manifold Lock Ring	06519177	2
20	Manifold O-Ring	06518088	1
21	Filter Washer	06520140	1
22	Garden Hose Connector	06520239	1
23	Coupling	06550043	1
24	Washer	06515032	1
25	Barbed Elbow	06550177-2	1
26	Footswitch with Air Tube	06518133	1
27	Air Tube Only	06518122	2
28	Fuse Holder	06515126	1
29	Speed Control Knob	06515002	1

0650 & 0750 PARTS DIAGRAM

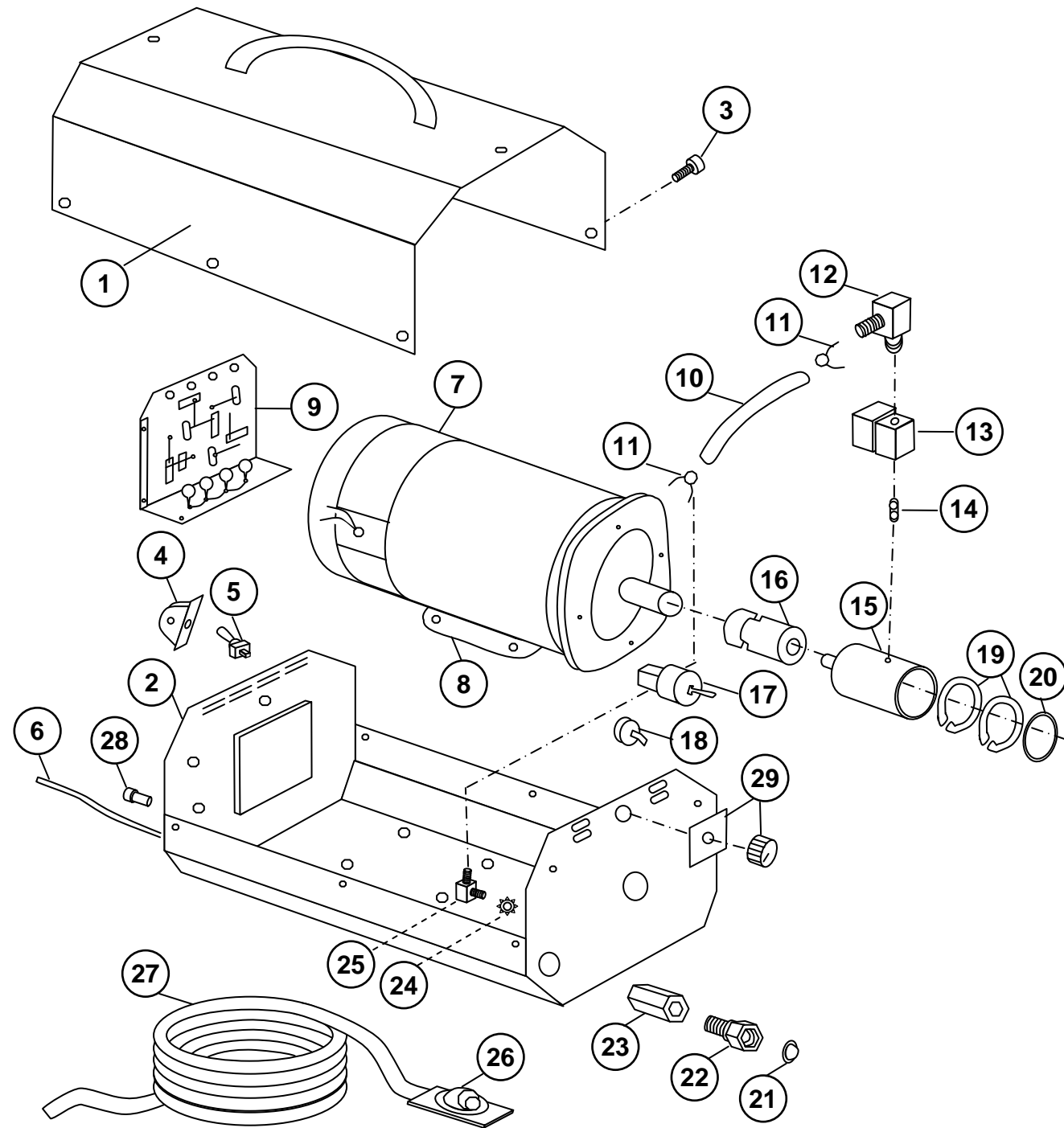



SAFETY



Every effort has been made to ensure the operation of the Elliott Roto-Jet II® is safe, although it is impossible to remove all possibilities of accidents.

It is very important that **all operators** of this machine are fully aware of the following safety considerations.

1. Those unfamiliar with the Elliott Roto-Jet II® should read this operation manual thoroughly before use. Know your equipment. Consider the applications, limitations and the potential hazards specific to your unit.
2. Always wear safety glasses, protective gloves, safety shoes and protective clothing.
3. Do not allow other people in the area of the machine unless they are wearing suitable protective clothing and equipment.
4. Avoid dangerous environments. Do not use your Elliott Roto-Jet II® in or around the presence of explosive atmospheres (gaseous fumes, dust or flammable materials). Remove materials or debris that may ignite.
5. Always use properly grounded electrical outlets. Do not use this machine without a grounded prong.
6. To prevent voltage drop, do not use an extension cord unless absolutely necessary. Then, make certain the cord is or equal rating or larger than the machine power cord.
7. Check power cords before using. Damaged cords can reduce performance or cause a fatal electric shock.
8. Unplug the power cord from the outlet when not in use and prior to doing any tool changes or maintenance. **Do not pull on the cord** to disconnect from the outlet.
9. Avoid accidental starts. Make sure the power switch is in the "OFF" position before plugging the unit into an outlet.
10. To allow free air circulation, the unit should not be covered during operation.
11. Do not operate the machine if there appears to be damage to the machine, if screws are loose or missing, or if performance appears to be unsatisfactory.
12. Never use your Elliott Roto-Jet II®, or any other power tool when under the influence of drugs, alcohol or medication that decreases concentration and impairs operator control.

WARNING

When using electric equipment, always follow basic safety precautions to reduce the risk of fire, electric shock and personal injury.

WARNING

To reduce the risk of injury, always unplug your machine before performing any maintenance. Never disassemble the machine or try to do any rewiring on the electrical system. Contact ELLIOTT for all repairs.

GROUNDING INSTRUCTIONS

This machine must be grounded. If it should malfunction or breakdown, grounding provides a path of least resistance for electric current to reduce the risk of electric shock. This product is equipped with a GFI plug. The plug must be plugged into an appropriate outlet that is properly installed and grounded in accordance with all local codes and ordinances.



DANGER: Improper connection of this equipment-grounding conductor can result in a risk of electrocution. Check with a qualified electrician or service technician if you are in doubt as to whether the outlet is properly grounded. Do not modify the plug provided with this product. If it will not fit the outlet, have a proper outlet installed by a qualified electrician.

G.F.I. PLUG OPERATING INSTRUCTIONS (Not supplied on 220 Volt units.)

1. The GFI plug has been designed to prevent lethal electric shock by interrupting the circuit whenever fault-to-ground occurs.
2. The GFI plug instantly opens the circuit when it senses an imbalance of 4-5 milliamps and it constantly monitors electrical current to a connected load.
3. The GFI plug also offers instant protection from open-neutral conditions that can be created when a break occurs in the neutral conductor or the power source.

WARNING

4. This unit offers **NO** protection against electrical shock hazard resulting from defects or faults in any wiring supplying power to the machine.
5. Ground fault interrupters **DO NOT** protect against electrical shock resulting from contact between hot (line) and common (neutral) conductors of an electrical circuit.
6. If the GFI tests properly without load equipment connected, but trips each time load equipment is connected, then the equipment has a ground fault and needs to be **repaired** or **replaced**. If that condition exists, **DO NOT BYPASS** the GFI as a real shock hazard may be present.
7. The GFI plug is designed for protective purposes, do not utilize it as an On/Off switch.
8. Test the GFI plug before each use to ensure proper operation.

MANUAL RESET

1. Plug the GFI into a 3-wire 120 Volt grounded receptacle.
2. Fully press the reset button marked (marked "R") and release. The unit should power up and the amber "POWER ON" light should glow.
3. Fully press the test button (marked "T") and release. The power light should go off.
4. Press and release the reset button again. Verify that the power light is on and the GFI is now operational.
5. If the GFI fails to reset, or fails to turn off when all appropriate buttons are pressed, check to make sure that:
 - a) You have fully depressed and released the proper buttons.
 - b) There are no loose wire strands or foreign materials in the access chamber of the GFI plug that may cause a fault.
6. If the GFI still cannot complete the cycle described in steps 2 through 4 above and after checking the items in step 5, the unit is not functioning. Contact Elliott for repairs.



WARNING



**To reduce the risk electrical shock, keep connections dry and off the ground.
DO NOT touch the GFI plug with wet hands.**

0750 PARTS LIST

ITEM #	PART NAME	PART NUMBER	QTY
1	Cover with Handle	06511702	1
2	Base	06511701	1
3	Cover Screw	06520105	8
4	Switch Guard	06520217	1
5	Switch Assembly	06520120	1
6	Power Cord	07515021	1
7	Motor	06515010	1
8	Mounting Bolt Sets	06520106	4
9	Circuit Board (220V)	07515001	1
10	Short Water Hose	06550042	1
11	Hose Clamp	06515031	2
12	Barbed Elbow	06550041	1
13	Solenoid Valve (220V)	07511028	1
14	Nipple Connector	06540032	1
15	Manifold with Drive Shaft	06519175	1
16	Motor Coupling	06515011	1
17	Air Switch	06518120	1
18	Cable Speed Controller	06515004	1
19	Manifold Lock Ring	06519177	2
20	Manifold O-Ring	06518088	1
21	Filter Washer	06520140	1
22	Garden Hose Connector	06520239	1
23	Coupling	06550043	1
24	Washer	06515032	1
25	Barbed Elbow	06550177-2	1
26	Footswitch with Air Tube	06518121	1
27	Air Tube Only	06518122	1
28	Fuse Holder	06515126	1
29	Speed Control Knob	06515002	1

0650 PARTS LIST

ITEM #	PART NAME	PART NUMBER	QTY
1	Cover with Handle	06511702	1
2	Base	06511701	1
3	Cover Screw	06520105	8
4	Switch Guard	06520217	1
5	Switch Assembly	06520120	1
6	Power Cord with GFCI	06515021	1
7	Motor	06515010	1
8	Mounting Bolt Sets	06520106	4
9	Circuit Board (110V)	06515001	1
10	Short Water Hose	06550042	1
11	Hose Clamp	06515031	2
12	Barbed Elbow	06550041	1
13	Solenoid Valve (110V)	06511028	1
14	Nipple Connector	06540032	1
15	Manifold with Drive Shaft	06519175	1
16	Motor Coupling	06515011	1
17	Air Switch	06518120	1
18	Cable Speed Controller	06515004	1
19	Manifold Lock Ring	06519177	2
20	Manifold O-Ring	06518088	1
21	Filter Washer	06520140	1
22	Garden Hose Connector	06520239	1
23	Coupling	06550043	1
24	Washer	06515032	1
25	Barbed Elbow	06550177-2	1
26	Footswitch with Air Tube	06518121	1
27	Air Tube Only	06518122	1
28	Fuse Holder	06515126	1
29	Speed Control Knob	06515002	1

START-UP

Unpacking

Your Elliott Roto-Jet II® is shipped in a well-packed carton with the electric supply cord attached and the foot pedal detached. Upon receiving your new machine, inspect the unit for damage. If damage is discovered notify Elliott and the carrier. DO NOT discard the carton or any packaging. Inspectors will need to examine both the carton and the contents.

Connecting Instructions (See diagrams on pages 13 & 15)

1. Uncoil the air tubes that are attached to the foot pedal and insert the air tube into the air port. In the case of a reversing unit, attach the tube of the “right” foot pedal to the “right” barbed air port on the machine and the tube of the “left” foot pedal to the “left” barbed air port.
 2. Uncoil the flexible shaft. **Never operate a flexible shaft that is coiled.** Install the drive coupling onto the flexible shaft. (See diagram 1) Remove the protective cap from the manifold. Make certain the o-ring is properly installed in the groove of the manifold. Insert the drive coupling into the drive socket inside the manifold, tighten the manifold cap onto the manifold. Firm hand tightening will be sufficient.
 3. Connect a standard garden hose to the water inlet on the front of the machine. Make sure the filtered washer is properly installed prior to connecting the water hose. The water supply may be turned on at any time after connection is made, water will not flow through the manifold until the flexible cable is activated.
 4. Select and install the appropriate cleaning attachment to the tool coupling of the flexible shaft.
 5. Uncoil the power cord and plug the GFI plug into a properly wired, grounded outlet.
 6. Move the power switch located on the opposite end of the unit to the “ON” position. Depress the foot pedal to test the operation of the flexible shaft.
- NOTE:** Once the flexible shaft is activated water will begin to flow through the shaft casing and exit at the tool end. Make certain that no water is leaking from the manifold connection or from inside the machine.

Your Elliott Roto-Jet II® is now ready to brush tubes clean.

Diagram 1

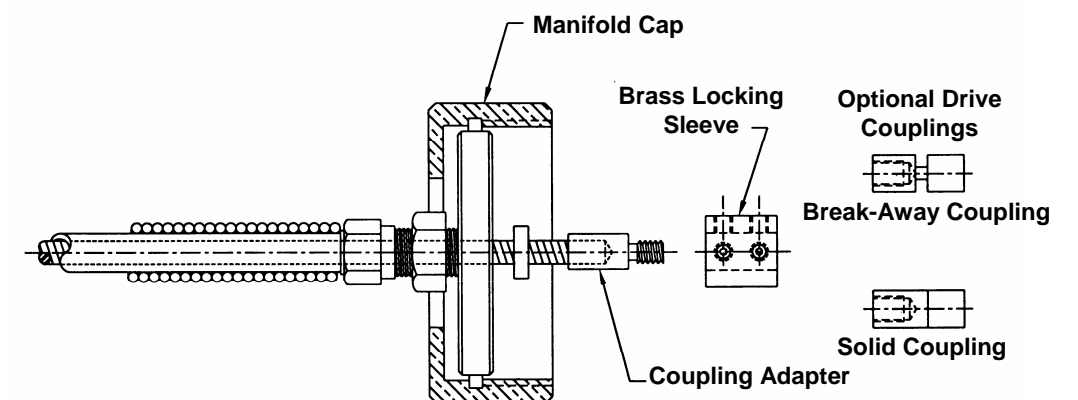

OPERATING INSTRUCTIONS

1. Using your Elliott catalog or the Elliott *Product Selection CD*, select the appropriate flexible shaft and cleaning attachments for the tube size and conditions. Thread the cleaning device into the tool coupling of the flexible shaft.

TOOL TIP

When using a reversing direction drive Roto-Jet II®, install a ¼" lock washer between the tool coupling and the cleaning device. Firmly tighten the connection.

2. DO NOT operate a coiled flexible shaft. Set the Roto-Jet II® at a right angle to the tube sheet of the vessel being cleaned. (See Diagram 2) Position the flexible shaft in a large loop allowing the shaft to enter and exit the tube in a safe radius.
3. Measure the length of the tubes being cleaned. Transfer that measurement to the flexible shaft, from the end of the cleaning device up the flexible shaft casing toward the machine. Mark the casing at that point using electrical tape or a hose clamp snugly tightened on the casing. This is to prevent the cleaning tool from exiting the tube.
NOTE: Allowing the cleaning device to exit the tube while the shaft is spinning will cause the shaft core to fracture, breaking the shaft at that end.
4. Insert the cleaning device into the tube end, start the cable rotation by depressing the footswitch. On the 0650R reversing unit, the "LEFT" footswitch is forward or clockwise direction drive and the "RIGHT" footswitch is reverse or counterclockwise drive.
 - a) Your Roto-Jet II® is equipped with a solid state speed control. This will allow you to adjust the shaft rotation speed from 0 to nearly 1800 RPM.
 - b) We recommend starting at 25% to 50% of the maximum speed for an initial pass down the tube. Evaluate the level of resistance met and adjust the shaft speed to allow the safest and most thorough cleaning speed.
5. Beginning at the top of the vessel, proceed to clean row by row, marking each row as it is cleaned.

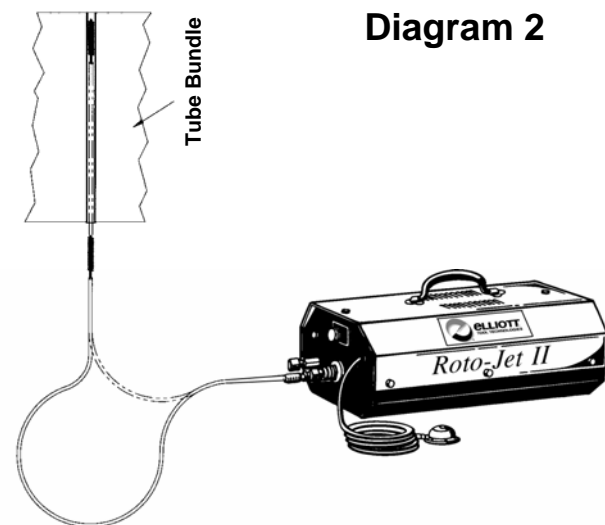

FLEXSHAFT REPAIR

Flexshaft Repair Instructions Instructions for both the Tool and Motor Couplings Using the Elliott Crimping Block Assembly Part Number W900-00

1. Cut the outer casing back approximately 1" for clearance to allow the core to be cleaned up at the break. Grind the end of the core taking care not to overheat the wire strands. Using a hacksaw to square the broken end will cause the wire strands to flex and unwind.
NOTE: The compression fitting on the motor coupling should not be removed from the casing. The excess length of casing is trimmed from the tool coupling end of the flexshaft.
2. Slightly bevel the circumference of the core to remove any burrs.
3. Insert the replacement coupling onto the core. Be sure the core is fully engaged to the full drilled length of the coupling.
NOTE: When replacing the motor coupling, insure that the washer has been placed onto the core before inserting the motor coupling.
4. Locate the assembly of the core and coupling in the proper hole location of the crimping block. Position the assembly in the crimping block with the core end of the coupling, flush with the side of the block.
5. Insert the drive pin in the proper hole above the coupling to be crimped.
6. Strike the pin with a hammer. Care must be taken with this operation, excessive force will deform the coupling and cause the core to distort and unwind.
7. For Flexshaft sizes 0513, 0514 and 0515, rotate the coupling in the crimping block approximately 60° and strike the pin again. Repeat this operation around the coupling. For Flexshaft sizes 0511 and 0512, rotate the coupling in the crimping block approximately 120° and strike the pin again. Repeat this operation around the coupling.
8. The coupling is now secure with equally spaced crimping locations holding the core.

TROUBLE SHOOTING GUIDE

Flexible Shaft coils when cleaning device is inserted into the tube.

- Make sure the flexible shaft is not coiled on the floor but is in a large loop.
- Measure the internal diameter of the tube beyond the expanded portion of the tube end. With the exception of the Elliott Turbo Brush®, cleaning devices should not be sized larger than the tube ID.
- RPM of the flexible shaft and/or the feed rate is too fast.
- Flexible shaft is being forced through a blockage in the tube.
- Examine the flexible shaft for sharp bends or pinch points.

Flexible Shaft prematurely breaks near the drive coupling.

- This may be caused by the shaft being bent at too sharp of a radius.
 - Flexible shaft is too short for the tube being cleaned. Contact Elliott for the correct shaft length.
- NOTE:** The flexible shaft should not be bent at sharp angles. That fractures the shaft core. Use a flexible shaft that is sufficiently long to allow for the cleaning of the entire tube plus enough to comfortably reach the machine on the floor.

Flexible Shaft prematurely breaks at the tool end.

- Flexible shaft is allowed to exit the far end of the tube while the shaft is still rotating.
 - Flexible shaft is being forced through a blockage in the tube.
- NOTE:** Page 6, step 3 described the procedure to mark the flexible shaft casing for the length of tube being cleaned. The purpose for this is to prevent the cleaning device from exiting the far end of the tube. When that does happen the cleaning device whips in as large a radius as it can which results in fracturing the shaft core leading to breakage.

Below and on the next page is the procedure for repairing broken flexible shafts in the field.

Diagram 3

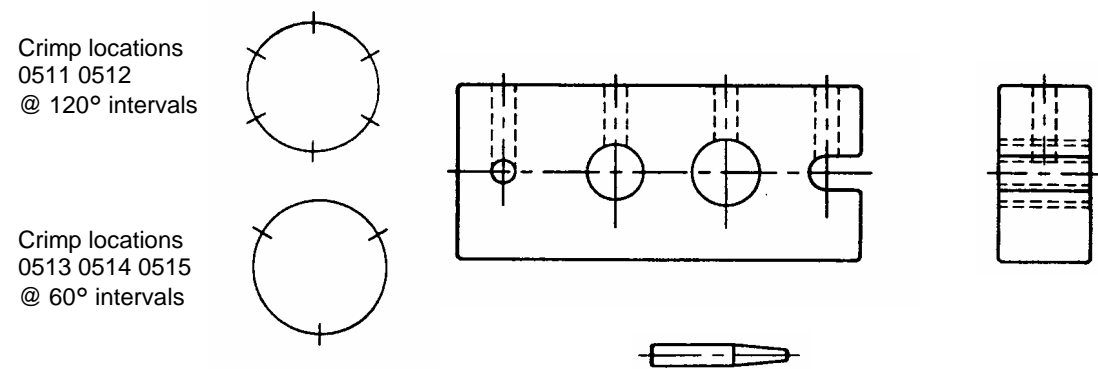

SPECIFICATIONS

0650 & 0650R	
Motor	1/2 HP DC Motor
Power Supply	115 Volt / 50-60 Hx 6 Amps
Fuse	10 Amp
Shaft Speed	0 to 1800 RPM Adjustable
Dimensions	22" L x 11" W x 10" H
Weight	35 lbs.
Water Input	Garden Hose

0750 & 0750R	
Motor	1/2 HP DC Motor
Power Supply	220 Volt / 50-60 Hx 6 Amps
Fuse	10 Amp
Shaft Speed	0 to 1800 RPM Adjustable
Dimensions	22" L x 11" W x 10" H
Weight	35 lbs.
Water Input	Garden Hose

MAINTENANCE

Before Each Use

- 1) Inspect your Roto-Jet II® for any obvious damage or missing parts.
- 2) Check the power cord for cracks or wear.
- 3) Test the GFI plug to insure proper functioning.
- 4) Inspect the manifold o-ring. Replace if necessary.
- 5) Make sure the filter washer is in place and clean.
- 6) Inspect the foot switch air hose(s) for damage.
- 7) Check the fuse, replace if necessary.
- 8) Tighten all screws and bolts.
- 9) Make sure all the vents cut in the machine casing are clear.
- 10) Briefly test run your Roto-Jet II®.
 - a) If abnormal noise or vibration occur, turn the machine off immediately.
 - b) See the "Trouble Shooting" section to diagnose the problem and correct the problem before further use.

After Each Use

- 1) Disconnect the flexible shaft from the unit and drain the water from the casing.
- 2) Spray a water displacement solution such as WD-40 into the casing from both ends, allowing the solution to run the entire length of the shaft.
- 3) Coil the flexible shaft in a large diameter coil and tie it with the supplied Velcro strap.
- 4) Disconnect the footswitch and safely store.
- 5) Coil the power cord and tie together.

Long Term Storage

- 1) Drain excess water from the flexible shaft casing.
- 2) Generously spray a water displacement solution such as WD-40 into the casing from both ends, allowing the solution to run the entire length of the shaft.
- 3) Store the flexible cable in large diameter coil and tie them with the supplied Velcro strap.
- 4) To prevent freezing or other resultant damage, clear the manifold of water.
 - a) Activate the solenoid by depressing the foot switch.
 - b) Force compressed air through the garden hose fitting. The air will remove most of the water from the manifold.
- 5) Disconnect the foot switch and safely store.
- 6) Coil the power cord and tie together.
- 7) Safely store the Roto-Jet II® and the accessory items for the next cleaning season.

TROUBLE SHOOTING GUIDE

Machine will not start when foot switch is depressed.

- The non-electrical footswitch operates an air valve. Let the pedal up and depress again more quickly.
- Make sure the air tube(s) of the footswitch is fully inserted in the air port(s).
- Examine the air tube(s) for damage or pinching.
- Make sure unit is plugged in and the power switch is in the "ON" position.
- Push the Reset Button on the GFI plug at the outlet. CAUTION: Make sure hands are dry.
- Check the fuse in the machine.
- Examine the power cord for damage.

Machine rotates but no water is flowing from the flexible cable casing.

- Check the water inlet hose connection.
- Check the water hose for kinks.
- Examine the filter for debris.
- Make sure the water supply is on and there is enough volume.

Water is leaking from the machine.

- Disconnect the flexible shaft from the manifold, make sure the o-ring is in place and undamaged.
- Remove the cover of the machine, make sure the "short water hose" is properly connected.
- Water leaking from the manifold indicates the seals are damaged. Replace the manifold.

Machine makes unusual noise or vibrates when operated.

- Check for loose or missing cover screws.
- Remove cover and check for loose or missing motor mounting bolts.
- Check the alignment of the motor drive shaft and the cable drive shaft.
- Check the position and tightness of the motor-to-manifold coupling.

Flexible Shaft stops rotating.

- Disconnect the flexible shaft from the manifold and examine the breakaway coupling.
- Make sure the drive coupling is fully inserted into the drive socket.
- Examine each end of the flexible shaft core for breakage.
- Remove the cover of the machine, examine the motor-to-manifold coupling making sure it is firmly connected to the motor drive shaft and the manifold drive shaft and that coupling ends are properly connected together.