

Elliott offers a complete line of precision tube tools, including:



**tube  
expanders**

- Boiler Expanders
- Heat Exchanger Expanders
- Condenser Expanders
- Refinery Expanders

**tube rolling motors  
& torque controls**

- Electric
- Pneumatic

**tube  
cleaners**

- Air & Water Driven Motors  
(Internal/External Drives)
- Jiffy Guns  
("Shoot-Thru" Devices)
- Roto-Jet  
(Rotating Flex Shaft)

**additional  
products**

- Tube and Joint Testers
- Tube Plugs  
(High & Low Pressure)

**retubing  
tools**

- Tube Gauges
- Tube Cutters
- Manual Tools
- Spear Type Tube Pullers
- Collet-Type Tube Pullers
- CYCLGRIP Tube Extractors
- Grooving Tools
- End-Prep Tools

**metal working  
products**

- Back Chamfering Tools
- Carbide Roller Burnishing Tools
- Diamond Burnishing Tools
- Elliptical Deburring Tools
- Fine Boring Tools
- Internal Recessing Tools
- Magic Vise
- Mechanical Joining Tools
- Roller Burnishing Tools
- Single Blade Reamers

**"TUBE-TUGGER®"**  
Continuous Tube Extractor  
For 5/8" – 1-1/4" Tube OD  
(80-40125)



**Operating and Maintenance Instructions**



[www.elliott-tool.com](http://www.elliott-tool.com)

Elliott Tool Technologies Ltd • 1760 Tuttle Avenue • Dayton, Ohio 45403 U.S.A.  
Phone: +1 800 332 0447 • +1 937 253 6133 • Fax: +1 937 253 9189

Elliott Tool Technologies UK Ltd • Broadstone Hill • Old Chalford • Chipping Norton • OXON • OX7 5QL • England  
Phone: +44 (0) 1608 672815 • Fax: +44 (0) 1608 672810

# TOOL SELECTION CHART

Tube O.D.	Wall Gage	Nose Piece	Collet Set	O-Ring	Pulling Spear	Spear Male Square Size	Adapter From Spear Sq. To 3/4" Female Drive Sq.
5/8"	13-16	80-40125N062	80-40125C062	P8309-225	TR625-13	1/2"	71SOCT
	18-24				TR625-18		
3/4"	10-12	80-40125N075	80-40125C075		TR750-10	5/8"	71SOCB
	13-16				TR750-13		
	18-24				TR750-18		
7/8"	10-12	80-40125N087	80-40125C087		TR875-10		
	13-16				TR875-13		
	18-24				TR875-18		
1"	10-12	80-40125N100	80-40125C100		TR1000-10	3/4"	71SOC
	13-16				TR1000-13		
	18-24				TR1000-18		
1-1/4"	10-12	80-40125N125	80-40125C125		TR1250-10	1"	71SOMC
	13-16			TR1250-13			
	18-24			TR1250-18			

Above spears are standard. Additional gauges and lengths available upon request.

## SPECIFICATIONS

<b>Tube-Tugger Specifications</b>		
	<b>Inch</b>	<b>Metric</b>
<b>Standard Tube OD Range</b>	5/8" To 1-1/4"	16mm To 31.7mm
<b>Cylinder Capacity</b>	30 Tons	
<b>Length (Includes Nose Piece)</b>	15"	380mm
<b>Diameter</b>	6"	152mm
<b>Weight</b>	40#	18 kg
<b>Stroke</b>	3"	76mm
<b>Hydraulic Oil Type</b>	ISO 32 Grade	

## RECOMMENDED PUMP

Catalog Number	Pump Type	HP	Maximum Operating Pressure		Power Requirement	Weight	
			PSI	Bar		Lbs	Kg
M5773-00	115 Volt w/Pendant	1.13	10,000	700	25 amps @ 115V	88	39.95
M5775-00	*Pneumatic w/Pendant	3	10,000	700	50 cfm @ 80 psi	91	41.31
M5776-00	230 Volt w/Pendant	1.13	10,000	700	15 amps @ 230V	88	39.95
80-36102D3	Hand Pump	-	10,000	700	-	28	12.7

\*Includes 6070 Filter / Lubricator

# TOOL CHANGEOVER

## Changing The Nosepiece:

1. Loosen socket screws in nosepiece adapter with Allen wrench.
2. Remove nosepiece from nosepiece adapter.
3. Insert new nosepiece into nosepiece adapter.
4. Make sure that the socket screw engages into slotted ring of the nosepiece.
5. Tighten socket screw to lock in nosepiece.

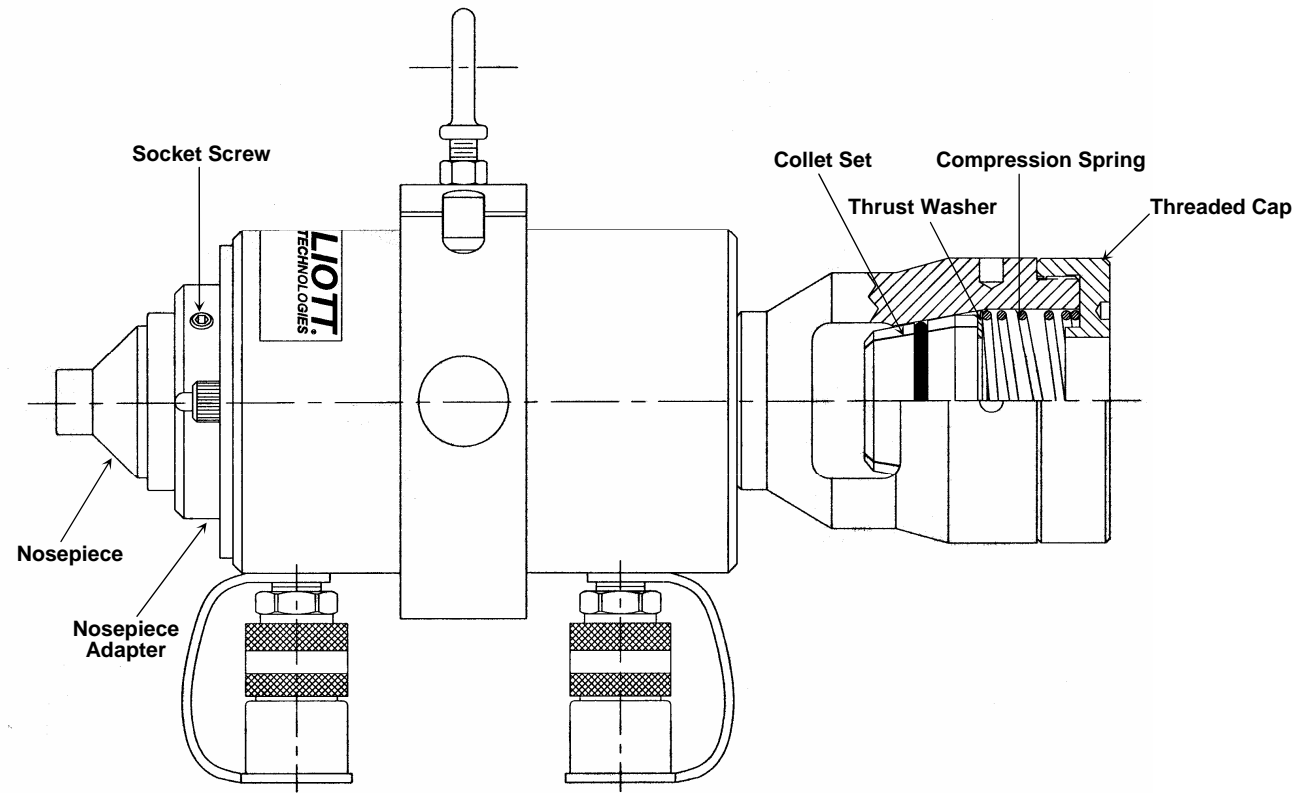

Diagram E

## Changing The Collet Set:

1. Engage spanner wrench into threaded cap and loosen cap.
2. Unthread cap from rear of Tube-Tugger.
3. Remove compression spring and thrust washer.
4. Remove set of collet jaws from Tube-Tugger.
5. Lubricate new set of collet jaws on the OD of the jaws.
6. Insert new set of collet jaws into Tube-Tugger.
7. Insert thrust washer and compression spring.
8. Thread cap onto Tube-Tugger.
9. Secure cap firmly using spanner wrench and release fork.

# TABLE OF CONTENTS

Introduction .....	2
Safety .....	3
Start-up .....	4
Quick Reference Diagram.....	5
Operation .....	6-7
Tool Changeover .....	8
Tool Selection Guide / Specifications .....	9

# INTRODUCTION

Thank you for purchasing this Elliott product. The design and manufacture of this machine represents the highest standard of quality, value and durability. Elliott tools have proven themselves in thousands of hours of trouble free field operation.

If this is your first Elliott purchase, welcome to our company; our products are our ambassadors. If this is a repeat purchase, you can rest assured that the same value you have received in the past will continue with all of your purchases, now and in the future.

The Elliott Tube-Tugger<sup>®</sup> is a portable continuous tube extractor for removing or extracting tubes from heat exchangers, condensers and chillers. This tube extractor is hydraulically driven and powered by a separate hydraulic power source: Manual, electric or pneumatic.

We at Elliott would like you to be completely satisfied with this machine and therefore recommend that this instruction manual be thoroughly read prior to use.

This machine has been designed and manufactured to the highest standards, using the latest in materials and technology. If the guidelines and maintenance schedules in this manual are followed, the Elliott Tube-Tugger will provide many years of trouble free operation.

Elliott Tool Technologies Ltd shall not be liable for errors contained herein or for incidental or consequential damage in connection with the furnishing, performance, or use of this material.

Diagram D

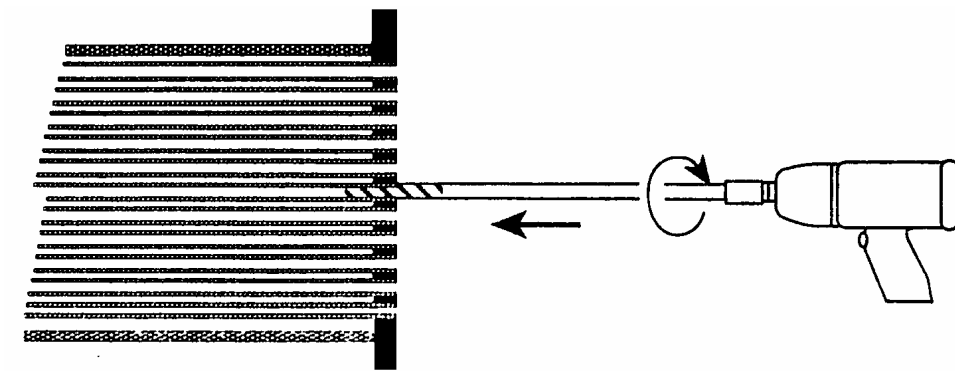

Spear being impacted into tube.

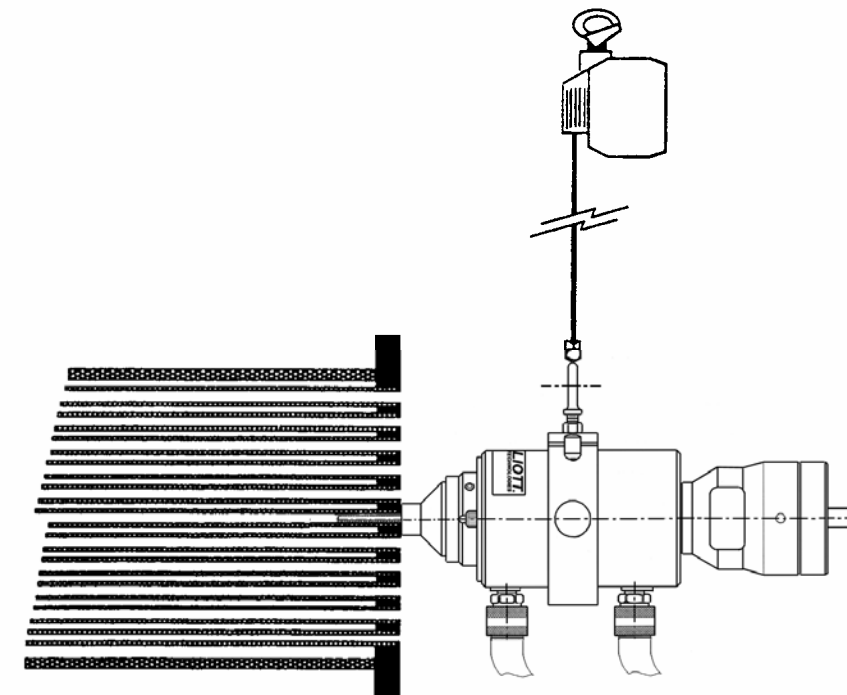

Tube-Tugger secured to counter balance and positioned over the spear.

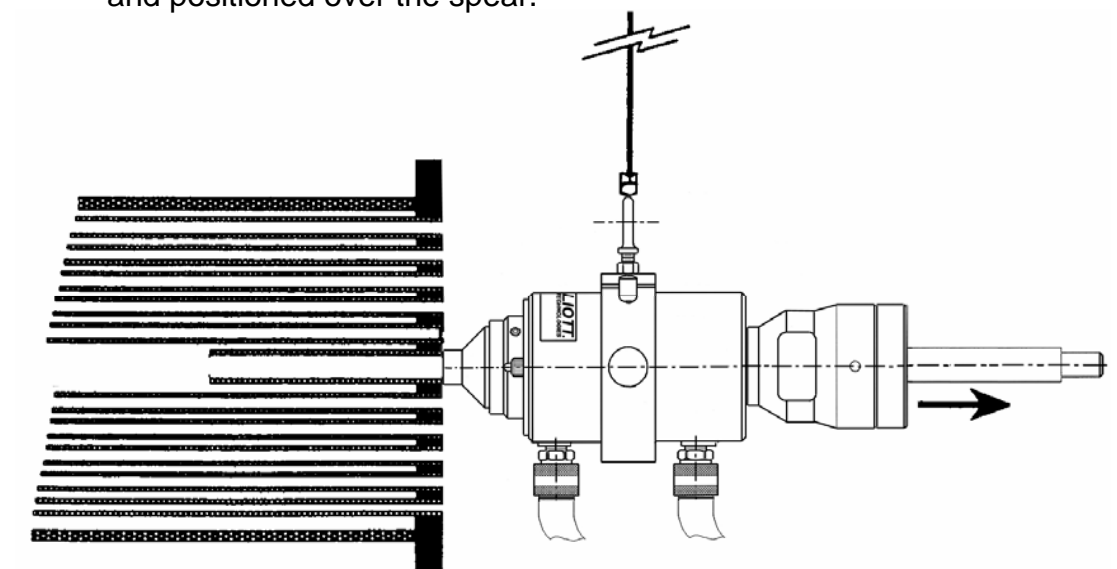

Tube-Tugger in operation.

# OPERATION

The Tube-Tugger has been designed for efficient use and optimum productivity. The unit is small, lightweight and portable.

The Tube-Tugger will extract tubes with outside diameters ranging from 5/8" to 1-1/4". Standard OD collet jaws and nosepieces are available for 5/8", 3/4", 7/8", 1" and 1-1/4" OD tubes.

Pulling spears are sized for the tube ID. Twenty-five standard spear sizes are available.

The tool selection guide for the Tube-Tugger is listed on page 9.

1. Determine the OD and ID of the tubes to be extracted.
2. Select the proper tools: Nosepiece, pulling spear and collet set (See Page 9).
3. Install the correct nosepiece and collet set on the Tube-Tugger.
4. Thread the spear into the tube ID using adapter with an impact drive or by hand.  
NOTE: Be careful not to impact the spear too deep, as this will cause difficulty in extracting the tubes.
5. Secure Tube-Tugger to counter balance.
6. Position the Tube-Tugger over the spear and hold against the tube sheet.
7. Initiate the stroke of the Tube-Tugger. When the Tube-Tugger has reached its maximum stroke, initiate the return stroke, keeping the Tube-Tugger in contact with the tube sheet. Repeat until the tube end is visible from the back end of the collet holder.
8. Once the spear has passed through the collet jaws, stop the Tube-Tugger and remove the spear from the tube.
9. Continue the extraction until the tube is fully extracted from the vessel. Once the tube is pulling freely the operator may hand pull the tube through the collet jaws to speed up the extraction process.  
NOTE: The release fork may be used to fully open the collet jaws if required.
10. Repeat steps 4 to 9 until all tubes are extracted.

# SAFETY

Every effort has been made to ensure the operation of the Elliott Tube-Tugger is safe, although it is impossible to remove all possibilities of accidents.

It is very important that **all operators** of this machine are fully aware of the following safety considerations.

1. If you are unfamiliar with the Elliott Tube-Tugger, read this Operation Manual thoroughly before use.
2. Always wear safety glasses, protective gloves, safety shoes and protective clothing.
3. Do not allow other people in the area of the machine unless they are wearing suitable protective clothing and equipment.
4. As the machine is hydraulically driven, hydraulic oil leaks from the ram and hose connections are possible. If hydraulic oil is leaked, clean-up oil immediately to avoid slippery floor surfaces.
5. The Elliott Tube-Tugger stroke is controlled by a manual control on the hydraulic power source. It is important to read and understand the manual for the hydraulic power source.
6. Ensure all hydraulic connections are properly made and that the hydraulic hoses are in good condition.
7. Always be aware of hydraulic power shut off valve.
8. Always shut down the hydraulic power supply before changing tooling.
9. Do not operate the machine if there appears to be damage to the machine, if screws are loose or missing, or if performance appears to be unsatisfactory.
10. Never use the Tube-Tugger, or any other power tool when under the influence of medication, drugs or alcohol that decrease concentration and impair operator control.

# START-UP

## Unpacking

The Elliott Tube-Tugger is shipped in a carton complete with all accessories listed. On arrival, check for external damage to the box. If damage is found, notify the carrier and the supplier so insurance inspectors can examine the box before it is unpacked. When opened, check the contents against the packing and parts list. Report any damage or shortage to Elliott.

Ensure that there is no packaging material left inside the openings of the machine, especially in the hydraulic inlets.

## Connecting to Hydraulic Power Supply

The Elliott Tube-Tugger requires a hydraulic power source. The hydraulic power source supplied by Elliott will be an electric, pneumatic or manual pump.

1. Position the Tube-Tugger and the hydraulic power source on a flat surface.
2. Connect counter balance eye bolt and fasten operator side handles.
3. Connect the two 15' hydraulic hoses to both units. **Important: Make sure that the male hose fittings are totally in contact with female fitting shoulder on the tube pulling cylinder before threading down the locking fitting. Otherwise the cylinder's relief valve will activate and release a fog of hydraulic fluid and the cylinder will remain idle.**
4. Follow the directions of the Elliott hydraulic pump manual to assure that hydraulic pump is working properly.
5. Cycle the Tube-Tugger several strokes to eliminate any air in the hydraulic lines.  
NOTE: The hydraulic hoses are pre-charged with oil by the factory.
6. The Tube-Tugger is ready for tool installation.

## Removing the Hydraulic Hoses

1. Neutralize the pressure before removing the hydraulic hoses.  
NOTE: On the hydraulic power units with remote control, flip the switch on the top of the hydraulic pump from "Remote" to "Off". Cycle both "Advance" and "Retract" switches on the remote control, to neutralize the pressure.

# QUICK REFERENCE DIAGRAMS

