

0420 Roto-Jet™ Cleaning System



Tube & Pipe Cleaners ◦ Tube Testers ◦ Tube Plugs ◦ Tube Removal ◦ Tube Installation

Operating and Maintenance Instructions

Table Of Contents

Introduction	4
Safety	5
Operation.....	7
Operating Position (Diagram A)	8
Drive Coupling (Diagram B)	10
Air Supply Requirements.....	12
Maintenance.....	13
Technical Data	15
Trouble Shooting Guide.....	17
Records	20 & 21
Flexshaft Repair	24

INTRODUCTION

Thank you for purchasing this Elliott product. More than 100 years of experience have been employed in the design and manufacture of this control, representing the highest standard of quality, value and durability. Elliott tools have proven themselves in thousands of hours of trouble free field operation.

If this is your first Elliott purchase, welcome to our company; our products are our ambassadors. If this is a repeat purchase, you can rest assured that the same value you have received in the past will continue with all of your purchases, now and in the future.

The Elliott Roto-Jet has been designed for cleaning tubes in the following types of equipment:

Heat Exchangers

Condensers

Chillers

If you have any questions regarding this product, manual or operating instructions, please call Elliott at +1 800 332 0447 toll free (USA only) or +1 937 253 6133, or fax us at +1 937 253 9189 for immediate service.

SAFETY

Read and save all instructions. Before use, be sure everyone using this machine reads and understands this manual, as well as any labels packaged with or attached to the machine.

1. Know Your Elliott Roto-Jet™. Read this manual carefully to learn your tool's applications and limitations, as well as potential hazards, associated with this type of equipment.
2. Keep Work Area Clean and Well Lighted. Cluttered, dark work areas invite accidents.
3. Dress Properly. Do not wear loose clothing or jewelry. Wear a protective hair covering to contain long hair. It is recommended that the operator wear safety glasses with side shields or a full face shield eye protection. Gloves and water repellant, nonskid footwear are also recommended. Keep hands and gloves away from moving parts.
4. Use Safety Equipment. Everyone in the work area should wear safety goggles or glasses with side shields complying with current safety standards. Wear hearing protection during extended use, respirator for a confined space and a dust mask for dusty operations. Hard hats, face shields, safety shoes, respirators, etc. should be used when specified or necessary.
5. Keep Bystanders Away. Bystanders should be kept at a safe distance from the work area to avoid distracting the operator and contacting the flexshifting or machine. Only the operator of the machine should engage the foot switch control. NEVER PLACE A WEIGHTED OBJECT ON THE FOOT SWITCH TO PRODUCE CONTINUOUS OPERATION OF THE MACHINE.
6. Protect Others in the Work Area from debris such as water exhaust and water spray. Provide barriers or shields as needed.
7. Use the Right Cleaning Device. Do not use a cleaning device or attachment to do a job for which it is not recommended. Refer to the Elliott E-100 catalog for all optional equipment. Do not alter the machine or cleaning device, this will void the warranty on the product.
8. Use Proper Accessories. Use Elliott accessories only. Be sure accessories are properly installed and maintained. Do not defeat a guard or other safety device when installing an accessory or attachment.
9. Check for Damaged Parts. Inspect guards and other parts before use. Check for misalignment, binding of moving parts, improper mounting, broken parts or any other conditions that may affect operation. If abnormal noise or vibration occurs, turn the machine off immediately and have the problem corrected before further use. Do not use a damaged machine. Tag damaged machines "Do Not Use" until repaired. A guard or other damaged part should be properly repaired or replaced by an Elliott service facility. For all repairs, insist on only identical replacement parts.
10. Remove All Wrenches. Check that all accessory wrenches are removed from the system before turning it on.
11. Avoid Accidental Starting. Be sure your machine is turned off before supplying air pressure. Do not use a machine if the foot control switch is not turning the machine on and off. NEVER USE ANY OBJECT TO HOLD THE FOOT SWITCH IN THE "ON" POSITION.
12. Do Not Force the Flexshaft. Your Elliott Roto-Jet™ will perform best at the rate for which it was designed. Excessive force only causes operator fatigue, increased flexshaft wear, shaft or break-away coupling failure.
13. Keep Hands Away from All Moving Parts.
14. Do Not Overreach - Maintain Control. Keep proper footing and balance at all times.

15. Stay Alert. Watch what you are doing, and use common sense. DO NOT use a machine when you are tired, distracted or under the influence of drugs, alcohol or any medication causing decreased control.
16. Remove the Air Supply to the Machine when it is not in use, before changing accessories or when performing recommended maintenance.
17. Maintain Machine Carefully. Keep handles dry, clean and free from oil and grease. Follow instructions for lubricating and changing accessories. For more information see "Maintenance" section. Periodically inspect the machine and air supply hose for damage. Have damaged parts repaired or replace by an Elliott service facility.
18. Store Idle Machines. When not in use, store your machine in a dry, heated, secured place. For more information see "Maintenance" section.
19. Maintain Labels and Nameplates. These carry important information and will assist you in ordering spare and replacement parts. If unreadable or missing, contact an Elliott service facility for a replacement.
20. Stop the Machine Immediately if the Flexshaft Starts to Coil. Flexshaft damage will occur if flexshaft is operated in a coiled position.
21. Use the Proper Flexshaft to fit the tubes to be cleaned. Never use a flexshaft that is too small or too short. Flexshaft failure will result if too great a resistance is placed on the flexshaft. Refer to the chart below for sizing information. (See Fig. 1 and 2)

Wet Shafts (Fig.1)				
Prefix Part Number	Casing Outside Diameter		Tube Inside Diameter	
	inch	mm	inch	mm
0511*(xx)	.250	6	5/16 - 3/8	8 - 10
0512*(xx)	.375	10	7/16 - 1/2	11 - 13
0513*(xx)	.500	13	9/16 - 1	14 - 25
0514A*(xx)	.625	16	3/4 - 1-1/2	19 - 38
0514*(xx)	.750	19	1 - 2	25 - 50
0515*(xx)	1.000	25	2 and over	50 and over

*Length of shaft in feet completes the part number.
 (Available in standard lengths of 16', 25', 33', and 49'. Consult factory for additional lengths.)

Dry Shafts (Fig.2)				
Prefix Part Number	Casing Outside Diameter		Tube Inside Diameter	
	inch	mm	inch	mm
0534*(xx)	7/8	22	1 and over	25 and over

*Length of shaft in feet completes the part number.
 (Available in standard lengths of 25', 35', and 50'. Consult factory for additional lengths.)

OPERATION

Correct Machine Position and Operation is critical to getting the job done quickly and efficiently. This can be accomplished by the following these steps:

Examine the tubes to be cleaned and measure the internal diameter (Elliott Tube Gauge is recommended) and length of the tubes. If the tube ends are expanded, then make a note of the smallest internal diameter. Record these measurements on the chart provided in the back of this manual. You will need these measurements to select the proper size flexshaft and cleaning attachments.

TOOL TIP

Always select a smaller size of cleaning device for heavy tube deposits. With the exception of the Elliott Turbo Brush, never use a brush or cleaning device larger than the internal diameter of the tubes.

Carry the machine to the location where the cleaning will take place.

Position the machine at a right angle to the tube sheet or cleaning area. This will keep the flexshaft at the proper radius. **NEVER OPERATE THE MACHINE IN THE VERTICAL POSITION.** (See Diagram A).



WARNING

This machine requires oil lubrication mixed with the air supply. When using the machine in a confined space, the operator must wear proper eye protection and use a breathing apparatus capable of filtering airborne oil particles.

DIAGRAM A

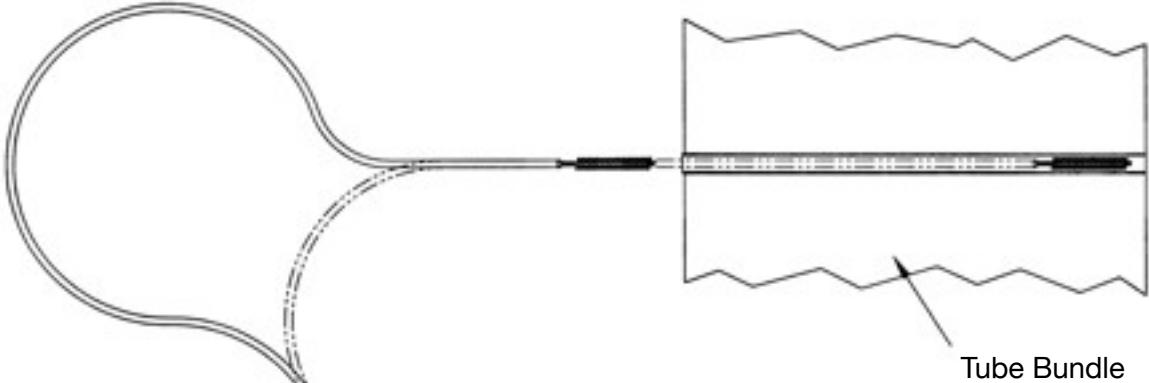

TOP VIEW

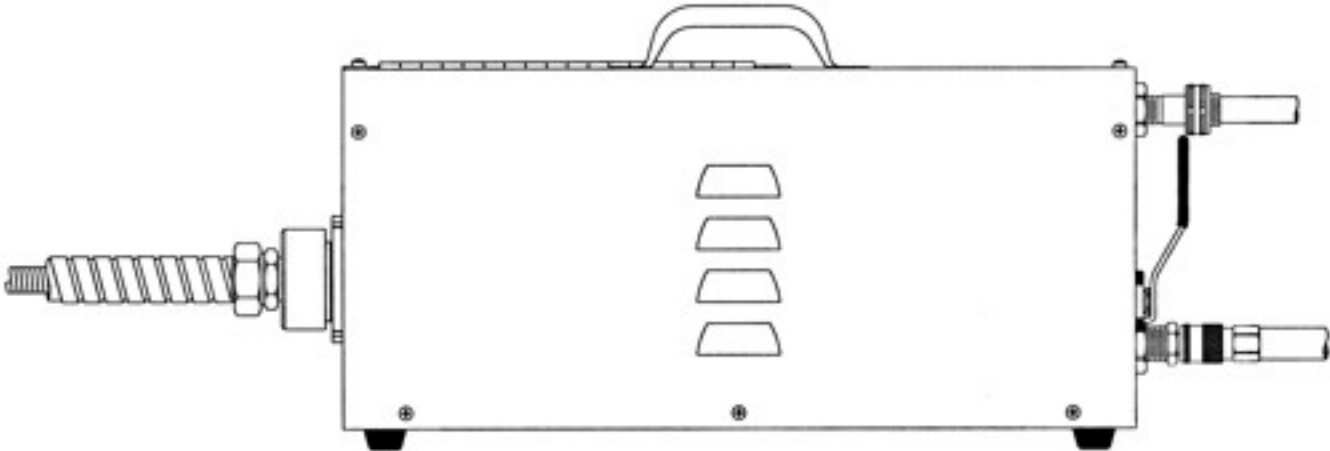
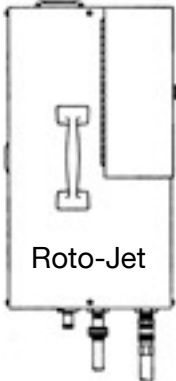

CORRECT OPERATING POSITION

OPERATION (CONT.)

Open the foot switch storage compartment and remove the foot switch, “O” ring, rubber hose washer and the air hose “quick disconnect” fitting.

Position the foot switch hose in the cutout provided before closing compartment lid.

Install the quick disconnect to an air hose capable of withstanding 100 psi (6.89 Bar-Metric). The hose should have an inside diameter of 1/2” (13mm).

Place the rubber hose washer in the water hose connection of the machine. This is a one time operation. The rubber washer can remain in this connection and does not require removal after use.

Connect a standard garden hose to the 3/4” water hose connection of the machine. The machine is designed for “Municipal” water pressure only, Max 100 psi (6.89 Bar-Metric). DO NOT connect the water connection to a “High Pressure” source. Water is important to the cleaning process as it flushes away deposits cleaned from the tube and helps to lubricate and cool the flexshaft.

Position the “O” ring in the recess of the flexshaft connection manifold.

Prepare the flexshaft by loosening the four (4) set screws located in the brass locking sleeve using a 3/32” Allen wrench. Thread the breakaway or solid square drive into the coupling adapter that is swaged on the core of the flexshaft. Position the brass locking sleeve equally over the coupling adapter and the breakaway or solid square drive. Firmly tighten the four (4) Allen set screws. (See Diagram B page 8)

Insert the square drive into the manifold of the machine. Rotate the flexshaft by hand to properly seat the square drive of the flexshaft into the manifold. Thread the brass manifold cap onto the manifold of the machine and firmly hand tighten.

Attach the chosen cleaning device to the tool coupling swaged to the core of the flexshaft at the opposite end from the manifold connection and firmly tighten the device. Connect the appropriate air pressure source to the machine. For more information see “Air Supply” section.

Turn on the water supply.

Layout the flexshaft as straight as possible. DO NOT start the machine with the flexshaft in a coiled position.

Depress the foot switch. Move the throttle valve located next to the air supply connection slowly until the air motor starts to turn the flexshaft. Adjust this valve to the desired RPM for the cleaning device and flexshaft being used. At the same time, water will pass through the machine and out the end of the flexshaft casing near the cleaning device. Remove your foot from the foot switch and both the water and rotation of the shaft will stop. Restart the machine and observe the water output from the end of the flexshaft casing. A constant stream of water should be discharged from the casing as the core rotates. If no water is discharged from the flexshaft, check the hose and hose connection for any “kinks” that would restrict water flow. Depress the foot switch again and observe the water flow from the end of the flexshaft. If no water is discharged, discontinue use of the machine and contact an Elliott service facility.

DIAGRAM B

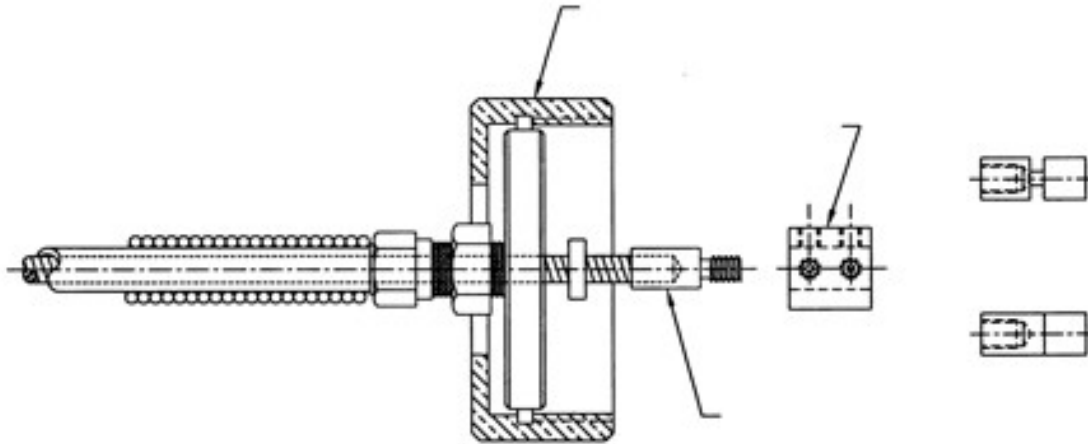

TOOL TIP

Operate the flexshaft as straight as possible to minimize any sharp radius bends. This applies to both brush insertion and at maximum cleaning length. Operating the flexshaft in a constant sharp radius will flex fatigue the wires in the core reducing its strength. Allowing the cleaning device to exit the tube while rotating can cause premature shaft failure in the tool coupling area. Never exit the tube with the tube cleaning device in operation. For more information see “Technical” section.

TOOL TIP

Measure the length of the tubes being cleaned from the tube sheet to the tube sheet at the opposite end. Transfer this measurement to the flexshaft from the END of the cleaning device up the casing toward the machine. Mark the end of the measurement on the casing by wrapping the point with electrical tape. This will enable you to feed the flexshaft through the tube and stop the cleaning device before exiting the tube on the opposite end.

TOOL TIP

Start to clean the tube bundle from the top of the unit to the bottom. Clean the bundle one row at a time, marking with soapstone, each row of tubes that have been cleaned.

OPERATION (CONT.)

The machine is now ready to operate.



WARNING

This machine drives high speed, rotating cleaning devices. It is recommended that the operator wear safety glasses with side shields or full face shield eye protection, gloves and water repellent, nonskid foot wear. Avoid contact with objects other than the tube when the machine is in operation.

Hold the end of the flexshaft with your hand about 12" (304.8mm) back from the cleaning device. Insert the cleaning device just inside the tube to be cleaned and hold the flexshaft away from your body. Depress the foot switch and start to feed the flexshaft down the tube.

It is important that the flexshaft not be forced down the tube. If you meet resistance, proceed at a slower pace or refit the flexshaft with a smaller cleaning device. Should the flexshaft meet too much resistance it will begin to coil.



WARNING

DO NOT ALLOW THE FLEXSHAFT TO COIL. Coiling of the flexshaft could cause binding within the casing and shear the core material. If a blockage is encountered, and the shafting begins to coil, immediately stop feeding the shafting into the tube and start drawing the shafting back until coiling stops. Then proceed to slowly feed the flexshafting into the tube, being sure to draw the shafting back when blockage is encountered and coiling begins. Follow this procedure until the cleaning device removes the blockage.



WARNING

DO NOT FORCE FLEXSHAFT THROUGH A TUBE BLOCKAGE. If an obstruction is discovered or in case of high deposit build-up, reduce the rate of feed on the flexshaft and allow cleaning device additional time to clear the blockage. Applying more torque to attempt to break through heavy deposits could result in damage to the flexshaft.

AIR SUPPLY

Your Elliott Roto-Jet™ has been designed to require a maximum air pressure of 125 P.S.I. (8.62 Bar-Metric).

An automatic air line filter-lubricator (i.e.: Elliott catalog number 901717P – sold separately), must be installed in the air line that supplies this machine. The filter-lubricator should be adjusted to feed one drop of oil for every 50-75 cubic feet per minute (1,416 – 1,982 Liters per minute) of air going through the machine. Lubrication is necessary for all internal moving parts and rust prevention. The recommended lubricant to be used is a detergent, SAE #10 automotive engine oil.

Excessive moisture in the air line can cause rust formation in the motor and might also cause ice to form in the muffler due to expansion of air through the motor. The moisture problem can be corrected by installing a moisture separator in the air supply line.



WARNING

To prevent explosive hazard DO NOT supply this machine with combustible gases. Injury and/or property damage will result.



WARNING

DO NOT USE KEROSENE OR OTHER COMBUSTIBLE SOLVENTS.



WARNING

Eye protection is required. Keep face away from the exhaust ports and DO NOT flush unit with flammable solvent. Foreign material exiting the machine can be hazardous.

MAINTENANCE



WARNING

To reduce the risk of injury, always disconnect the air supply to the machine before performing any maintenance. Contact Elliott for all repairs.

Keep your Roto-Jet™ in good repair by adopting a regular maintenance program. Before each use, examine the general condition of your machine. Inspect connections, foot switch, air line and water hose for damage. Check for loose screws, misalignment, binding of moving parts, improper mounting, split flexshaft casing, broken parts or any other condition that may affect its safe operation. If abnormal noise or vibration occurs, turn the machine off immediately and have the problem corrected before further use. For more information see “Trouble Shooting” section. **DO NOT USE A DAMAGED MACHINE.** Tag damaged machines “DO NOT USE” until repaired.

Inspect the in-line filter-lubricator before each machine use. Be sure that the filter-lubricator is filled with the proper lubricant and the drip rate is set correctly. Recommended lubricant is detergent SAE #10 automotive engine oil, and the lubricator should be set for one drop for every 50 to 75 C.F.M. (1,416 – 1,982 liters per minute) consumed.

Should the motor become sluggish or inefficient it may become necessary to “flush” the motor with a cleaning agent to remove the contaminants.

To flush the motor:

- Move the throttle valve to the off position, disconnect the air supply, water supply and the flexshaft from the machine.
- Take the cover off the machine by removing the sheet metal screws that secure it to the base.
- Disconnect the air line and muffler from the air motor and add several teaspoons of solvent directly into the motor intake and exhaust ports.
- Rotate the shaft of the motor by hand, in both directions, for a few minutes.
- In a well ventilated area, reconnect the air supply line to the motor and to the machine, depress the foot switch, then slowly apply pressure using the throttle valve.
- Continue to run the motor until no trace of solvent is seen in the exhaust air.
- Move the throttle valve back to the off position and remove the air supply to the machine and to the motor.
- Lubricate the motor with a squirt of oil in the intake and exhaust chamber.
- Rotate the motor by hand, in both directions, and replace the air supply line and exhaust muffler to the motor.

- Replace the machine cover and test for proper assembly.
- If the machine is still sluggish and inefficient call an Elliott service facility.
- Recommended solvents for flushing are:
DEM-Kote 2X726
Loctite Safety Solvent
Inhibisol Safety Solvent

The vanes in the air motor are designed to give between 5,000 and 15,000 hours of operation under normal conditions and with the proper lubrication. If you suspect that the machine is in need of new vanes contact the Elliott service location. (Repair kit 04230 is available.)

Under normal conditions other lubrication of the machine between uses is not necessary, unless the machine has been operated “Dry”. Should you wish to use the Roto-Jet™ dry, the manifold drive shaft must be lubricated with a few drops of oil. Position the machine vertically, taking care not to damage the throttle valve or air supply coupling. Use a standard long spout oil can to place oil behind the brass square drive coupling. Using the machine dry after it has been used for wet operation, could damage the seals and bearings, which may require replacement if not lubricated.

Clean dust and debris from vents. Keep the machine handles clean, dry and free of oil or grease. Your machine has been finished with a two-part, epoxy, paint coating that is very durable and should last the life of the machine. Use only mild soap and a damp cloth to clean your machine. Certain cleaning solvents can be harmful to the painted surfaces. Never use flammable or combustible solvents around machines.

After each use, drain all water from the flexshaft outer casing. Store the flexshaft by laying it down, in a large diameter coil, in a dry, secured area.

After every cleaning season or 12 months remove the machine cover and check the motor coupling set screws for proper tightness. Inspect the coupling for alignment and verify the connections of the tubing within the machine. Replace the cover and position the machine vertically. Lubricate the manifold drive shaft, behind the female brass square drive coupling with a few drops of oil. An oil can with a standard long spout will be required. Make sure the flexshaft casing is drained of all water. Lubricate the flexshaft with a water soluble lubricant solution diluted to the manufacturers recommendations. An oil can with a standard long spout will be required. Position the spout between the flexshaft core and the casing. Fill and drain the flexshaft from both ends. When finished, store the flexshaft by laying it down, in a large diameter coil, in a dry, secured area. Start the next cleaning season by operating the machine prior to starting a new job. For more information on proper operation see “Operation” section.

TECHNICAL DATA

Horsepower: 4 H. P. @ 100 P.S.I. (6.89 Bar-Metric) Rotary, 4 Vane, Air Motor

RPM: Variable 0 to 2500

Air Consumption: @ 100 P.S.I. (6.89 Bar-Metric) 138 CFM (3,908 Liters per minute) No Load.

Torque: @ 100 P.S.I. (6.89 Bar-Metric) 350 RPM, 118 Inch Pounds Of Torque (13.3 Newton-Meters).

Overall Size: 21.5" x 10.25" x 10.5" (546 x 260 x 267 mm)

Machine Weight: 48 Pounds (21.77 KG)

The charts below refer to the flexshafts only. Match the prefix numbers to your shafting size. (See Fig. 3 and 4)

Wet Shafts (Fig.3)		
Prefix Flexshaft Number	Maximum Torque	
	(Inch Pounds)	(Newton-Meters)
0511*(xx)	16	1.8
0512*(xx)	105	11.9
0513*(xx)	210	23.7
0514A*(xx)	295	33.3
0514*(xx)	580	65.5
0515*(xx)	1155	130.5

*Length of shaft in feet completes the part number.
(Available in standard lengths of 16', 25', 33', and 49'. Consult factory for additional lengths.)

Dry Shafts (Fig.4)		
Prefix Flexshaft Number	Maximum Torque	
	(Inch Pounds)	(Newton-Meters)
0534*(xx)	580	65.5

*Length of shaft in feet completes the part number.
(Available in standard lengths of 25', 35', and 50'. Consult factory for additional lengths.)

When the flexshaft is used in a bend or radius configuration, the maximum torque capability of the core is reduced. The following charts demonstrate the effect that bending has on the flexshaft. (See Fig. 5, 6, 7, and 8)

Wet Shafts (Fig.5)								
Flexshaft Prefix No.	Radius 4"	Radius 6"	Radius 8"	Radius 10"	Radius 12"	Radius 15"	Radius 20"	Radius 25"
0511*(xx)	2	3	3	4	4	4	4	4
0512*(xx)	11	14	17	20	22	23	25	26
0513*(xx)	21	25	34	39	42	45	48	52
0514A*(xx)	25	36	47	55	57	59	68	74
0514*(xx)	N/A	53	74	95	107	119	131	140
0515*(xx)	N/A	N/A	105	139	168	200	221	242

Above figures represent Inch Pounds of Torque to Flexshaft Fatigue.

Wet Shafts (Fig.6)								
Flexshaft Prefix No.	Radius 102mm	Radius 152mm	Radius 203mm	Radius 254mm	Radius 305mm	Radius 381mm	Radius 508mm	Radius 635mm
0511*(xx)	0.2	0.3	0.3	0.5	0.5	0.5	0.5	0.5
0512*(xx)	1.2	1.6	1.9	2.3	2.5	2.6	2.8	2.9
0513*(xx)	2.4	2.8	3.8	4.4	4.7	5.1	5.4	5.9
0514A*(xx)	2.8	4.1	5.3	6.2	6.4	6.7	7.7	8.4
0514*(xx)	N/A	6.0	8.4	10.7	12.1	13.4	14.8	15.8
0515*(xx)	N/A	N/A	11.9	15.7	19.0	22.6	25.0	27.3

Above figures represent Newton-Meters of Torque to Flexshaft Fatigue.

*Length of shaft in feet completes the part number.

(Available in standard lengths of 16', 25', 33', and 49'. Consult factory for additional lengths.)

Dry Shafts (Fig.7)								
Flexshaft Prefix No.	Radius 4"	Radius 6"	Radius 8"	Radius 10"	Radius 12"	Radius 15"	Radius 20"	Radius 25"
0534*(xx)	N/A	N/A	N/A	95	107	119	131	140

Above figures represent Inch Pounds of Torque to Flexshaft Fatigue.

Dry Shafts (Fig.8)								
Flexshaft Prefix No.	Radius 102mm	Radius 152mm	Radius 203mm	Radius 254mm	Radius 305mm	Radius 381mm	Radius 508mm	Radius 635mm
0534*(xx)	N/A	N/A	N/A	10.7	12.1	13.4	14.8	15.8

Above figures represent Newton-Meters of Torque to Flexshaft Fatigue.

*Length of shaft in feet completes the part number.

(Available in standard lengths of 25', 35', and 50'. Consult factory for additional lengths.)

TROUBLE SHOOTING GUIDE

Machine will not start when foot switch is depressed.

- Check the throttle valve, be sure to adjust the valve to the proper speed for the cleaning device and the flexshaft size.
- Check the air supply connection and the quick disconnect hose coupling.
- Verify air supply connection to main piping is on.
- Check the foot switch hose for kinks or pinch points.

Machine starts but loses power and/or speed.

- Check for dirt or blockage in the air supply lines.
- Check for the proper lubrication flow to the machine from the lubricator.
- Verify the air supply has sufficient CFM (Liters per minute) to sustain the unit at speed. For more information see “Air Supply” section.
- If the machine has been in service for many hours, or has been supplied with dirty air, the motor may require a “Flush” operation. See “Maintenance” section.
- New vanes may be required if the machine has been in service longer than 5,000 hours. (Service Repair Kit 04230 is available.)
- Remove machine cover and check the muffler for corrosion or restrictions.

Machine rotates but no water is flowing from the end of the flexshafting.

- Check the flexshaft and machine connection.
- Check the garden hose entering the machine for kinks or pinch points.
- Check the water supply valve to verify that it is “on” and that water pressure is sufficient.

Water is leaking from the machine.

- Check O-ring (part #P8309-25) in the Manifold Assembly (part #04213). Replace if missing or worn.
- Remove the machine cover and verify that the tube from the water supply to the manifold is in place.
- Seals within the manifold are damaged or worn. Replace with Manifold Assembly 04213 or call an Elliott service facility.

Flexshaft stops rotating.

- Remove flexshaft from the machine and check the break-away coupling.
- Check the connection of the flexshaft and the machine, be sure flexshaft manifold cap is secured on manifold.
- Remove the machine cover and check the coupling between the motor and the manifold for proper alignment and tightness of the set screws.

Flexshaft breakage near the machine.

- Radius of flexshaft is too sharp. Position machine horizontally and at right angle to the tubes being cleaned. (See “Operation” section)
- Flexshaft is too short for the length of tube being cleaned causing too sharp a radius for proper operation of the flexshaft. Call Elliott to obtain the proper length

Flexshaft breakage near the cleaning device.

- Flexshaft is allowed to exit the far end of the tube being cleaned causing “Whipping” of the flexshaft. Measure and mark flexshaft casing with tape to prevent “over-travel” of flexshafting when cleaning. (See “Operation” section)
- Flexshaft is being forced through a tube blockage. Reduce the rate of feed on the flexshaft and allow cleaning device additional time to clear the blockage. (See “Operation” section)

Flexshaft coils up when cleaning device is inserted into the tube.

- Check the internal diameter of the tube (Elliott Tube Gauge is recommended) past the expanded portion at the tube opening. Verify the working diameter of the cleaning device being used.
- Reduce the feed rate of the flexshaft and allow more time for the cleaning device to remove deposits.
- Check for internal enhanced (rifled) surface under the deposit layer. Some cleaning devices are not designed to clean this type of surface.
- Check for sharp bends or pinch points in the flexshaft.
- Check for proper water flow through the flexshaft. (See “Operation” section)

How to repair broken flexshafts.

- See pages 22 & 23 for use of W900-00.

NOTES

Parts List

Item	Description	Part Number	Qty.
	Air Driven Rotary Unit	0420	
1	Air Motor w/ Muffler	04201	1
2	Shaft Coupling	04202	1
3	Male Disconnect	04204	1
4	Barbed Hose Connection	04205	1
5	Street Tee	04229	1
6	1/2 Male Elbow 90° Swivel	04208	4
7	Male Tube Connector	04209	1
8	Enclosure, Bottom	04210	1
9	Enclosure, Top	04211	1
10	Flow Valve	04212	1
11	Manifold Assembly	04213	1
12	Anchor Coupling	04222	1
13	1/2 Air Line Tubing - 10" Long	04215-10	1
14	1/2 Air Line Tubing - 12" Long	04215-12	1
15	Shaft Drive w/ Socket	04220	1
16	Air Valve	04224	1
17	1/4 Tee Swivel	04227	1
18	Half Grommet	04121	1
19	Solenoid Valve	04123	1
20	1/8 Male Elbow Swivel	04128	1
21	1/4 Male Elbow Swivel	04129	1
22	3/8 Tubing - 15" Long	04131-15	1
23	Connector	04132	1
24	Foot Valve Complete	04134	1
25	1/4 Tubing - 6" Long	04135-6	1
26	Swivel Connector	07107	1
27	Hex. Nipple Reducer	07108	1
28	Anchor Connector	07109	1
29	3/8 Male Elbow Swivel	06209	1
30	Lock Nut	07112	2
31	Support Pad	07125	4
32	Rubber Washer	07135	1
33	Elastic Lock Nut	546C	4
34	90 Street Elbow	514-8	1
35	Filister Head Machine Screw	544A	4
36	Elastic Lock Nut	546A	4
37	Bushing	04223	1
38	Self-Tapping Fil. Head Machine Screw	577-1	12
39	Hex. Head Cap Screw	130BB	4
40	Hex. Soc. Head Cap Screw	P8302-119	2
41	O-Ring	P8309-25	1
42	Name Plate	04225	1
43	Self-Locking Set Screws	548B	2
44	Male Elbow	04228	1
45	Washer	169T	4

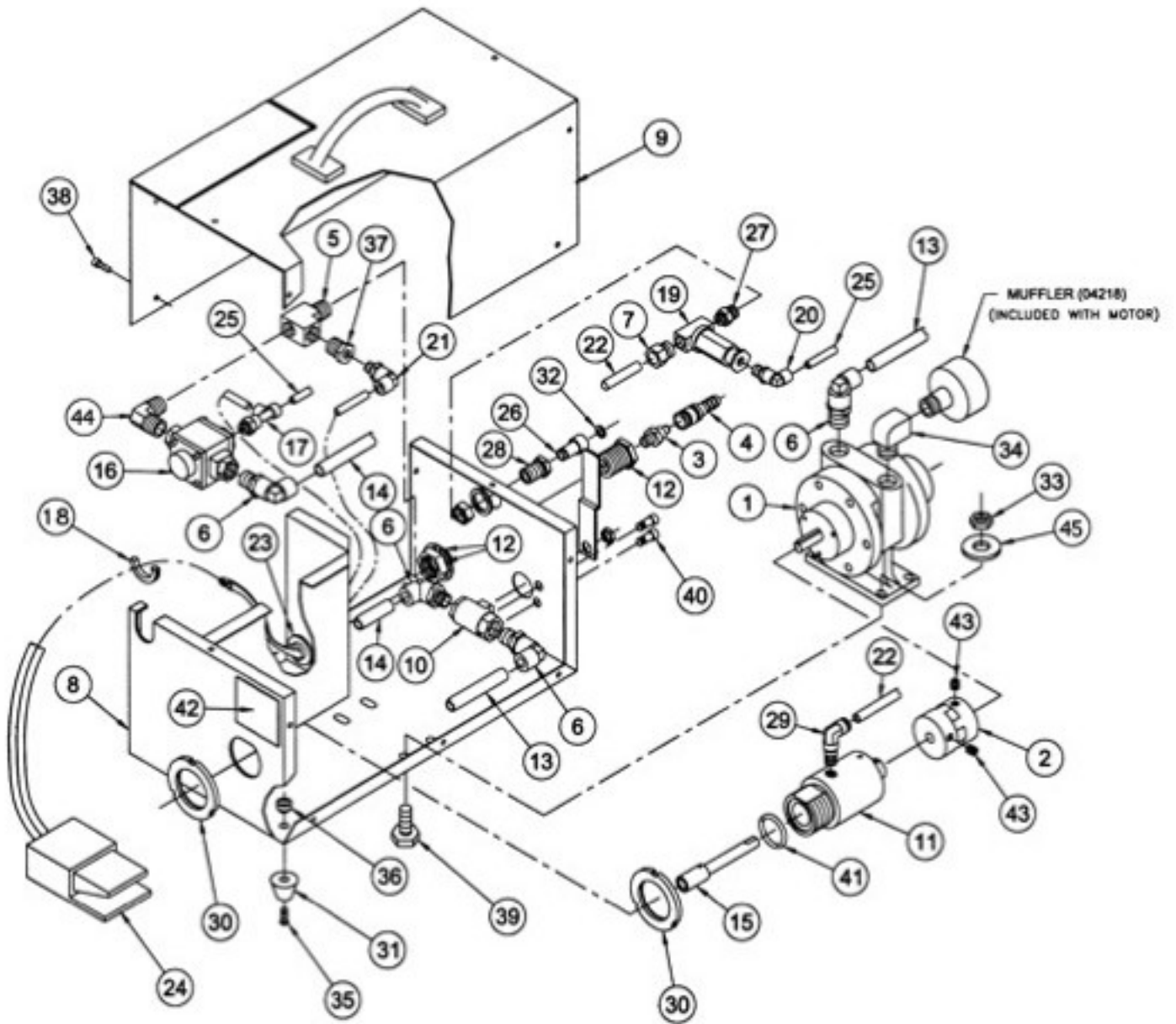

FLEXSHAFT REPAIR

Flexshaft Repair Instructions Instructions for Both the Tool and Motor Couplings Using the Elliott Crimping Block Assembly Part Number W900-00

1. Cut the outer casing back approximately 1" (25.4mm) for clearance to allow the core to be cleaned up at the break. Grind the end of the core taking care not to overheat the wire strands. Using a hacksaw to square the broken end will cause the wire strands to flex and unwind.
Note: The compression fitting on the motor coupling should not be removed from the casing, if the excess length of casing is trimmed from the tool coupling end of the flexshaft.
2. Slightly bevel the circumference of the core to remove any burrs.
3. Insert the replacement coupling onto the core. Be sure the core is fully engaged to the full drilled length of the coupling.
Note: When replacing the motor coupling, insure that the square washer has been placed onto the core before inserting the motor coupling.
4. Locate the assembly of the core and coupling in the proper hole location of the crimping block. Position the assembly in the crimping block with the core end of the coupling, flush with the side of the block.
5. Insert the drive pin in the proper hole above the coupling to be crimped.
6. Strike the pin with a hammer. Care must be taken with this operation, excessive force will deform the coupling and cause the core to distort and unwind.
7. For flexshaft sizes 0513, 0514 and 0515, rotate the coupling in the crimping block approximately 60° and strike the pin again. Repeat this operation around the coupling. For flexshaft sizes 0511 and 0512, rotate the coupling in the crimping block approximately 120° and strike the pin again. Repeat this operation around the coupling.
8. The coupling is now secure with equally spaced crimping locations holding the core.

Crimp locations
0511 0512
@ 120° intervals

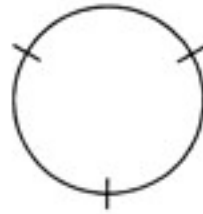

Crimp locations
0513 0514 0515
@ 60° intervals

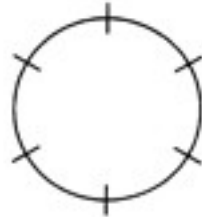

W900-00

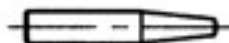
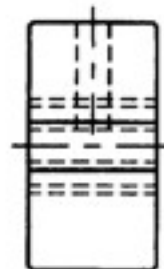
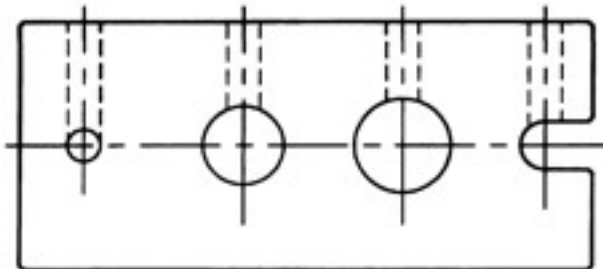





Contact Us

Elliott Tool offers a complete line of precision tube tools to meet your needs. Contact us or your local support.

Elliott Tool Technologies, Ltd.
1760 Tuttle Avenue
Dayton, Ohio 45403-3428
Phone: +1 937 253 6133 • +1 800 332 0447
Fax: +1 937 253 9189
www.elliott-tool.com

Locally Supported By:

www.elliott-tool.com/support